

allPIXA pro 7K & 6000px

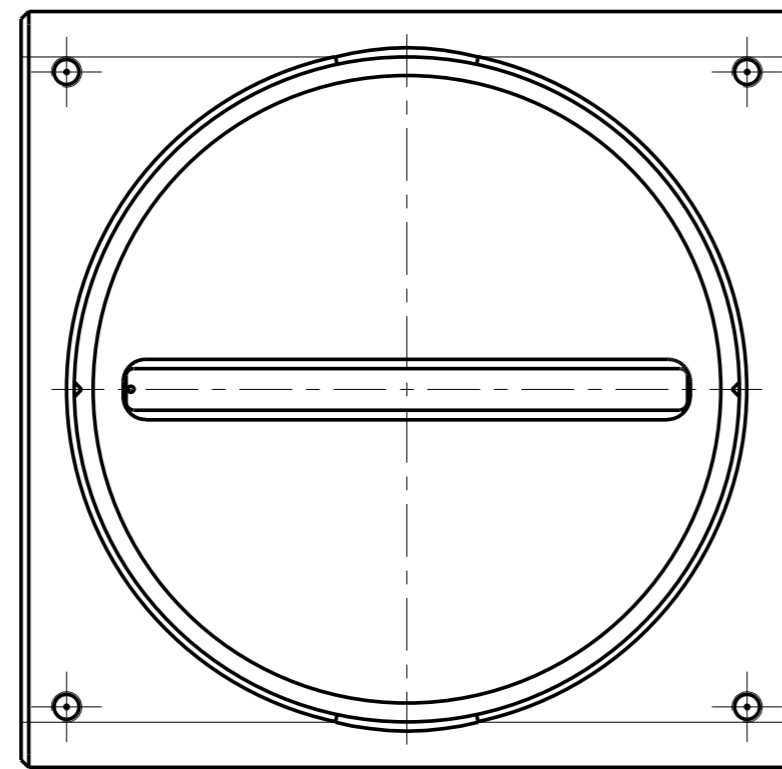

4:5 **allPIXA pro 7K & 6000px**

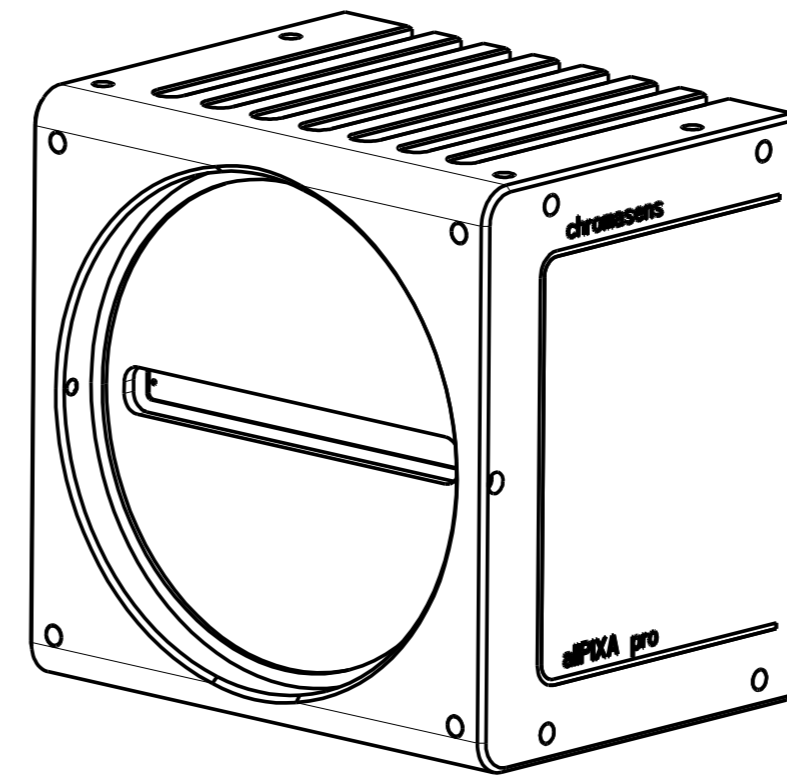

4:5 **allPIXA pro 2K & 4K**

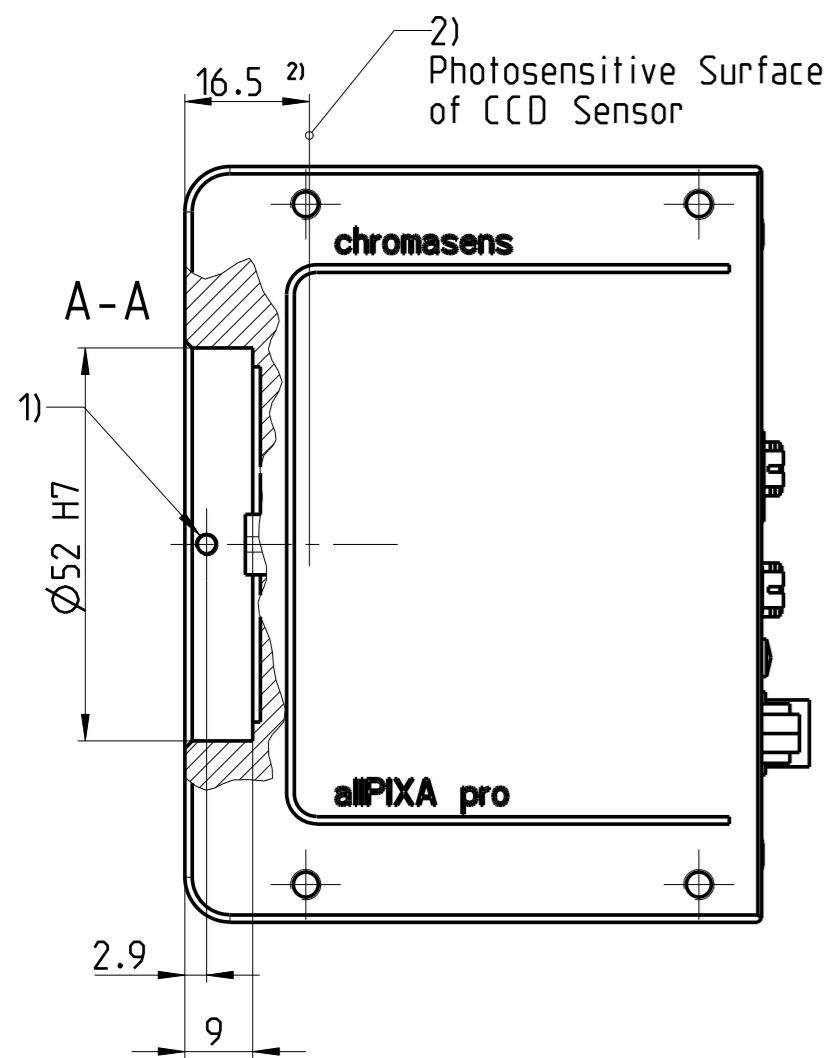
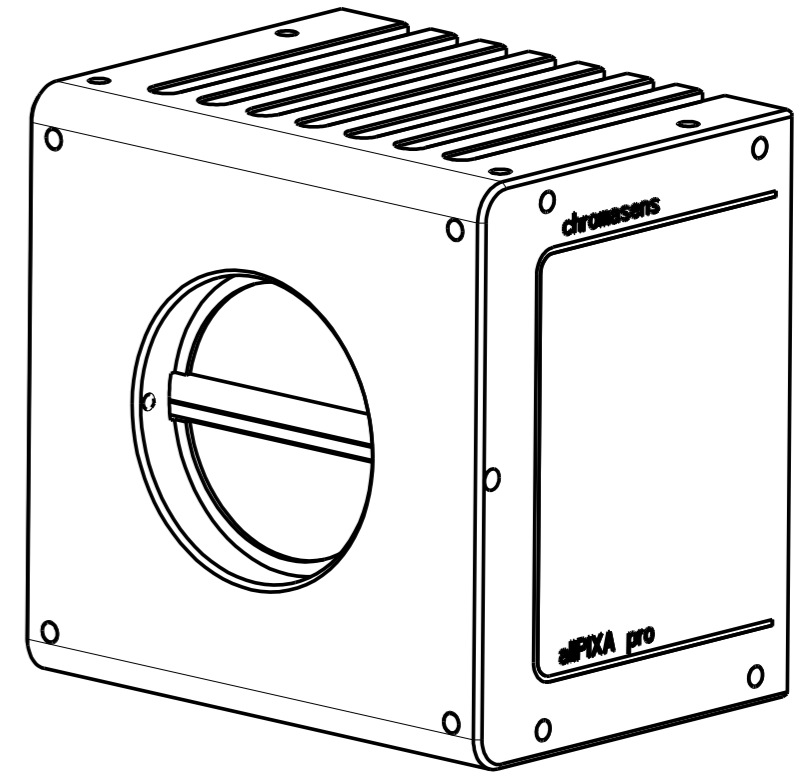

allPIXA pro 2K & 4K

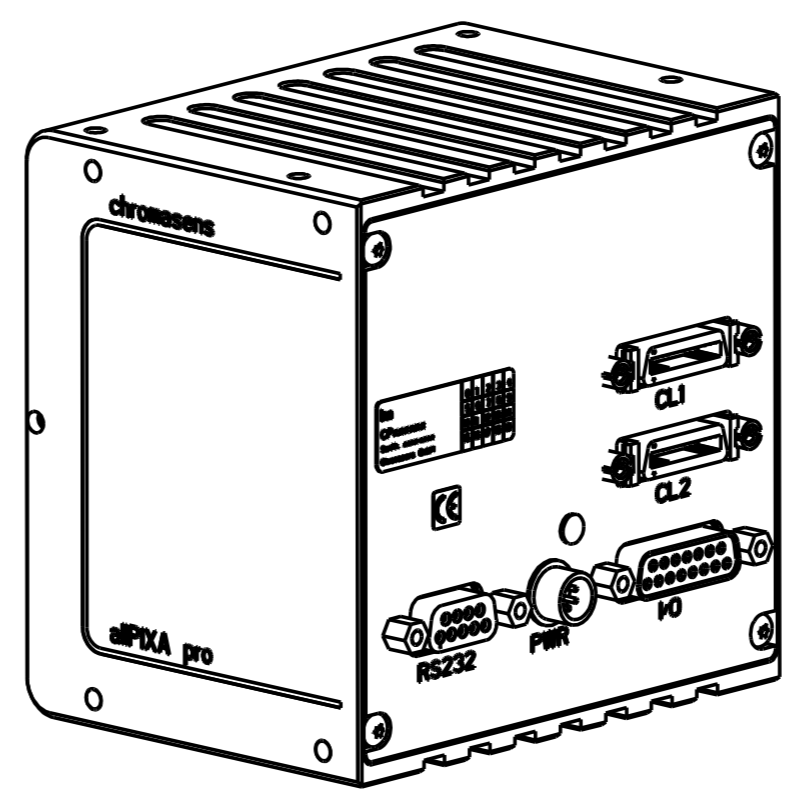
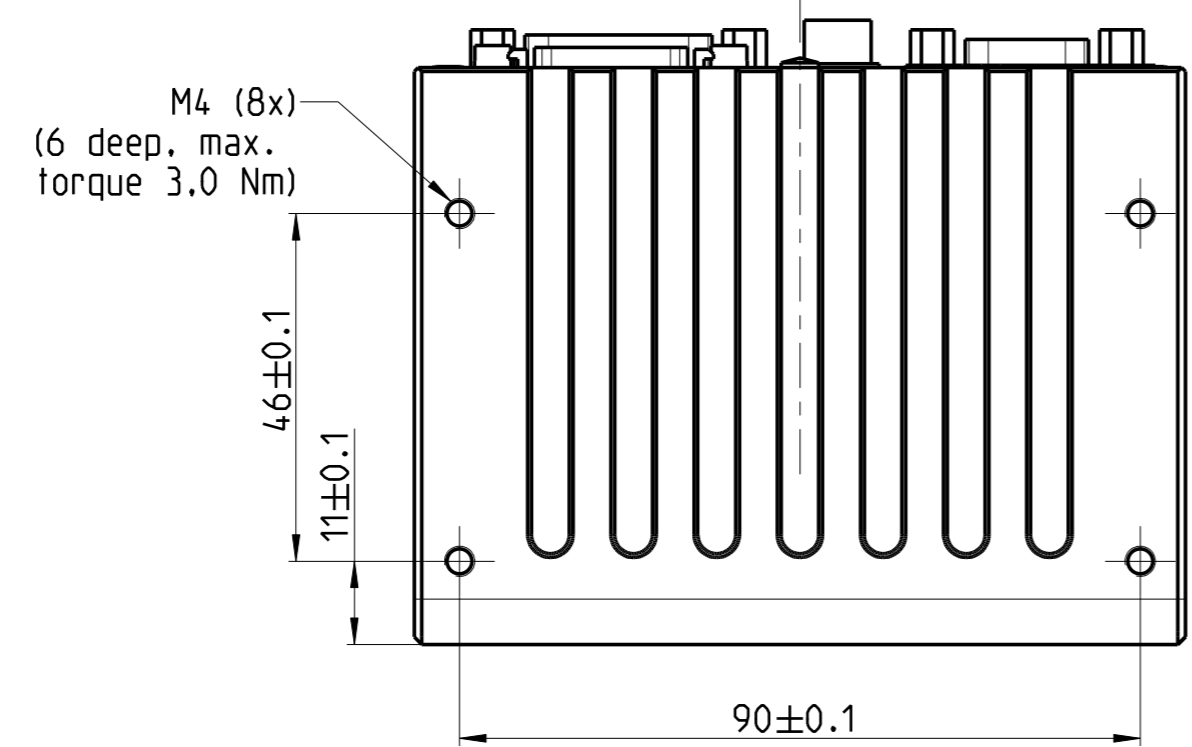
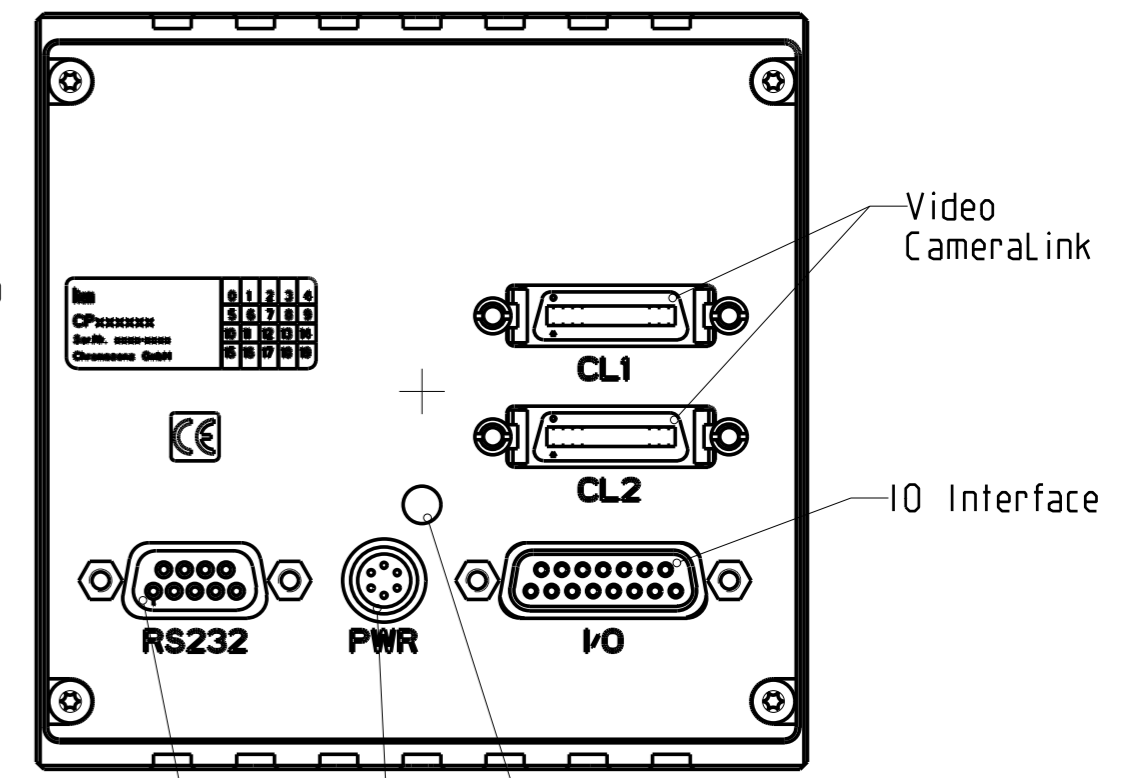
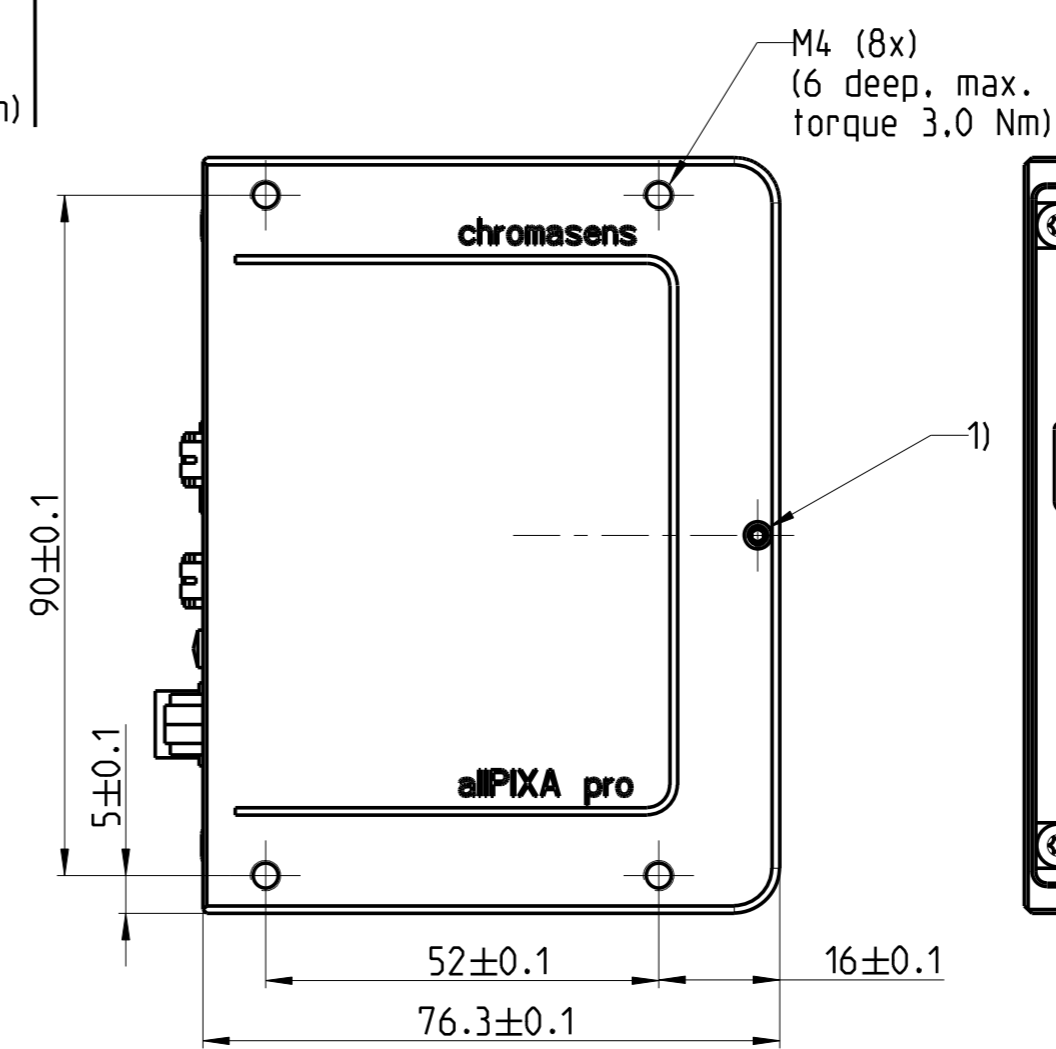
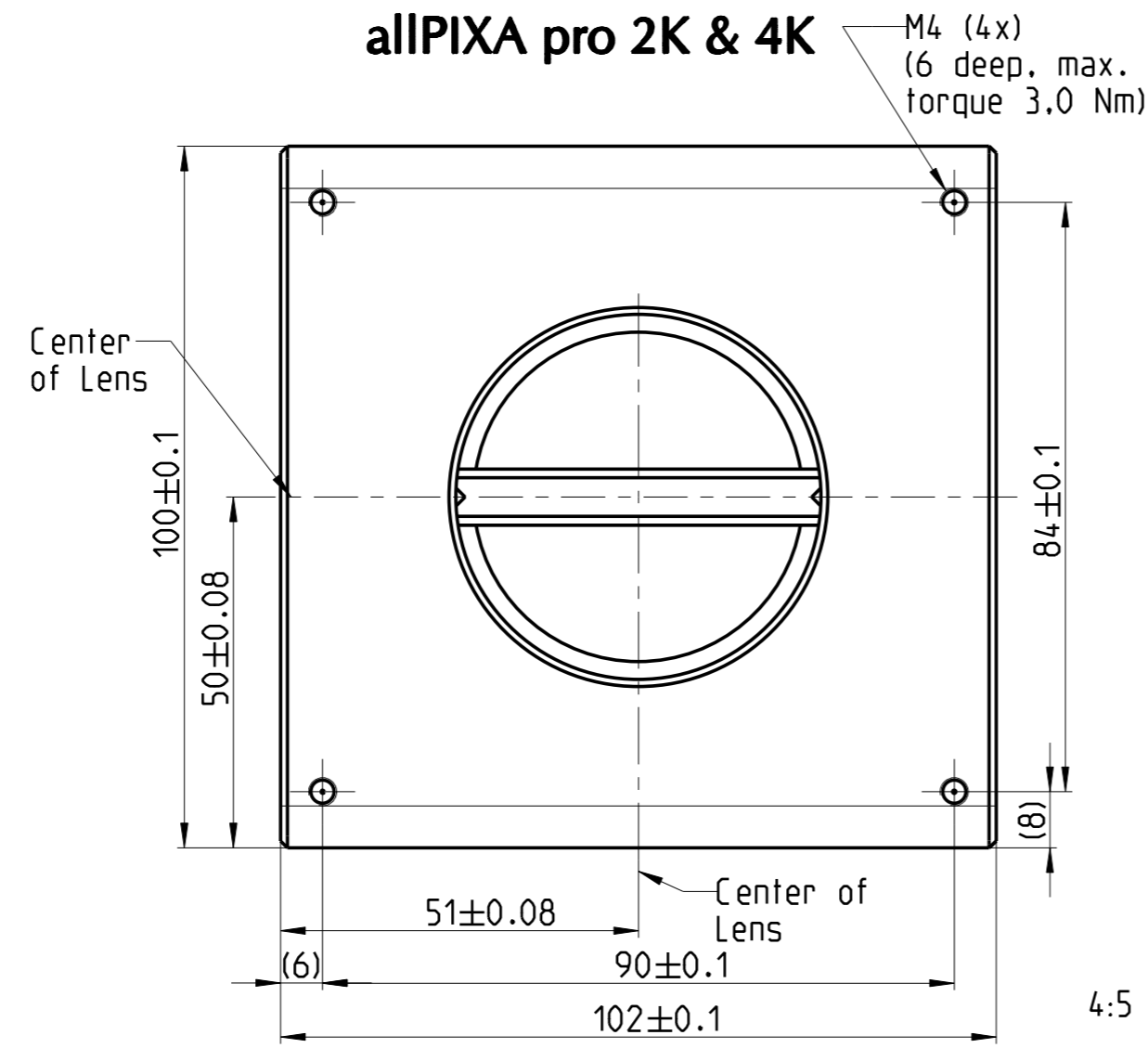

- 1) Clamping screw for lens adapter fitting: hexagon socket set screw DIN914 / ISO4027 (M3x6) Use allen key size 1.5mm, max. torque 30Ncm.
- 2) Photosensitive Surface of CCD Sensor: 16.5 mm (optical, with front glass elongation), 16.26 mm (mechanical), see Note III of chapter 3.3 in Manual. Tolerances according Manual

CONFIADO COMO SECRETO INDUSTRIAL . NOS RESERVAMOS TODOS LOS DERECHOS PROPRIETARY DATA . COMPANY CONFIDENTIAL . ALL RIGHTS RESERVED Weitergabe sowie Vervielfältigung dieser Unterlage , Verwertung und Mitteilung ihres Inhalts nicht gestattet , soweit nicht ausdrücklich zugestanden . Zuwiderhandlungen verpflichten zu Schadensersatz . Alle Rechte vorbehalten , insbesondere fuer den Fall der Patenterteilung oder GM-Eintragung .

ISO 128	Tot ISO 8015 DIN 2768 - mH	ISO 1302	Massstab 1:1
Datum: 28.02.2014		Name: Sulger	
Zust: Mitteilung		Gepr.: -	
1	19.02.2015	Sulger	Chromosens GmbH Max-Strasse 116 82074 München
allPIXA pro			Blatt 1 -
CM060-B402-VOX-C			