



GIGE VISION CAMERAS

# Alvium G1 User Guide

V1.4.0

FW 00.12.00.00611a22

Note: Lenses are not part of this product.

**Quick links**

- [This document at a glance](#) on page 8
- [Contact us](#) on page 14
- [Contents](#) on page 15

# Read before use

## EN - English

### Safety

Before using the product, read these safety instructions. Observe the warnings at all times. Use the camera only as stated in the [Intended use](#) on page 34.

**CAUTION****Risk of burns**

A camera in operation can reach temperature levels which could cause burns.

**CAUTION****Injury by falling cameras or lenses**

A falling camera or lens can cause injury.

**CAUTION****Risk of cuts by sharp edges of lens mounts**

The threads of the lens mount can have sharp edges.

### Intended use

Intended use of Allied Vision product is the integration into vision systems by professionals. All Allied Vision product is sold in a B2B setting.

## DA - Dansk

### Sikkerhed

Læs sikkerhedsanvisningerne, før kameraet bruges. Overhold alle advarsler. Brug kun kameraet som anført i [Intended use](#) på side 34.



#### **FORSIGTIG**

##### **Forbrændingsfare**

Når kameraet bruges, kan det blive meget varmt og forårsage forbrændinger.



#### **FORSIGTIG**

##### **Kvæstelser, hvis kameraet eller linser falder ned**

Falder kameraet eller linsen ned, kan dette forårsage kvæstelser.



#### **FORSIGTIG**

##### **Fare for snitsår på linsemodulets skarpe kanter**

Linsemodulets gevind kan have skarpe kanter.

### Tilsluttet brug

Allied Vision produktets tilsluttede brug er en indbygning i et visionssystem, udført af fagfolk. Alle Allied Vision produkter sælges i B2B.

## DE - Deutsch

### Sicherheit

Bevor Sie die Kamera benutzen, lesen Sie diese Sicherheitshinweise. Beachten Sie diese Hinweise immer. Verwenden Sie die Kamera nur wie beschrieben in [Intended use](#) auf Seite 34.



#### VORSICHT

##### **Gefahr von Verbrennungen**

Im Betrieb kann die Kamera Temperaturen erreichen, die zu Verbrennungen führen.



#### VORSICHT

##### **Verletzung durch fallende Kameras oder Objektive**

Eine fallende Kamera oder ein fallendes Objektiv kann Verletzungen verursachen.



#### VORSICHT

##### **Schnitte durch scharfkantige Objektivgewinde**

Objektivgewinde können scharfe Kanten haben.

### Bestimmungsgemäßer Gebrauch

Allied Vision Produkte sind bestimmt für die Integration in Bildverarbeitungssysteme durch Fachpersonal. Alle Allied Vision Produkte werden in einer B2B-Umgebung verkauft.

## ES - Español

### Seguridad

Antes de utilizar la cámara lea estas instrucciones de seguridad. Observe las advertencias en todo momento. Utilice la cámara solo tal y como se estipula en el [Intended use](#) en la página 34.



#### ATENCIÓN

##### **Riesgo de quemaduras**

Una cámara en funcionamiento puede alcanzar temperaturas que podrían provocar quemaduras.



#### ATENCIÓN

##### **Lesiones en caso de que las cámaras o las lentes se caigan**

Si una cámara o una lente se cae puede provocar lesiones.



#### ATENCIÓN

##### **Riesgo de cortes debido a los bordes afilados del objetivo**

Las roscas de los objetivos pueden tener bordes afilados.

### Uso previsto

El uso previsto del producto Allied Vision es la integración en el sistema de visión por parte de profesionales. Todos los productos Allied Vision se venden dentro de una relación B2B.

## FI - Suomi

### Turvallisuus

Lue nämä turvallisuusohjeet ennen kameran käyttöä. Noudata varoituksia joka hetki. Käytä kameraa ainoastaan kohdassa [Intended use](#) sivulla 34 kuvatulla tavalla.



#### HUOMIO

##### **Palovammojen vaara**

Käytössä olevan kameran saavuttamat lämpötilatasot voivat aiheuttaa palovammoja.



#### HUOMIO

##### **Putoavien kameroiden tai linssien aiheuttamat vammat**

Putoava kamera tai linssi voi aiheuttaa vammoja.



#### HUOMIO

##### **Linssien kiinnikkeiden terävien reunojen aiheuttamien viiltovammojen vaara**

Linssin kiinnikkeiden kierteiden reunat voivat olla teräviä.

### Käyttötarkoitus

Allied Vision-tuotteen käyttötarkoitus on integrointi kuvajärjestelmiin ammattilaisten toimesta. Kaikki Allied Vision-tuotteet myydään B2B-ympäristössä.

## FR - Français

### Sécurité

Veillez lire ces consignes de sécurité avant d'utiliser la caméra. Respectez continuellement les avertissements. Utilisez la caméra uniquement comme indiqué sous [Intended use](#), page 34.



#### ATTENTION

##### Risque de brûlures

Une caméra en service peut atteindre des niveaux de température susceptibles d'entraîner des brûlures.



#### ATTENTION

##### Blessures en cas de chute de caméras ou d'objectifs

La chute d'une caméra ou d'un objectif peut entraîner des blessures.



#### ATTENTION

##### Risque de coupures sur les bords tranchants des montures d'objectif

Les filetages des montures d'objectif peuvent présenter des bords tranchants.

### Utilisation prévue

L'utilisation prévue du produit Allied Vision est son intégration dans des systèmes de vision par le soin de professionnels. Tout produit Allied Vision est vendu dans un cadre B2B.

## עברית - HE

### בטיחות

לפני השימוש במצלמה, עליך לקרוא את הוראות הביטחון האלו. עליך לממש הוראות ביטחון אלו תמיד. השימוש במצלמה הוא רק לפי מה שכתוב ב"כוונת השימוש" (Intended use) בעמוד 34.

#### זהירות

##### סכנת כווייה

בזמן הפערת המצלמה עלולות טמפרטורות גבוהות לעלות, שיכולות לגרום לכוויות.



#### זהירות

##### פגיעה מנפילת מצלמות או עדשות

מצלמה או עדשה שנופלות עלולות לגרום לפגיעה.



#### זהירות

##### סכנה להחתך מתברג חד של העדשה

תברג תושבת העדשה עלול להיות חד עד כדי פגיעה.



### שימוש מיועד

מוצרי AlliedVision מיועדים לשילוב במערכות ממוחשבת לעיבוד צילומים ע"י אנשי מקצוע. כל מוצרי AlliedVision נמכרים לשימוש בסביבת B2B.



## IT - Italiano

### Sicurezza

Leggere queste istruzioni per la sicurezza prima di utilizzare la telecamera. Osservare sempre tutte le avvertenze. Utilizzare la telecamera come descritto alla sezione [Intended use](#) a pagina 34.



#### ATTENZIONE

##### **Pericolo di ustioni**

Durante il funzionamento una telecamera può raggiungere temperature elevate che possono essere causa di ustioni.



#### ATTENZIONE

##### **Lesioni dovute alla caduta di telecamere o lenti**

La caduta di una telecamera o di una lente può causare delle lesioni.



#### ATTENZIONE

##### **Pericolo di tagliarsi sui bordi affilati degli attacchi della lente**

I bordi della filettatura dell'attacco della lente possono essere affilati.

### Uso previsto

Il prodotto Allied Vision è concepito per essere integrato in sistemi di monitoraggio in campo professionale. Tutti i prodotti Allied Vision sono venduti in uno scenario B2B.

## JA - 日本語

### 安全性

本カメラを使用する前に、この安全の手引きをお読みください。常に、警告事項を守ってください。必ず、[Intended use](#) 34 ページの通りに、本カメラを使用してください。



#### 注意

##### やけどの危険性

作動中のカメラは、やけどを引き起こす温度まで熱くなる恐れがあります。



#### 注意

##### カメラまたはレンズの落下によるけが

カメラまたはレンズが落下すると、けがをする恐れがあります。



#### 注意

##### レンズマウントの鋭利な端部で切り傷の危険性

レンズマウントのギザギザの部分が鋭利である可能性があります。

### 用途

Allied Vision製品は、専門家が視覚装置に統合することを意図したものです。すべてのAllied Vision製品は、企業間取り引き用に販売されています。

## NL - Nederlands

### Veiligheid

Lees deze veiligheidsinstructies voordat u de camera gaat gebruiken. Neem deze waarschuwingen altijd in acht. Gebruik de camera uitsluitend, zoals aangegeven in het [Intended use](#) op pagina 34.



#### VOORZICHTIG

##### Risico van verbranding

Een camera die gebruikt wordt, kan temperatuurwaarden bereiken die brandwonden kunnen veroorzaken.



#### VOORZICHTIG

##### Letsel door vallende camera's of lenzen

Een vallende camera of lens kan letsel veroorzaken.



#### VOORZICHTIG

##### Risico van snijwonden door scherpe randen van lensbevestigingen

Het schroefdraad van de lensbevestiging kan scherpe randen hebben.

### Beoogd gebruik

Het beoogde gebruik van het Allied Vision-product is de integratie in optische systemen door professionals. Alle Allied Vision-producten worden verkocht in de B2B-markt.

## NO - Norsk

### Sikkerhet

Les disse sikkerhetsinstruksene før du bruker kameraet. Følg advarslene til en hver tid. Bruk kun kameraet i samsvar med [Intended use](#) på side 34.



#### FORSIKTIG

##### Risiko for brannskader

Et kamera i bruk kan nå temperaturnivåer som kan forårsake brannskader.



#### FORSIKTIG

##### Skade ved fallende kameraer eller linser

Et fallende kamera eller en fallende linse kan forårsake skade.



#### FORSIKTIG

##### Risiko for kutt fra skarpe kanter på linsefester

Sporene på linsefestet kan ha skarpe kanter.

### Tiltenkt bruk

Den tiltenkte bruken av Allied Vision-produktet er integrering i visjonssystemer av profesjonelle. Alle Allied Vision-produkter selges i en forretning til forretning-situasjon.

## SV - Svenska

### Säkerhet

Läs igenom säkerhetsinstruktionerna innan du använder kameran. Var hela tiden särskilt uppmärksam på varningarna. Använd enbart kameran på det sätt som anges i [Intended use](#) på sida 34.



#### VARNING

##### Risk för brännskada

En kamera i drift kan komma upp i temperaturer som kan orsaka brännskador.



#### VARNING

##### Risk för skador från fallande kameror eller objektiv

Fallande kameror eller objektiv kan förorsaka skador.



#### VARNING

##### Risk för skärsår från vassa kanter på objektivfattningar

Objektivets gängor kan ha vassa kanter.

### Avsedd användning

Den avsedda användningen av Allied Vision-produkter är integrering i visionssystem av fackmän. Samtliga Allied Vision-produkter säljs i en B2B-miljö.

# ZH - 简体中文版

## 安全需知

使用本相机前，请阅读本安全说明书。请务必遵守相关警告和 [Intended use](#) 于第 34 页。



### 注意事项

#### 烫伤风险

相机操作过程中温度可能上升并导致烫伤风险。



### 注意事项

#### 相机或者镜头跌落造成伤害

相机或者镜头可能会跌落并造成伤害。



### 注意事项

#### 镜头接口的锐利边缘划伤风险

镜头接口螺纹边缘可能较为锐利。

## 预期用途

Allied Vision 产品的预期用途是由专业人士整合到视觉系统中。所有 Allied Vision 的产品均通过 B2B 渠道销售。

# This document at a glance



Get an overview of Alvium G1 documentation:

Consider for Alvium G1 cameras .....	16
Shipping contents.....	16
What else do you need? .....	16

## Consider for Alvium G1 cameras

For a smooth product experience, we suggest you to:

- Build up general knowledge: [Tips and tricks to connect 1000BASE-T](#) on page 167.
- Set up a quick running test: [Installing the camera](#) on page 132.
- Find solutions for issues: [Troubleshooting common issues](#) on page 182.

## Shipping contents

- Alvium G1 camera
- Download Instructions for First Camera Operation document

## What else do you need?

This is a selection of helpful downloads:

Download	Link
Alvium Cameras Features Reference	<a href="http://www.alliedvision.com/en/support/technical-documentation/alvium-gige-documentation">www.alliedvision.com/en/support/technical-documentation/alvium-gige-documentation</a>
Application notes	
<b>Vimba X SDK</b> for Windows, Linux, and Linux/ARM, including <b>Vimba X Viewer</b> , <b>Driver Installer</b> , and <b>Firmware Updater</b>	<a href="http://www.alliedvision.com/en/products/software/vimba-x-sdk">www.alliedvision.com/en/products/software/vimba-x-sdk</a>
<b>Firmware</b> downloads	<a href="http://www.alliedvision.com/en/support/firmware-downloads">www.alliedvision.com/en/support/firmware-downloads</a>
STEP files	Find downloads for your Alvium model at <a href="http://www.alliedvision.com/en/camera-selector">www.alliedvision.com/en/camera-selector</a>
<b>Accessories</b> , such as interface cables and cards, power and I/O cables, power supplies, lenses, and tripod and mounting adapters	<a href="http://www.alliedvision.com/en/products/accessories">www.alliedvision.com/en/products/accessories</a>

Table 1: Downloads for Alvium G1 cameras



# Contact us

## Website, email

### General

[www.alliedvision.com/en/contact](http://www.alliedvision.com/en/contact)  
[info@alliedvision.com](mailto:info@alliedvision.com)

### Distribution partners

[www.alliedvision.com/en/avt-locations/avt-distributors](http://www.alliedvision.com/en/avt-locations/avt-distributors)

### Support

[www.alliedvision.com/en/support](http://www.alliedvision.com/en/support)  
[www.alliedvision.com/en/about-us/contact-us/technical-support-repair-/rma](http://www.alliedvision.com/en/about-us/contact-us/technical-support-repair-/rma)

## Offices

### Europe, Middle East, and Africa (Headquarters)

Allied Vision Technologies GmbH  
Taschenweg 2a  
07646 Stadtroda, Germany  
T// +49 36428 677-0 (Reception)  
T// +49 36428 677-230 (Sales)  
F// +49 36428 677-28

### Asia-Pacific

#### China

Allied Vision Technologies  
(Shanghai) Co., Ltd.  
2-2109 Hongwell Int. Plaza  
1602# ZhongShanXi Road  
Shanghai 200235, China  
T// +86 21 64861133

#### Singapore

Allied Vision Technologies Asia Pte. Ltd  
82 Playfair Rd, #07-01 D'Lithium  
Singapore 368001  
T// +65 6634 9027

### North, Central, and South America

#### Canada

Allied Vision Technologies Canada Inc.  
300 – 4621 Canada Way  
Burnaby, BC V5G 4X8, Canada  
T// +1 604 875 8855

#### USA

Allied Vision Technologies, Inc.  
102 Pickering Way- Suite 502  
Exton, PA 19341, USA  
Toll-free// +1-877-USA-1394  
T// +1 978 225 2030

# Contents

<b>Read before use</b>	<b>2</b>
EN - English	2
DA - Dansk	3
DE - Deutsch	4
ES - Español	5
FI - Suomi	6
FR - Français	7
HE - עברית	8
IT - Italiano	9
JA - 日本語	10
NL - Nederlands	11
NO - Norsk	12
SV - Svenska	13
ZH - 简体中文版	14
<b>This document at a glance</b>	<b>15</b>
Consider for Alvium G1 cameras	16
Shipping contents	16
What else do you need?	16
<b>Contact us</b>	<b>17</b>
<b>Document history and conventions</b>	<b>23</b>
Document history	24
Conventions used in this user guide	28
Typographic styles	28
Symbols and notes	29
Acronyms and terms	30
<b>Compliance, safety, and intended use</b>	<b>31</b>
Camera identification	32
Compliance notifications	32
For customers in the US	32
For customers in Canada	33
Pour utilisateurs au Canada	33
Avoid electromagnetic interferences	33
Intended use	34
Copyright and trademarks	34
Your safety	35
Camera mounting	36
Product safety	36
Electrical connections	36
Optical components	39
Mechanical components	40

<b>Specifications</b>	<b>41</b>
Applied standards	42
GenICam	42
IP class	42
Shock and vibration	42
Notes on specifications	45
Sensor	45
Exposure time and frame rates	46
Triggering and sensor shutter types	48
Digital binning	49
Sensor binning	49
Multiple regions	49
Operation for typical power consumption	50
Dimensions and mass	50
Alvium G1 model specifications	51
Alvium G1-030 VSWIR	51
Alvium G1-040m/c	54
Alvium G1-130 VSWIR	57
Alvium G1-158m/c	60
Alvium G1-234m/c	63
Alvium G1-240m/c	66
Alvium G1-319m/c	69
Alvium G1-500m/c	72
Alvium G1-507m/c	75
Alvium G1-510m/c	78
Alvium G1-811m/c	81
Alvium G1-812 UV	84
Alvium G1-1236m/c	87
Alvium G1-1240m/c	90
Alvium G1-1242m/c	93
Alvium G1-1620m/c	97
Alvium G1-2040m/c	100
Alvium G1-2050m/c	103
Alvium G1-2460m/c	106
White balance default	109
Dimensions and mass	110
Technical drawings	110
C-Mount	110
CS-Mount	111
S-Mount	112
Lens mounts and maximum protrusion	113
IR cut filter	114
Sensor position accuracy	115
Sensor shift and rotation	115
Sensor tilt	116
User sets	117
Supported features	117
Trigger features and UserSetDefault	117

Camera feature availability.....	118
<b>Lenses: Focal length vs. field of view</b>	<b>120</b>
About this chapter.....	121
Parameters in tables.....	121
Optical vignetting with certain lenses.....	121
About S-Mount lenses.....	122
Focal length versus field of view.....	122
Alvium G1-030 VSWIR.....	122
Alvium G1-040m/c.....	123
Alvium G1-130 VSWIR.....	123
Alvium G1-158m/c.....	124
Alvium G1-234m/c.....	124
Alvium G1-240m/c.....	125
Alvium G1-319m/c.....	125
Alvium G1-500m/c.....	126
Alvium G1-507m/c.....	126
Alvium G1-510m/c.....	127
Alvium G1-811m/c, G1-812 UV.....	127
Alvium G1-1236m/c.....	128
Alvium G1-1240m/c.....	128
Alvium G1-1242m/c.....	129
Alvium G1-1620m/c.....	129
Alvium G1-2040m/c.....	130
Alvium G1-2050m/c.....	130
Alvium G1-2460m/c.....	131
<b>Installing the camera</b>	<b>132</b>
Touching hot cameras.....	133
Usage of heat sinks.....	133
Mounting Alvium G1 cameras.....	134
Bottom or top mounting.....	134
Front mounting.....	135
Adapting maximum torque values.....	135
Mounting the lens.....	136
Mounting and focusing S-Mount lenses.....	137
Configuring the host computer.....	140
Installing the NIC driver.....	140
Modifying the NIC IP address.....	141
Adjusting the NIC driver settings.....	142
Connecting to the host computer.....	143
Allied Vision software.....	143
Third-party software.....	143
Powering up the camera.....	144
Powering the camera via I/O port.....	144
Powering the camera via PoE.....	144
<b>Camera interfaces</b>	<b>145</b>
I/Os: Precautions.....	146

Back panel . . . . .	147
I/O connector pin assignment . . . . .	148
I/Os and GPIOs . . . . .	149
Isolated input description . . . . .	149
I/O use for UART . . . . .	149
Isolated output description . . . . .	150
Non-isolated GPIOs description . . . . .	152
Status LEDs . . . . .	154
LED codes . . . . .	154
Error state . . . . .	154
<b>Triggering and timings</b>	<b>155</b>
Trigger signal flow . . . . .	156
Trigger latency . . . . .	156
Triggering with rolling shutter cameras . . . . .	157
Ignored triggers . . . . .	158
Trigger features and UserSetDefault . . . . .	158
<b>Image data flow</b>	<b>159</b>
<b>Firmware update</b>	<b>161</b>
Please note . . . . .	162
Firmware update with Vimba X . . . . .	162
Updating the firmware . . . . .	163
Error handling . . . . .	165
<b>Performance and troubleshooting</b>	<b>166</b>
Tips and tricks to connect 1000BASE-T . . . . .	167
Hardware selection . . . . .	167
NIC hardware installation . . . . .	168
NIC firmware and drivers . . . . .	168
NIC driver settings . . . . .	168
Operation system settings . . . . .	169
Vimba X TL settings . . . . .	170
Optimizing performance . . . . .	174
Image transfer with rolling shutter cameras . . . . .	174
Frame rate jitter . . . . .	174
Value changes by feature interdependencies . . . . .	175
Dark current compensation . . . . .	177
Shutter types affecting image readout . . . . .	178
Operating systems and bandwidth . . . . .	179
Reference system . . . . .	180
Feature values . . . . .	181
Troubleshooting common issues . . . . .	182
Camera is not powered . . . . .	182
Camera is not detected in the viewer . . . . .	182
Camera cannot acquire images . . . . .	183
Packets are dropped . . . . .	184

Index	185
-------	-----

# Document history and conventions



This chapter includes:

Document history .....	24
Conventions used in this user guide.....	28
Acronyms and terms .....	30

## Document history

Version	Date	Remarks
V1.4.0	2023-Jun-06	<p><b>Firmware version:</b> 00.12.00.00611a22</p> <ul style="list-style-type: none"> <li>Updated Hebrew contents in <a href="#">Read before use</a> on page 2.</li> <li>Updated contents in <a href="#">Operation for typical power consumption</a> on page 50.</li> <li>Updates data in <a href="#">Alvium G1 model specifications</a> on page 51:               <ul style="list-style-type: none"> <li>Added data on multiple regions and sensor binning for selected models.</li> <li>Changed minimum operating temperature value for Mainboard from +5 °C to -20 °C.</li> <li>Updated QE curves for G1-030 VSWIR and G1-130 VSWIR.</li> </ul> </li> <li>Updated maximum resolution values and the according frame rates for <a href="#">Alvium G1-1620m/c</a> on page 97 to 5328 (H) × 3040 (V).</li> <li>Reduced value for sensor shift with G1-2050 models to 150 μm in <a href="#">Sensor position accuracy</a> on page 115.</li> <li>Added multiple regions and sensor binning to <a href="#">Camera feature availability</a> on page 118.</li> <li>Corrected data in table for <a href="#">I/O use for UART</a> on page 149.</li> <li>Added multiple regions and sensor binning to <a href="#">Image data flow</a> on page 159.</li> <li>Updated contents in <a href="#">Firmware update</a> on page 161.</li> <li>Updated contents for Intel I219LM chipset in <a href="#">Hardware selection</a> on page 167.</li> <li>Updated contents for Vimba X.</li> <li>Applied editorial changes.</li> </ul>
V1.3.0	2023-Jan-09	<ul style="list-style-type: none"> <li>Added G1-030 VSWIR, G1-130 VSWIR, G1-812 UV, and G1-1240m/c models in <a href="#">Alvium G1 model specifications</a> on page 51 and in <a href="#">Lenses: Focal length vs. field of view</a> on page 120.</li> <li>Corrected the width value in the specifications for <a href="#">Alvium G1-1620m/c</a> on page 97.</li> </ul> <p>Continued on next page</p>

Table 2: Document history



Version	Date	Remarks
V1.3.0	2023-Jan-09	<p>Continued from previous page</p> <ul style="list-style-type: none"> <li>Added values for minimum bandwidth to reach maximum frame rates in <a href="#">Alvium G1 model specifications</a> on page 51.</li> <li>Correct contents in <a href="#">Operating systems and bandwidth</a> on page 179.</li> <li>Applied editorial changes.</li> </ul>
V1.2.2	2022-Nov-14	<ul style="list-style-type: none"> <li>Updated the title image.</li> <li>Added note that lenses are not part of the product.</li> <li>Updated values for the operating temperature range of <a href="#">Alvium G1-510m/c</a> on page 78.</li> </ul>
V1.2.1	2022-Oct-27	<p><b>Firmware version:</b> 00.11.00.9cf0c21e</p> <ul style="list-style-type: none"> <li>Updated standard references in <a href="#">Applied standards</a> on page 42.</li> <li>Added note on deviations from stated frame rates in <a href="#">Operation for maximum frame rates</a> on page 46.</li> <li>Replaced previous calculated values for ROI frame rates by measured values in <a href="#">Alvium G1 model specifications</a> on page 51.</li> <li>Changed maximum gain of Sony IMX global shutter cameras in <a href="#">Alvium G1 model specifications</a> on page 51 from 24 dB to 48 dB.</li> <li>Changed status for Alvium G1-510 models in <a href="#">Alvium G1 model specifications</a> on page 51 to available.</li> <li>Changes to <a href="#">Camera feature availability</a> on page 118:           <ul style="list-style-type: none"> <li>Added Burst Mode for image acquisition</li> <li>Removed Image Chunk Data.</li> <li>Added Sequencer.</li> <li>Added Burst Mode for image acquisition.</li> <li>Removed Image Chunk Data.</li> <li>Added Sequencer.</li> </ul> </li> <li>Added contents for Ethernet Flow Control to avoid dropped frames in <a href="#">NIC driver settings</a> on page 168.</li> </ul> <p>Continued on next page</p>

Table 2: Document history

Version	Date	Remarks
V1.2.1	2022-Oct-27	Continued from previous page <ul style="list-style-type: none"> <li>Added <a href="#">Reference system</a> on page 180 for measurements of ROI frame rates.</li> <li>Applied editorial changes.</li> </ul>
V1.2.0	2022-Sep-19	<ul style="list-style-type: none"> <li>Added Hebrew contents to <a href="#">Read before use</a> on page 2.</li> <li>Changed units KB to KByte, MB to MByte, and MBps to MByte/s for clarity.</li> <li>Updated notes for PoE power in <a href="#">Product safety</a> on page 36, <a href="#">Powering up the camera</a> on page 144, and <a href="#">I/Os: Precautions</a> on page 146.</li> <li>Updated data in <a href="#">Alvium G1 model specifications</a> on page 51:               <ul style="list-style-type: none"> <li>Changed status for Alvium G1-234 models to available and adjusted pixel formats.</li> <li>Added values for the power consumption and ROI frame rates for Alvium G1-510 models.</li> <li>Added Alvium G1-1240 models to <a href="#">Alvium G1 model specifications</a> on page 51 and <a href="#">Lenses: Focal length vs. field of view</a> on page 120.</li> </ul> </li> </ul>
V1.1.2	2022-Aug-08	<ul style="list-style-type: none"> <li>Removed data for Alvium G1-235 models from <a href="#">Alvium G1 model specifications</a> on page 51 and <a href="#">Lenses: Focal length vs. field of view</a> on page 120.</li> <li>Reverted change for the maximum gain of Sony IMX global shutter cameras in <a href="#">Alvium G1 model specifications</a> on page 51 from 48 dB back to 24 dB.</li> </ul>
V1.1.1	2022-Jul-22	Added values for minimum and maximum exposure times in <a href="#">Alvium G1 model specifications</a> on page 51.
V1.1.0	2022-Jul-20	<b>Firmware version:</b> 00.10.00.2cf3b22e <ul style="list-style-type: none"> <li>Replaced notes to inquire with Allied Vision Sales representatives by download links to the Allied Vision website.</li> <li>Removed notes for early production cameras from <a href="#">Consider for Alvium G1 cameras</a> on page 16.</li> </ul> Continued on next page

Table 2: Document history

Version	Date	Remarks
V1.1.0	2022-Jul-20	<p>Continued from previous page</p> <ul style="list-style-type: none"> <li>• Added G1-235m/c model in <a href="#">Alvium G1 model specifications</a> on page 51 and in <a href="#">Lenses: Focal length vs. field of view</a> on page 120.</li> <li>• Updated data in <a href="#">Alvium G1 model specifications</a> on page 51:               <ul style="list-style-type: none"> <li>- Values for operating temperature</li> <li>- ROI frame rates and exposure time ranges</li> <li>- Maximum gain for Sony IMX global shutter cameras increased to 48 dB.</li> </ul> </li> <li>• Added new functionalities to <a href="#">Camera feature availability</a> on page 118.</li> <li>• Added <a href="#">I/O use for UART</a> on page 149.</li> <li>• Added support for DPC and FPNC in <a href="#">Image data flow</a> on page 159.</li> <li>• Removed the sections “Feature validation status” and “Feature value changes on a streaming camera” from <a href="#">Performance and troubleshooting</a> on page 166.</li> <li>• Applied editorial changes.</li> </ul>
V1.0.4	2022-Jun-08	<ul style="list-style-type: none"> <li>• Added <a href="#">Camera identification</a> on page 32, including Model ID for DoC assignment.</li> <li>• Replaced calculated values for power consumption in <a href="#">Alvium G1 model specifications</a> on page 51 by measured values.</li> <li>• Updated data for Alvium G1-234m/c in <a href="#">Alvium G1 model specifications</a> on page 51.</li> <li>• Added warning against voltage levels of serial communication and wrong polarity of external power in <a href="#">I/Os: Precautions</a> on page 146.</li> <li>• Applied editorial changes.</li> </ul>
V1.0.3	2022-May-19	<ul style="list-style-type: none"> <li>• Rounded values in <a href="#">Dimensions and mass</a> on page 110 from 62 g to 65 g in order to match conventions for Alvium cameras.</li> <li>• Adapted descriptions in <a href="#">Table 86: TFM I/O connector pin assignment</a> on page 148 to ease the comparison with previous Allied Vision GigE cameras.</li> <li>• Applied editorial changes.</li> </ul>
V1.0.2	2022-May-09	<p>Added advice in <a href="#">ESD</a> on page 36.</p>

Table 2: Document history

Version	Date	Remarks
V1.0.1	2022-Apr-28	<ul style="list-style-type: none"> <li>Reversed maximum operation temperature in <a href="#">Alvium G1 model specifications</a> on page 51 from concremented values to “tbd”.</li> <li>Added notes against material damage for GPIOs with PoE power in <a href="#">I/Os and GPIOs</a> on page 149.</li> <li>Added <a href="#">Tips and tricks to connect 1000BASE-T</a> on page 167.</li> <li>Applied editorial changes.</li> </ul>
V1.0.0	2022-Apr-12	<b>Firmware version:</b> 00.09.00.e23cb4e8 Release version

Table 2: Document history

## Conventions used in this user guide

To give this manual an easily understood layout and to emphasize important information, the following typographical styles and symbols are used.

### Typographic styles

Style (example)	Function
<b>Emphasis</b>	Programs, or highlighting important things
Feature names	GenlCam features names
<i>Feature options</i>	Features options and register’s options that are selectable by the user
<b>UI Element</b>	Text that is displayed, or output, by the system for the user, like parts of the GUI, dialog boxes, buttons, menus, important information, windows titles.
<a href="#">Reference</a>	Links to webpages and internal cross references

Table 3: Typographic styles

## Symbols and notes



### CAUTION

#### **Risk of burns**

Precautions are described



### CAUTION

#### **Injury by falling cameras or lenses**

Precautions are described



### CAUTION

#### **Risk of cuts by sharp edges of lens mounts**

Precautions are described



### NOTICE

#### **Material damage or violation of data security**

Precautions are described.



#### **Practical Tip**

Additional information helps to understand or ease handling the camera.



#### **Avoiding malfunctions**

Precautions are described.



#### **Additional information**

Web link or reference to an external source with more information is shown.

## Acronyms and terms

The following table provides a list of acronyms and terms used in this document.

Acronym or term	Description
ADC	Analog to Digital Converter
AIA	Automated Imaging Association
CRA	Chief ray angle
EMVA	European Machine Vision Association
ERS	Electronic rolling shutter also known as “rolling shutter”
ESD	Electrostatic Discharge
FCC	Federal Communications Commission
FOV	Field of view
FPNC	Pixed pattern noise correction
fps	Frames per second
GenICam	Generic Interface for Cameras, EMVA
GND	Ground (power)
GPIOs	General purpose inputs and outputs (non-isolated)
GRRS	Global reset release shutter, see GRS
GRS	Global reset shutter, see GRRS
GS	Global shutter
H × V	Horizontal × Vertical (sensor resolution)
KByte	Kilobyte
MByte	Megabyte
MByte/s	Megabyte per second
MP	Megapixels (see P)
N.a.	Not applicable (in tables)
NIC	Network interface card
P	Pixels (see MP)
PSE	Power sourcing equipment
QE	Quantum efficiency
RoHS	Restriction of Hazardous Substances Directive
ROI	Region of interest
RS	Rolling shutter
SFNC	Standard Feature Naming Convention (GenICam)
shutter mode	Value of the <b>ShutterMode</b> feature to select between rolling shutter (RS) and global release shutter (GRS)
shutter type	Sensor specific readout, such as rolling shutter (RS) or global shutter (GS)
S-Mount	M12-Mount

Table 4: Acronyms and terms

# Compliance, safety, and intended use



This chapter includes:

Camera identification.....	32
Compliance notifications .....	32
Intended use .....	34
Copyright and trademarks .....	34
Your safety.....	35
Product safety .....	36

## Camera identification

You can identify your Alvium G1 camera like this:

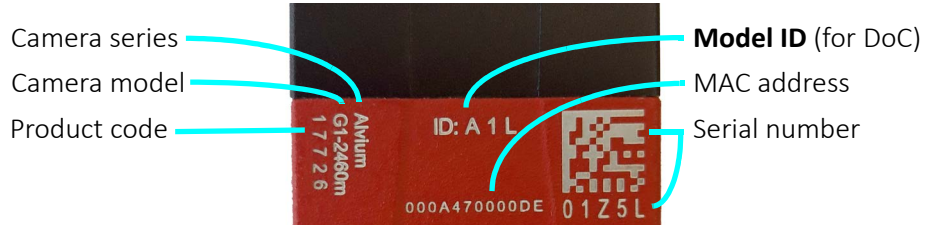

Closed housing Alvium G1 cameras have the Model ID: **A 1 L**.

## Compliance notifications



National regulations on disposal must be followed.

### For customers in the US



#### Class B digital device

This equipment has been tested and found to comply with the limits for a Class B digital device, pursuant to part 15 of the FCC Rules. These limits are designed to provide reasonable protection against harmful interference in a residential installation. This equipment generates, uses and can radiate radio frequency energy and, if not installed and used in accordance with the instructions, may cause harmful interference to radio communications. However, there is no guarantee that interference will not occur in a particular installation. If this equipment does cause harmful interference to radio or television reception, which can be determined by turning the equipment off and on, the user is encouraged to try to correct the interference by one or more of the following measures:

- Reorient or relocate the receiving antenna.
- Increase the separation between the equipment and receiver.
- Connect the equipment into an outlet on a circuit different from that to which the receiver is connected.
- Consult the dealer or an experienced radio/TV technician for help.

#### Supplier Declaration of Conformity

Alvium G1 cameras comply with Part 15 of the FCC Rules. Operation is subject to the following two conditions:

1. This device may not cause harmful interference, and
2. This device must accept any interference received, including interference that may cause undesired operation.



## Party issuing Supplier's Declaration of Conformity

Allied Vision Technologies GmbH  
Taschenweg 2a  
07646 Stadtroda, Germany  
T// +49 (36428) 677-106  
quality@alliedvision.com

## Responsible party - US contact information

Allied Vision Technologies, Inc.  
102 Pickering Way – Suite 502  
Exton, PA 19341, USA  
T// +1 978 225 2030

**Note:** changes or modifications not expressly approved by the party responsible for compliance could void the user's authority to operate the equipment.

## For customers in Canada

This apparatus complies with the Class B limits for radio noise emissions set out in the Radio Interference Regulations.

CAN ICES-3 (B) / NMB-3 (B)

## Pour utilisateurs au Canada

Cet appareil est conforme aux normes classe B pour bruits radioélectriques, spécifiées dans le Règlement sur le brouillage radioélectrique.

CAN ICES-3 (B) / NMB-3 (B)

## Avoid electromagnetic interferences

Interface cables, power cables, and I/O cables are sensitive to electromagnetic interference.

- Use shielded cables only.
- We recommend using cables offered by Allied Vision.
- Avoid coiling.
- We recommend using GPIOs only in environments with low electromagnetic interference.

Moreover, avoid unnecessary bending to prevent damage to the cables.

## Intended use

Allied Vision's objective is the development, design, production, maintenance, servicing and distribution of digital cameras and components for image processing. We are offering standard products as well as customized solutions.

Intended use of Allied Vision product is the integration into Vision systems by professionals. All Allied Vision product is sold in a B2B setting.

Allied Vision isn't a legal manufacturer of medical product. Instead, Allied Vision cameras and accessories may be used as components for medical product after design-in by the medical device manufacturer and based on a quality assurance agreement (QAA) between Allied Vision (supplier) and medical device manufacturer (customer). Allied Vision's duties in that respect are defined by ISO 13485, clause 7.2 (customer-related processes, equivalent to ISO 9001, clause 8.2).

## Copyright and trademarks

All text, pictures, and graphics are protected by copyright and other laws protecting intellectual property. All content is subject to change without notice.

All trademarks, logos, and brands cited in this document are property and/or copyright material of their respective owners. Use of these trademarks, logos, and brands does not imply endorsement.

Copyright © 2023 Allied Vision GmbH. All rights reserved.

## Your safety

This section informs about issues related to your personal safety. Descriptions explain how to avoid hazards and operate Alvium G1 cameras safely.

### Handling lens mounts

The lens mount thread has sharp edges. Be careful these edges do not cut your skin when mounting or unmounting lenses.

### Handling hot cameras

Depending on the individual setup, Alvium G1 cameras can exceed the specified maximum operating temperature. In many cases, mounting the camera on a metal surface or using a lens will be sufficient to cool the camera effectively. However, especially when operated in higher ambient temperatures, additional measures for heat dissipation, such as using a heat sink, should be considered.

If you have doubts or questions, please feel free to contact your Allied Vision Sales representative for support!

If the mainboard temperature exceeds the specified maximum for more than two seconds, the camera is powered off automatically. The current value for mainboard temperature is output by `DeviceTemperature`. You can use this value to control cooling by software, for example, to control a fan.

However, if you hold the camera in your hands during operation, your skin may get hurt. If you touch the camera when it is heated up, we recommend wearing protective gloves.

### Providing optimum heat dissipation

Keep the operating temperature in the specified range to enable best image quality and to protect the camera from damage.

For your safety and to improve image quality, we recommend operating the camera:

- Mounted to a base with a high thermal conductivity
- With lens or other optical components mounted
- With a heat sink mounted that has large surface areas
- Using conductive media for camera and heat sink mounting
- With active cooling of camera, mounting base, and heat sink, such as by ventilation.
- Reduce high ambient temperature. For example, in outdoor applications with direct sunlight, provide shading by an enclosure.

## Camera mounting

Cameras must be mounted using the mounting threads. If vibration is higher than specified, cameras can disconnect from the mounting. Falling cameras can hurt you. To avoid personal injury:

- Mount the camera according to the instructions in [Mounting Alvium G1 cameras](#) on page 134.
- Ensure, shock and vibration do not exceed the specified range, see [Shock and vibration](#) on page 42.
- Use a lens support if you want to use [Heavy lenses](#).

## Heavy lenses

For non-static applications, use lenses with a mass less than 140 grams and a length less than 38 mm, where the center of gravity is 20 mm, measured from the lens mount front flange. For heavier or longer lenses, use a lens support and apply additional tests. For more information, please contact support at [www.alliedvision.com/en/about-us/contact-us/technical-support-repair-/-rma](http://www.alliedvision.com/en/about-us/contact-us/technical-support-repair-/-rma).



### Applied mechanical tests

See [Shock and vibration](#) on page 42 for standards compliance.

## Product safety

To prevent material damage, read the following and understand how to safely handle and operate the camera. Get helpful details about electrical connections and learn how to optimize camera performance.

## Electrical connections

### ESD

ESD is dangerous for electronic devices, especially when tools or hands get in contact with connectors and electronic components. We recommend measures to avoid damage by ESD:

- Unpacking: Remove the camera from its anti-static packaging only when your body is grounded.
- Workplace: Use a static-safe workplace with static-dissipative mat and air ionization.
- Wrist strap: Wear a static-dissipative wrist strap to ground your body.
- Clothing: Wear ESD clothing. Keep components away from your body and clothing. Even if you are wearing a wrist strap, your body is grounded but your clothes are not.
- Screw-locks: Tighten screw locks of all cabling prior powering the camera. Do not touch locking screws during operation to prevent camera malfunction.

## Cable connections

Provide sufficient strain relief for all cable connections to avoid short circuits and malfunctions.

## Camera power

Operating the camera beyond the specified range damages the camera.

Cameras can be powered using the I/O connector at an input range of 12 to 24 VDC, using a limited power source (LPS), according to IEC 62368-1 with minimum 2.0 A. The camera is not intended to be connected to a DC distribution network.

Alternatively, cameras can be powered over Ethernet. However, power consumption and heat generation are higher than with external power, using the I/O connector.

- Make sure that PoE power sourcing equipment is at least compliant to IEEE 802.3af.
- Only use power supplies that meet the insulation requirement according to PELV or SELV. For details, please refer to IEC 61140.
- If using external power supplies by third-party manufacturers, observe polarity to avoid damage to the camera electronics.



### PoE versus external power

Powering the camera via PoE results in higher power consumption and heat generation than external power, resulting in higher energy costs and requiring more efficient heat dissipation.



### External power supply

For the 13870 10-pin TFM power supply, see [www.alliedvision.com/en/support/accessory-documentation](http://www.alliedvision.com/en/support/accessory-documentation).

## PoE Power Sourcing Equipment (PSE)

Damage to the camera or connected peripherals can occur if PSE is not galvanically isolated from mains and other electrical connections towards the camera (other than Ethernet signals and shield ground).

To avoid damage

- Only use IEEE802.3af/at compliant PSE equipment to power the camera via PoE.
- Ensure the PSE is galvanically isolated from mains and all other electrical connections towards the camera.

## I/Os and power supply by PoE

The PoE implementation is non-isolated. Therefore, when the camera is connected to a PoE-capable Ethernet port:

- Only connect the pins 3, 4, 5, 6 and 10 (isolated I/Os) of the TFM connector.
- **Do not** connect any other pins of the TFM connector.

See [Camera interfaces](#) on page 145 for details.

## I/Os

To avoid damage to the camera, keep the maximum values for

- Isolated I/Os: Input voltage below 24 VDC, output current below 20 mA per output.
- Non-isolated GPIOs: Input voltage below 5.5 VDC, output current below 12 mA.

See [Alvium G1 model specifications](#) on page 51 for details. The maximum length for I/O cables must not exceed 30 meters.



### Power supply via I/O cables

If you power the camera via an I/O cable, consider the voltage drop to meet the minimum supply voltage for the camera.

## GigE connection

### GigE NICs

To avoid damage to GigE NICs and injectors, make sure that PoE power sourcing equipment is at least compliant to IEEE 802.3af.



### GigE accessories

For GigE interface cables, NICs, switches, and more, see [www.alliedvision.com/en/support/accessory-documentation](http://www.alliedvision.com/en/support/accessory-documentation).

### Ethernet cables

Proper cable handling enables reliable performance:

- We recommend Category 6 (CAT6) or higher rated Ethernet cables for Alvium G1 cameras. A different rating may not sustain peak interface bandwidth; leading to lost connectivity or dropped frames coming from the camera. .
- Use only shielded cables to avoid electromagnetic interferences.
- Please use cables recommended by Allied Vision.
- Avoid unnecessary bending to prevent damage to the cables.
- Avoid coiling to prevent electromagnetic interference.

## Optical components

Provide the following conditions to keep dirt and droplets out of the optical system of camera and lens:

- Dust-free environment
- Low relative humidity
- No condensation.

When camera or lens are stored:

- Cover the lens mount with a protection foil or cap.
- Cover front and back lens with caps.

## Sensor

Sensors are sensitive to excessive radiation: focused sunlight, UV light, lasers, and X-rays can damage the sensor. Dirt and scratches can damage the sensor as well.

Alvium G1 cameras do not need additional cleaning. Cameras are cleaned before shipping. Incorrect cleaning can damage the sensor or the filter. Therefore, never clean the sensor or the filter.

Protect the camera filter and the sensor from dirt, because dirt becomes more visible the closer it gets to the sensor. In addition, keep the back lens clean. Hold the camera with the lens mount facing the ground to keep dirt out of the lens mount. When no lens is mounted, protect the sensor and filter by a dust cap.

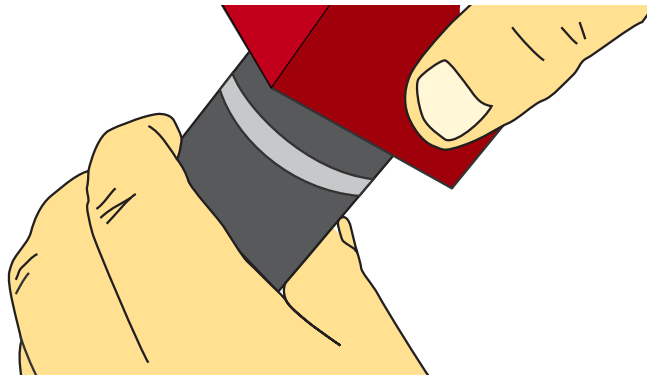
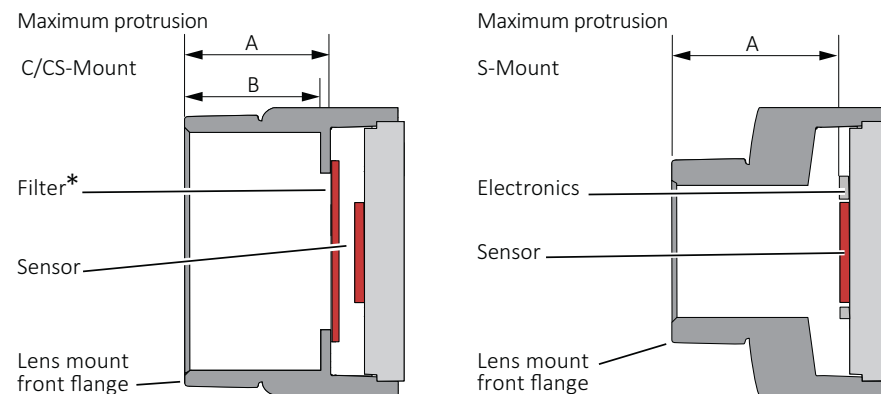

*Figure 1: Holding the camera with the lens mount facing the ground*

## Lenses

### Maximum protrusion

The sensor, filter, or lens can be damaged if a lens exceeding maximum protrusion is mounted to the camera. Use lenses with a maximum protrusion within camera specifications. [Figure 2](#) shows schematics for maximum protrusion. For details, see [Lens mounts and maximum protrusion](#) on page 113.



\*Only color models are equipped with an IR cut filter

Figure 2: Maximum protrusion C-Mount and CS-Mount (left); S-Mount (right)

For S-Mount lenses, read [Mounting and focusing S-Mount lenses](#) on page 137 to avoid damage to the sensor, the electronics, and lens.

## Mechanical components

### Heat sinks

Heat sinks can be used to cool the camera for safety and to improve image quality. Adhere to the instructions provided by the manufacturer of the heat sink.

### Conductive media

Some conductive media for heat sinks contain corrosive substances that can damage optical surfaces of the sensor, filter, and lens.

- Cover the optical path of the camera when you apply heat sink compound or adhesive to prevent substances and fumes from damaging optical surfaces.
- Adhere to the instructions and safety notes provided by the manufacturer of the conductive media.
- Ensure that the conductive media is correctly positioned: covering only the components to be cooled.



# Specifications



This chapter includes:

Applied standards .....	42
Notes on specifications .....	45
Alvium G1 model specifications.....	51
White balance default.....	109
Dimensions and mass .....	110
Technical drawings .....	110
Lens mounts and maximum protrusion .....	113
IR cut filter.....	114
Sensor position accuracy .....	115
User sets.....	117
Camera feature availability .....	118

# Applied standards

## GenICam

GenICam provides a generic access to cameras and devices that is independent of the interface. This enables operating cameras with USB3 Vision, GigE Vision, or CoaXPress interfaces with a common software.

GenICam consists of multiple modules for different tasks. Allied Vision cameras and software use these modules, such as the SFNC that standardizes feature names and types via an XML file.

Alvium G1 cameras comply to:

- GigE Vision Standard Version 1.2
- GenICam Standard Document Version 2.1.1
- GenAPI Schema Version 1.1
- GenAPI Version 3.1
- GenICam Standard Features Naming Convention (SFNC) Version 2.7
- GenICam Pixel Format Naming Convention (PFNC) Version 2.2

## GigE Vision

The GigE Vision standard specifies a UDP based protocol for machine vision and imaging products. It provides control over compliant devices by GenICam Applications Programming Interface (API). The GigE Vision standard is administered by the Automated Imaging Association (AIA).

## IP class

Equipped with a lens as intended, Alvium G1 cameras comply with IP30 class according to IEC 60529.

## Shock and vibration

Alvium G1 cameras were tested successfully according to the following standards:

- IEC 60068-2-6, sinusoidal vibration testing
- IEC 60068-2-27, shock testing
- IEC 60068-2-64, random vibration testing.

Cameras were inspected before and after the tests. All tests were passed successfully:

Condition	Passed
Mechanics	<ul style="list-style-type: none"> <li>The camera housings showed no deformations.</li> <li>The connections between camera components had not come loose.</li> <li>The sensor position was within the specified tolerances of a new camera.</li> </ul>
Camera behavior	Camera functionalities were not affected, no deviations occurred.
Image streaming	Images were streamed without errors.

*Table 5: Conditions for passed tests*

The conditions for cameras and lenses were the same for all tests. Solid aluminum tubes were used to represent real lenses:

Parameter	Value
Lens dummy length	22 mm
Lens dummy mass	70 g
Center of gravity (CoG) <sup>1</sup>	17 mm

<sup>1</sup>For camera and lens dummy assemblies, measured from the lens mount front flange

*Table 6: Conditions for lenses*

## IEC 60068-2-6: Sinusoidal vibration

Frequency	Acceleration	Displacement
10 Hz to 58.1 Hz	Not applicable	1.5 mm
58.1 Hz to 500 Hz	20 g	Not applicable

*Table 7: Frequency, acceleration, and displacement for IEC 60068-2-6 tests*

Parameter	Value
Axis <sup>1</sup>	x, y, z
Sweep rate	1 oct/min
Sweep duration per axis [hh:mm:ss]	03:45:40
Number of sweeps	10

<sup>1</sup>For technical reasons, all three axes are tested with the shaker in the upright position without a sliding table.

*Table 8: Other parameters for IEC 60068-2-6 tests*

## IEC 60068-2-27: Shock

Parameter	Value
Axis	x, y, z
Acceleration	20 g
Number of shocks per axis	10
Duration per axis	11 ms
Waveform	Half sine

Table 9: Parameters for IEC 60068-2-27 tests

## IEC 60068-2-64: Random vibration

Frequency	Acceleration
15 Hz to 500 Hz	0.05 g <sup>2</sup> /Hz

Table 10: Frequency and acceleration for IEC 60068-2-64 tests

Parameter	Value
Axis	x, y, z
Acceleration RMS (Sigma)	4.9 g
Acceleration peak (Sigma)	14.8 g
Duration per axis [hh:mm:ss]	00:30:00

Table 11: Other parameters for IEC 60068-2-64 tests

# Notes on specifications

This section defines the conditions for specifications stated in this chapter.

## Sensor

### Absolute QE plots

Measurements for color cameras were done with IR cut filter. Measurements for monochrome and S-Mount cameras were done without optical filters. With protection glass or filters, QE decreases by approximately 10 percent.

The uncertainty in measurement of the QE values is  $\pm 10$  percent. This is mainly due to uncertainties in the measuring apparatus itself (such as Ulbricht sphere and optometer).

Manufacturing tolerance of the sensor increases overall uncertainty.

### ON Semiconductor sensors

The curve in the absolute QE plots shown in this chapter is taken from the sensor manufacturer data sheet. The information was correct at the time of publishing.

### Sony sensors

Sony provides relative response curves in their sensor data sheets. To create the absolute QE plots shown in this chapter, the relative response was converted to a normalized QE response and then adjusted as per three measured QE values (at 448 nm, 529 nm, 632 nm) for color sensors and one measured QE value (at 529 nm) for monochrome sensors.

### Wavelength

The wavelength range in the absolute QE plots reflects the information available in the sensor manufacturer data sheet at the time of publishing. Many color sensors are documented by the sensor manufacturer only for wavelengths from 400 nm to 700 nm.

### Spectral response plots

The curves in the spectral response plots shown in this chapter were calculated from measured quantum efficiencies at 448 nm, 529 nm, and 632 nm. The shape of the curve is taken from the sensor data sheet, but the values have been adjusted based on these measured values. The uncertainty in measurement of the spectral response values is  $\pm 10$  percent.

## Exposure time and frame rates

### Specified values

Stated values were calculated (see [Operation for maximum frame rates](#)), then verified with the [Reference system](#) on page 180.

### Operation for maximum frame rates

Values for maximum frame rates and for minimum and maximum exposure time in the specification tables were measured, based on following parameters:

- Factory settings (camera after power up)
- Minimum exposure time
- Full resolution
- Mono8 pixel format or 8-Bit Bayer pixel format
- Camera operation in freerun mode
- Minimum value for `SensorBitDepth` (8-bit sensor ADC readout mode if available)
- Bandwidth required for the corresponding frame rate, as stated in the tables for ROI frame rates.

**Bandwidth:** Values were measured for 12 MByte/s and 122 MByte/s.

**Bit depth:** Values are measured for Mono8. If you are using color formats or 10-bit or 12-bit pixel formats, frame rates fall below values for Mono8. If `DeviceLinkThroughputLimit` is enabled, you can increase the `DeviceLinkThroughputLimit` value to increase maximum frame rates.

**Triggering:** If cameras are triggered, frame rates are lower.

**Deviations from stated frame rates** can occur, especially when:

- The camera is operated in triggered mode
- Low bandwidth is used
- Small ROIs are used.

### Factors for exposure time and frame rates

- The **default bandwidth** for Alvium G1 cameras is 115 MByte/s. For some models, you can achieve higher frame rates by increasing values for `DeviceLinkThroughputLimit`. See [Operating systems and bandwidth](#) on page 179.
- Available values and increments for **exposure time** depend on other controls, such as `DeviceLinkThroughputLimit`. See [Value changes by feature interdependencies](#) on page 175.
- For **delays**, see [Exposure start delay = exposure area – exposure time](#). on page 157.
- Calculation of maximum **frame rates for different ROIs** for Alvium G1 cameras does not allow to give a formula. [Operation for maximum frame rates](#) on page 46 defines the conditions for measuring ROI frame rates.

## Sensor ADC readout modes for maximum frame rates

If you are using pixel formats that do not require 12-bit sensor ADC readout and you want to achieve higher frame rates, you can select between readout modes for 12-bit, 10-bit, and 8-bit with some Alvium G1 camera models. See your model's specifications.

By default, Alvium G1 models use the maximum bit depth for **SensorBitdepth**. For selected models, *Adaptive* mode switches automatically between 12-bit and 10-bit sensor ADC readout, depending on the bit depth of the selected pixel format. This allows to reduce bandwidth and increase frame rates when only 10-bit is required.

To enable the 8-bit sensor readout mode, you must switch manually, using **SensorBitdepth**. Please observe that the image brightness changes when you switch between 8-bit sensor ADC readout mode and the other readout modes.

## Exposure time behavior regarding ExposureMode

This section informs about how exposure time behaves in the different exposure modes. All Alvium cameras have an exposure time offset. The exposure time offset and the exposure time increment depend on sensor and camera characteristics. Both, the exposure time offset and the exposure time increment, can change if **Width**, **PixelFormat**, or **DeviceLinkThroughputLimit** are changed. See [Value changes by feature interdependencies](#) on page 175.

### ExposureMode = Timed

For all Alvium cameras, exposure time can be set by **ExposureTime** or **ExposureAuto**. For this, **ExposureMode** is set to *Timed*.

The selected exposure time is extended automatically:

- If the selected exposure time does not match the available increment, the camera automatically extends the exposure time to the next increment.
- The **exposure time offset is included** in the selected exposure time.

### ExposureMode = TriggerWidth or TriggerControlled

In addition, most global shutter (GS) cameras can control exposure time by the trigger signal, with the **ExposureMode** set to *TriggerWidth* or *TriggerControlled* (using **ExposureStart** and **ExposureStop**).

The trigger controlled exposure time is extended automatically:

- If the trigger controlled exposure time does not match the available increment, the camera automatically extends the exposure time to the next increment.
- Subsequently, the **exposure time offset is added**.

You can use *ExposureActive* to determine the duration of the exposure time offset.

## Triggering and sensor shutter types

Triggering behavior differs between cameras with global shutter (GS) and electronic rolling shutter (ERS).

### Triggering

The following table shows how the shutter mode impacts available frame rates:

Sensor type	Shutter mode	Trigger mode	Available frame rates	ROI frame rates
Global shutter	Global shutter	Freerun	Maximum values	Increased values
	Global shutter	External trigger	Maximum values	Increased values
Rolling shutter	Rolling shutter	Freerun	Maximum values	Increased values
	Rolling shutter	External trigger	<b>Reduced values</b>	Increased values
	Global reset shutter (GRS)	Freerun	Maximum values	<b>No increase</b>
	Global reset shutter (GRS)	External trigger	Maximum values	<b>No increase</b>

Table 12: Frame rates depending on shutter modes and trigger modes



#### Achieved frame rates may not match specified values

- Some sensors have an exposure start jitter that may reduce maximum frame rates.
- Your individual setup may cause delays in data transmission.



#### Bandwidth adjustments

Consider the bandwidth available for camera payload depends on your individual hardware, the operating system, software and drivers, and your application. We recommend you to adjust `DeviceLinkThroughputLimit` to your requirements.



#### Interdependencies between ROI and ExposureTime values

Changing parameters for ROI can affect values for `ExposureTime`, such as minimum, maximum, and increments, but `ExposureTime` itself as well. We recommend you to set:

- ROI values
- `DeviceLinkThroughputLimit`

before you set values for `ExposureTime`.

See [Value changes by feature interdependencies](#) on page 175 for details.



## Digital binning

Alvium G1 cameras combine digital horizontal binning and digital vertical binning, for integer values 1 to 8.



### Alvium G1 models $\geq 12$ MP resolution

If digital horizontal and digital vertical binning are set to 1x and the digital vertical binning value is increased, digital horizontal binning is automatically set to 2x.

## Sensor binning

Selected camera models support sensor binning in addition. See the specifications tables in [Alvium G1 model specifications](#) on page 51.

## Multiple regions

All Alvium G1 models support single ROI (region of interest). Because multiple ROI (**MultipleRegions** features) are sensor based, it is not supported by all camera models. With all the corresponding models, *Free* mode is available for **MultipleRegionArrangement** with 1 to 4 subregions. Other models also support *Tile* mode, some models also support *Horizontal* and *Vertical* mode with 1 to 4 subregions. See [Table 13](#).





Mode	Sensor input	Camera output
<i>Free</i>		
<i>Tile</i>		

Table 13: Modes for MultipleRegions (sheet 1 of 2)

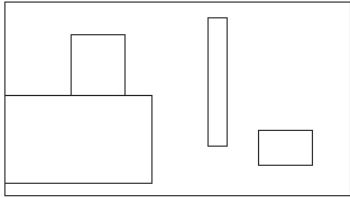

Mode	Sensor input	Camera output
<i>Horizontal</i>		
<i>Vertical</i>		

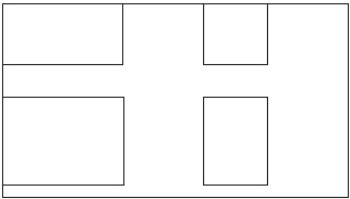
Table 13: Modes for MultipleRegions (sheet 2 of 2)

See the specifications tables in [Alvium G1 model specifications](#) on page 51 for model details.

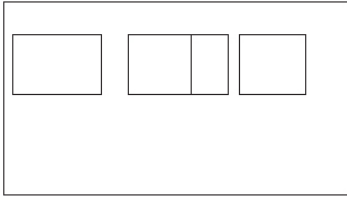

#### Using multiple regions

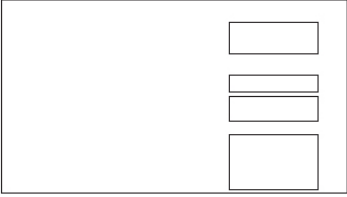
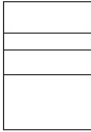
Alvium Features Reference: [www.alliedvision.com/en/support/technical-documentation/alvium-gige-documentation](http://www.alliedvision.com/en/support/technical-documentation/alvium-gige-documentation).

## Operation for typical power consumption

Values for typical power consumption and housing temperature ranges in the specification tables are based on following parameters:

- Factory settings (camera after power up)
- Minimum exposure time
- Maximum frame rate
- Full resolution
- Mono8 pixel format or 8-Bit Bayer pixel format
- Camera operation in freerun mode
- Sensor ADC readout using maximum bit depth
- Without bandwidth limitations.

## Dimensions and mass

For your model's dimensions, see [Dimensions and mass](#) on page 110. For technical drawings, see [Technical drawings](#) on page 110.

# Alvium G1 model specifications

## Alvium G1-030 VSWIR

Feature	Specification
	<b>G1-030 VSWIR</b>
Sensor model	Sony IMX991
Resolution	656 (H) × 520 (V); 0.3 MP
Sensor type	InGaAs
Shutter type	Global shutter (GS)
Sensor size	Type 1/4; 3.28 mm × 2.6 mm; 4.1 mm diagonal
Pixel size	5 μm × 5 μm
CRA	0 deg
Sensor bit depth (ADC)	8-bit, 10-bit, 12-bit; Adaptive (10-bit, 12-bit)
Monochrome pixel formats	Mono8 (default), Mono10, Mono10p, Mono12, Mono12p
Maximum frame rate	249 fps (at ≥93 MByte/s)
Exposure time	22 μs to 7 s (at 93 MByte/s)
Exposure modes	Timed, TriggerControlled, TriggerWidth
Gain	0 dB to 42 dB; 0.1 dB increments
Digital binning	Horizontal: 1 to 8 columns; Vertical: 1 to 8 rows
Multiple ROI (H × V)	<i>Free   Tile   Horizontal: 1 × 1 to 1 × 4   Vertical: 1 × 1 to 4 × 1</i>
Image buffer (RAM)	32 MByte
Non-volatile memory (Flash)	1024 KByte
Inputs and outputs	1 opto-isolated input, 1 opto-isolated output, 2 non-isolated GPIOs <sup>1</sup>
Power requirements	12 to 24 VDC
Power requirements (PoE)	IEEE 802.3af
Power consumption (typical)	External power: 2.8 W at 12 VDC Power over Ethernet: 3.1 W
Storage temperature	-20 °C to +85 °C ambient temperature
Operating temperature	-20 °C to +55 °C (Housing, typical), -20 °C to +85 °C (Mainboard <sup>2</sup> )
Humidity	0% to 80% humidity (non-condensing)
Digital interface	1000BASE-T
Camera controls	GenICam (GenICam Access)
<sup>1</sup> Use with external power only, not with PoE. See <a href="#">I/Os and power supply by PoE</a> on page 38. <sup>2</sup> Output by <code>DeviceTemperature</code>	

Table 14: Alvium G1-030 VSWIR specifications

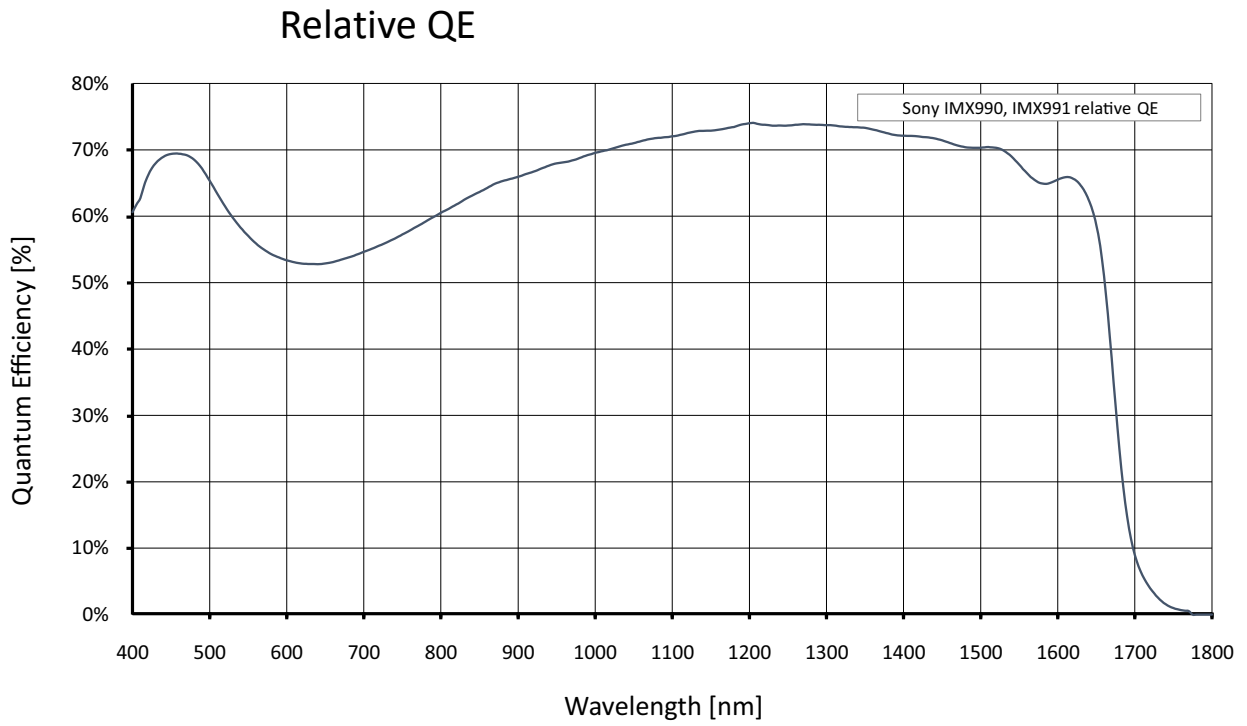

Figure 3: Alvium G1-030 VSWIR (Sony IMX991) relative QE

## ROI frame rates

Values are based on the conditions defined in [Specified values](#) on page 46. To reach the maximum frame rate available for typical operation, the bandwidth for image traffic is 93 MByte/s. Increasing the `DeviceLinkThroughputLimit` value does not increase frame rates.

Image format	Width [pixels]	Height [pixels]	ROI area [MP]	Frame rate [fps] <sup>1</sup>	
				122 MByte/s	12 MByte/s
Full resolution	656	520	0.341	249.1 / 162.5 / 132.9	32.6 / 16.4 / 16.3
VGA	640	480	0.307	268.4 / 179.2 / 142.9	36.0 / 18.1 / 18.0
HVGA	480	320	0.154	384.8 / 342.1 / 205.1	69.0 / 34.7 / 34.6
QVGA	320	240	0.077	494.0 / 457.2 / 262.7	132.4 / 66.5 / 66.4
HQVGA	240	160	0.038	686.4 / 634.4 / 365.0	243.6 / 123.2 / 122.8
QQVGA	160	120	0.019	849.9 / 789.2 / 454.6	453.6 / 229.3 / 228.6
Max. × half	656	260	0.171	450.4 / 294.6 / 241.0	59.5 / 30.0 / 29.9
Max. × min.	656	8	0.005	2340.8 / 1573.0 / 1286.7	342.0 / 172.2 / 171.6
Min. × max.	8	520	0.004	252.2 / 234.2 / 134.1	
Min. × min.	8	8	64 P	2644.2 / 2455.3 / 1405.9	

<sup>1</sup> Mono8 at `SensorBitDepth` = 8-Bit<sup>(2)</sup> / Mono10 at `SensorBitDepth` = 10-Bit / Mono12 or at `SensorBitDepth` = 12-Bit

<sup>2</sup> The `SensorBitDepth` value must be set separately from `PixelFormat`. See [Sensor ADC readout modes for maximum frame rates](#) on page 47 for details.

Table 15: Alvium G1-030 VSWIR ROI frame rates

## Alvium G1-040m/c

Feature	Specification	
	G1-040m (monochrome)	G1-040c (color)
Sensor model	Sony IMX287	
Resolution	728 (H) × 544 (V); 0.4 MP	
Sensor type	CMOS	
Shutter type	Global shutter (GS)	
Sensor size	Type 1/2.9; 5 mm × 3.8 mm; 6.3 mm diagonal	
Pixel size	6.9 μm × 6.9 μm	
CRA	0 deg	
Sensor bit depth (ADC)	8-bit, 10-bit, 12-bit; Adaptive (10-bit, 12-bit)	
Monochrome pixel formats	Mono8 (default), Mono10, Mono10p, Mono12, Mono12p	Mono8, Mono10, Mono10p, Mono12, Mono12p
YUV color pixel formats	Not applicable	YCbCr411_8_CbYYCrYY, YCbCr422_8_CbYCrY, YCbCr8_CbYCr
RGB color pixel formats	Not applicable	BayerRG8, BayerRG10, BayerRG10p, BayerRG12, BayerRG12p, BGR8, RGB8 (default)
Maximum frame rate	276 fps (at 122 MByte/s)	
Exposure time	27 μs to 10 s (at 122 MByte/s)	
Exposure modes	Timed, TriggerControlled, TriggerWidth	
Gain	0 dB to 48 dB; 0.1 dB increments	
Digital binning	Horizontal: 1 to 8 columns; Vertical: 1 to 8 rows	
Multiple ROI (H × V)	<i>Free</i>	
Image buffer (RAM)	32 MByte	
Non-volatile memory (Flash)	1024 KByte	
Inputs and outputs	1 opto-isolated input, 1 opto-isolated output, 2 non-isolated GPIOs <sup>1</sup>	
Power requirements	12 to 24 VDC	
Power requirements (PoE)	IEEE 802.3af	
Power consumption (typical)	External power: 3.1 W at 12 VDC Power over Ethernet: 3.4 W	
Storage temperature	-20 °C to +85 °C ambient temperature	
Operating temperature	-20 °C to +50 °C (Housing, typical), -20 °C to +85 °C (Mainboard <sup>2</sup> )	
Humidity	0% to 80% humidity (non-condensing)	
Digital interface	1000BASE-T	
Camera controls	GenICam (GenICam Access)	

<sup>1</sup> Use with external power only, not with PoE. See [I/Os and power supply by PoE](#) on page 38.

<sup>2</sup> Output by DeviceTemperature

Table 16: Alvium G1-040m/c specifications

### Absolute QE

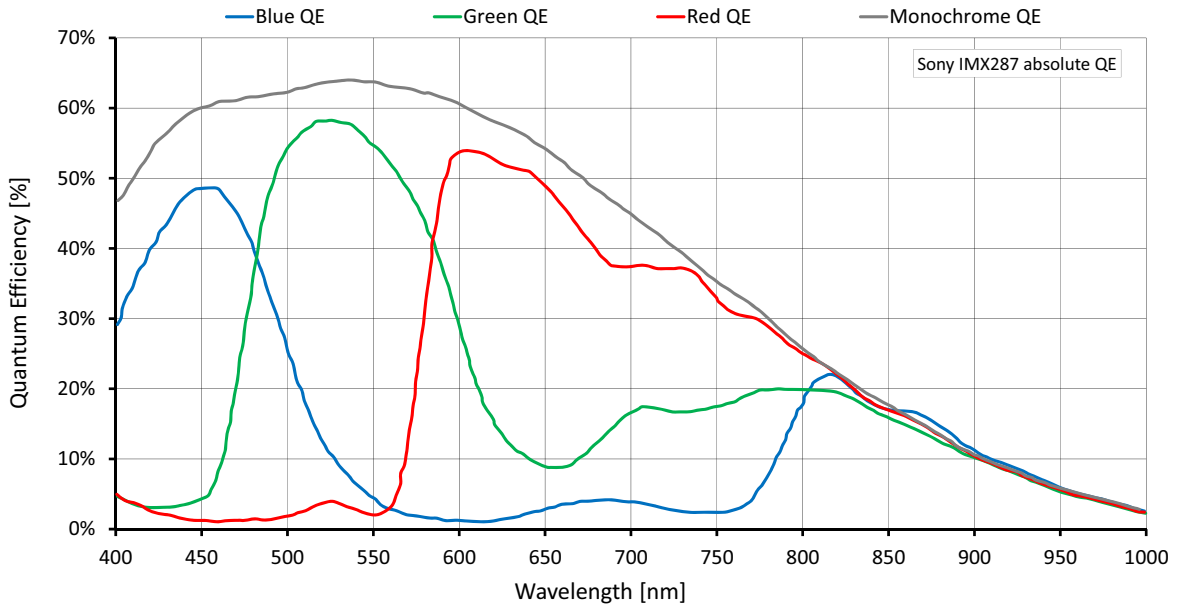

Figure 4: Alvium G1-040m/c (Sony IMX287) absolute QE

### Spectral response

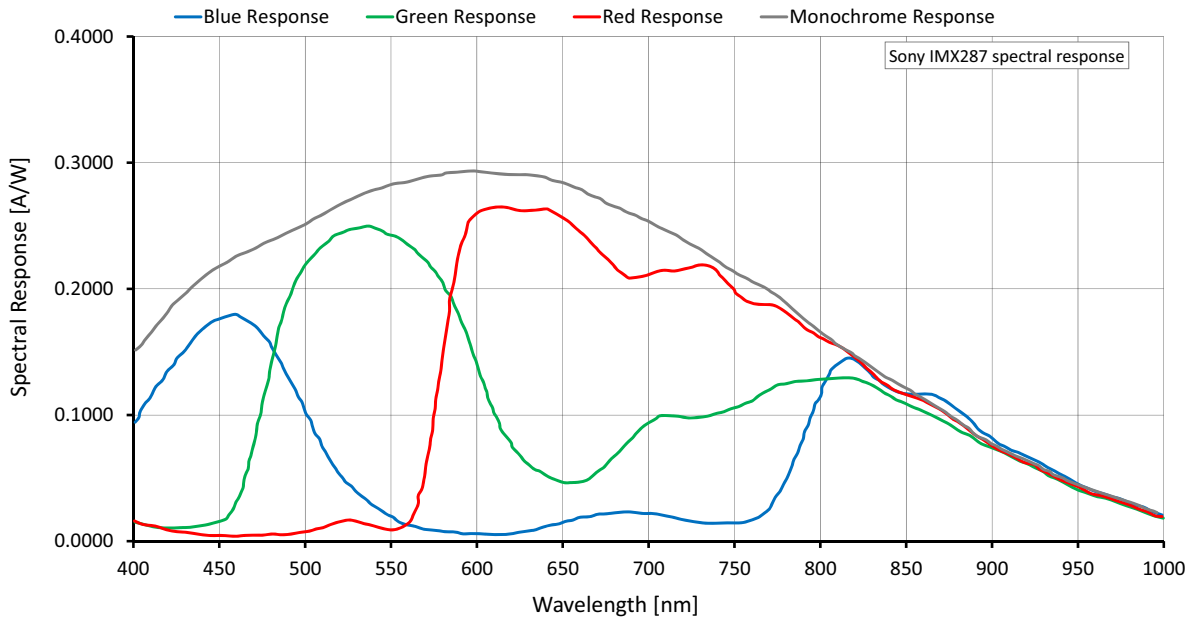

Figure 5: Alvium G1-040m/c (Sony IMX287) spectral response

## ROI frame rates

Values are based on the conditions defined in [Specified values](#) on page 46.

Image format	Width [pixels]	Height [pixels]	ROI area [MP]	Frame rate [fps] <sup>1</sup>	
				122 MByte/s	12 MByte/s
Full resolution	728	544	0.396	276.4/139.3/138.6	27.9/14.0/14.0
VGA	640	480	0.307	349.4/176.9/176.6	35.5/17.9/17.8
HVGA	480	320	0.154	615.0/335.7/332.3	62.9/34.1/34.0
QVGA	320	240	0.077	778.0/638.8/617.7	80.1/65.1/65.0
HQVGA	240	160	0.038	1058.4/1059.4/847.2	110.3/110.6/110.3
QQVGA	160	120	0.019	1291.0/1296.2/1037.6	135.8/136.3/136.0
Max. × half	728	272	0.198	502.1/254.2/252.6	51.3/25.8/25.7
Max. × min.	728	8	0.006	2423.5/1271.1/1247.9	277.4/139.5/139.2
Min. × max.	8	544	0.004	387.7/385.4/306.8	39.3/39.3/39.2
Min. × min.	8	8	64 P	3356.6/3463.1/2798.4	385.1/390.9/389.8

<sup>1</sup> Mono8 or Bayer...8<sup>(2)</sup> at **SensorBitDepth** = 8-Bit<sup>(3)</sup> / Mono10 or Bayer...10 at **SensorBitDepth** = 10-Bit / Mono12 or Bayer...12 at **SensorBitDepth** = 12-Bit

<sup>2</sup> The three dots... represent the colors of a Bayer pixel format, such as in Bayer**RG8**.

<sup>3</sup> The **SensorBitDepth** value must be set separately from **PixelFormat**. See [Sensor ADC readout modes for maximum frame rates](#) on page 47 for details.

Table 17: Alvium G1-040m/c ROI frame rates



## Alvium G1-130 VSWIR

Feature	Specification
	<b>G1-130 VSWIR</b>
Sensor model	Sony IMX990
Resolution	1296 (H) × 1032 (V); 1.3 MP
Sensor type	InGaAs
Shutter type	Global shutter (GS)
Sensor size	Type 1/2; 6.4 mm × 5.12 mm; 8.2 mm diagonal
Pixel size	5 μm × 5 μm
CRA	0 deg
Sensor bit depth (ADC)	8-bit, 10-bit, 12-bit; Adaptive (10-bit, 12-bit)
Monochrome pixel formats	Mono8 (default), Mono10, Mono10p, Mono12, Mono12p   Mono8, Mono10, Mono10p, Mono12, Mono12p
Maximum frame rate	86 fps (at 122 MByte/s)
Exposure time	30 μs to 10 s (at 122 MByte/s)
Exposure modes	Timed, TriggerControlled, TriggerWidth
Gain	0 dB to 42 dB; 0.1 dB increments
Digital binning	Horizontal: 1 to 8 columns; Vertical: 1 to 8 rows
Multiple ROI (H × V)	<i>Free   Tile   Horizontal</i> : 1 × 1 to 1 × 4   <i>Vertical</i> : 1 × 1 to 4 × 1
Image buffer (RAM)	32 MByte
Non-volatile memory (Flash)	1024 KByte
Inputs and outputs	1 opto-isolated input, 1 opto-isolated output, 2 non-isolated GPIOs <sup>1</sup>
Power requirements	12 to 24 VDC
Power requirements (PoE)	IEEE 802.3af
Power consumption (typical)	External power: 2.9 W at 12 VDC Power over Ethernet: 3.2 W
Storage temperature	-20 °C to +85 °C ambient temperature
Operating temperature	-20 °C to +55 °C (Housing, typical), -20 °C to +85 °C (Mainboard <sup>2</sup> )
Humidity	0% to 80% humidity (non-condensing)
Digital interface	1000BASE-T
Camera controls	GenICam (GenICam Access)
<sup>1</sup> Use with external power only, not with PoE. See <a href="#">I/Os and power supply by PoE</a> on page 38. <sup>2</sup> Output by DeviceTemperature	

Table 18: Alvium G1-130 VSWIR specifications

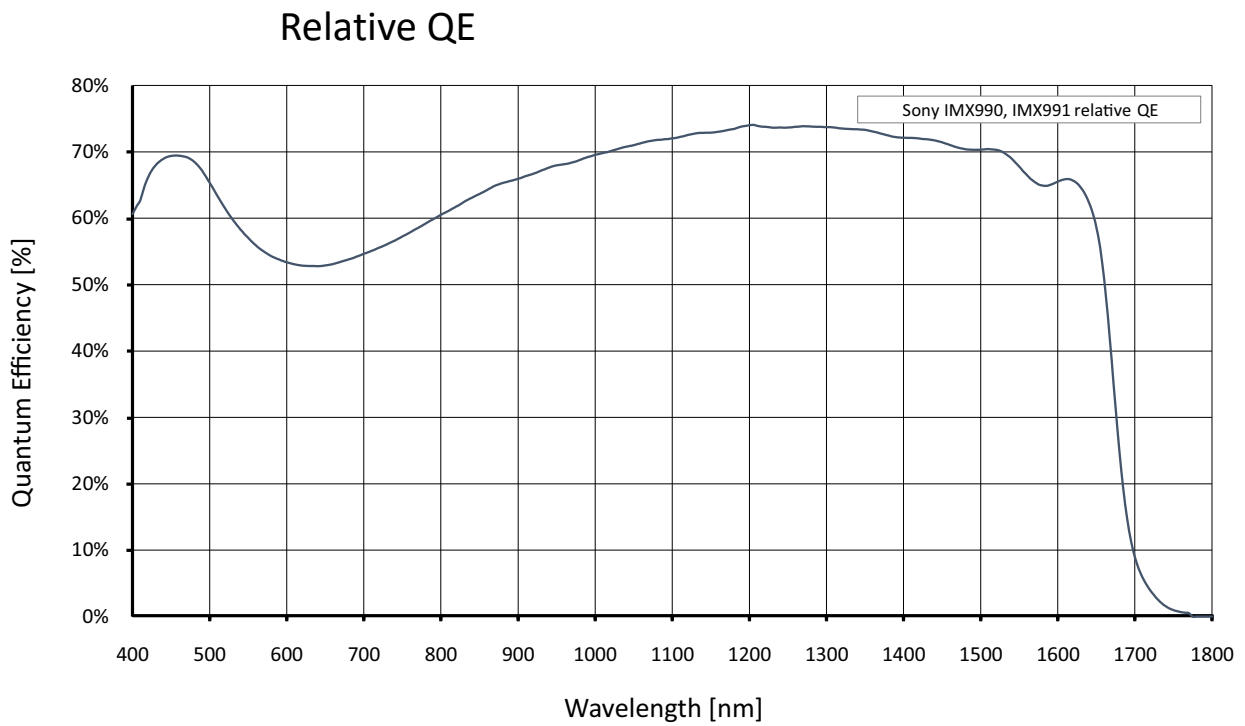

Figure 6: Alvium G1-130 VSWIR (Sony IMX990) relative QE

## ROI frame rates

Values are based on the conditions defined in [Specified values](#) on page 46.

Image format	Width [pixels]	Height [pixels]	ROI area [MP]	Frame rate [fps] <sup>1</sup>	
				122 MByte/s	12 MByte/s
Full resolution	1296	1032	1.337	86.3 / 43.3 / 43.4	8.6 / 4.3 / 4.3
SXGA	1280	1024	1.311	88.3 / 44.2 / 44.2	8.8 / 4.4 / 4.4
HD 720	1280	720	0.922	122.9 / 61.7 / 61.6	12.3 / 6.2 / 6.2
XGA	1024	768	0.786	144.5 / 72.5 / 72.5	14.5 / 7.3 / 7.2
SVGA	800	600	0.480	218.3 / 116.9 / 116.4	23.4 / 11.8 / 11.7
VGA	640	480	0.307	268.4 / 179.2 / 142.9	36.0 / 18.1 / 18.0
HVGA	480	320	0.154	384.8 / 342.1 / 205.1	69.0 / 34.7 / 34.6
QVGA	320	240	0.077	494.0 / 457.2 / 262.7	132.4 / 66.5 / 66.4
HQVGA	240	160	0.038	686.4 / 634.4 / 365.0	243.6 / 123.2 / 122.8
QQVGA	160	120	0.019	849.9 / 789.2 / 454.6	453.6 / 229.3 / 228.6
Max. x half	1296	516	0.669	163.3 / 82.3 / 82.2	16.5 / 8.3 / 8.2
Max. x min.	1296	8	0.010	1512.1 / 796.5 / 784.2	173.1 / 87.1 / 86.9
Min. x max.	8	1032	0.008	132.4 / 123.0 / 70.4	
Min. x min.	8	8	64 P	2644.2 / 2455.3 / 1405.9	

<sup>1</sup> Mono8 at SensorBitDepth = 8-Bit<sup>(2)</sup> / Mono10 at SensorBitDepth = 10-Bit / Mono12 or at SensorBitDepth = 12-Bit

<sup>2</sup> The SensorBitDepth value must be set separately from PixelFormat. See [Sensor ADC readout modes for maximum frame rates](#) on page 47 for details.

Table 19: Alvium G1-130 VSWIR ROI frame rates

## Alvium G1-158m/c

Feature	Specification	
	G1-158m (monochrome)	G1-158c (color)
Sensor model	Sony IMX273	
Resolution	1456 (H) × 1088 (V); 1.6 MP	
Sensor type	CMOS	
Shutter type	Global shutter (GS)	
Sensor size	Type 1/2.9; 5 mm × 3.8 mm; 6.3 mm diagonal	
Pixel size	3.45 μm × 3.45 μm	
CRA	0 deg	
Sensor bit depth (ADC)	8-bit, 10-bit, 12-bit; Adaptive (10-bit, 12-bit)	
Monochrome pixel formats	Mono8 (default), Mono10, Mono10p, Mono12, Mono12p	Mono8, Mono10, Mono10p, Mono12, Mono12p
YUV color pixel formats	Not applicable	YCbCr411_8_CbYYCrYY, YCbCr422_8_CbYCrY, YCbCr8_CbYCr
RGB color pixel formats	Not applicable	BayerRG8, BayerRG10, BayerRG10p, BayerRG12, BayerRG12p, BGR8, RGB8 (default)
Maximum frame rate	72 fps (at 122 MByte/s)	
Exposure time	39 μs to 10 s (at 122 MByte/s)	
Exposure modes	Timed, TriggerControlled, TriggerWidth	
Gain	0 dB to 48 dB; 0.1 dB increments	
Digital binning	Horizontal: 1 to 8 columns; Vertical: 1 to 8 rows	
Multiple ROI (H × V)	<i>Free   Tile</i>	
Image buffer (RAM)	32 MByte	
Non-volatile memory (Flash)	1024 KByte	
Inputs and outputs	1 opto-isolated input, 1 opto-isolated output, 2 non-isolated GPIOs <sup>1</sup>	
Power requirements	12 to 24 VDC	
Power requirements (PoE)	IEEE 802.3af	
Power consumption (typical)	External power: 3.6 W at 12 VDC Power over Ethernet: 3.9 W	
Storage temperature	-20 °C to +85 °C ambient temperature	
Operating temperature	-20 °C to +50 °C (Housing, typical), -20 °C to +85 °C (Mainboard <sup>2</sup> )	
Humidity	0% to 80% humidity (non-condensing)	
Digital interface	1000BASE-T	
Camera controls	GenICam (GenICam Access)	

<sup>1</sup> Use with external power only, not with PoE. See [I/Os and power supply by PoE](#) on page 38.

<sup>2</sup> Output by DeviceTemperature

Table 20: Alvium G1-158m/c specifications

### Absolute QE

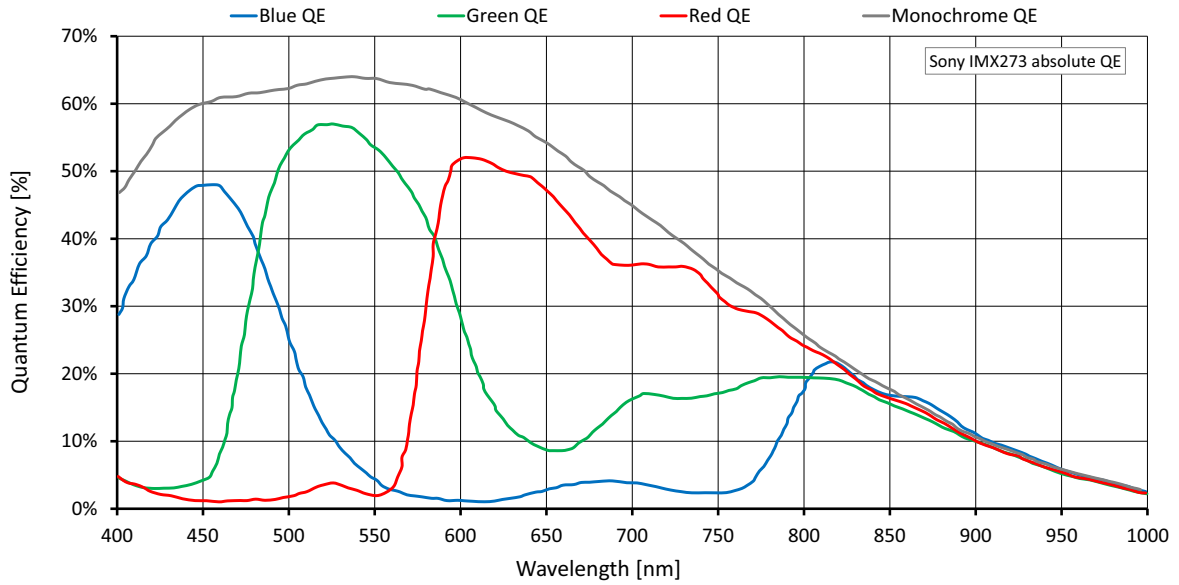

Figure 7: Alvium G1-158m/c (Sony IMX273) absolute QE

### Spectral response

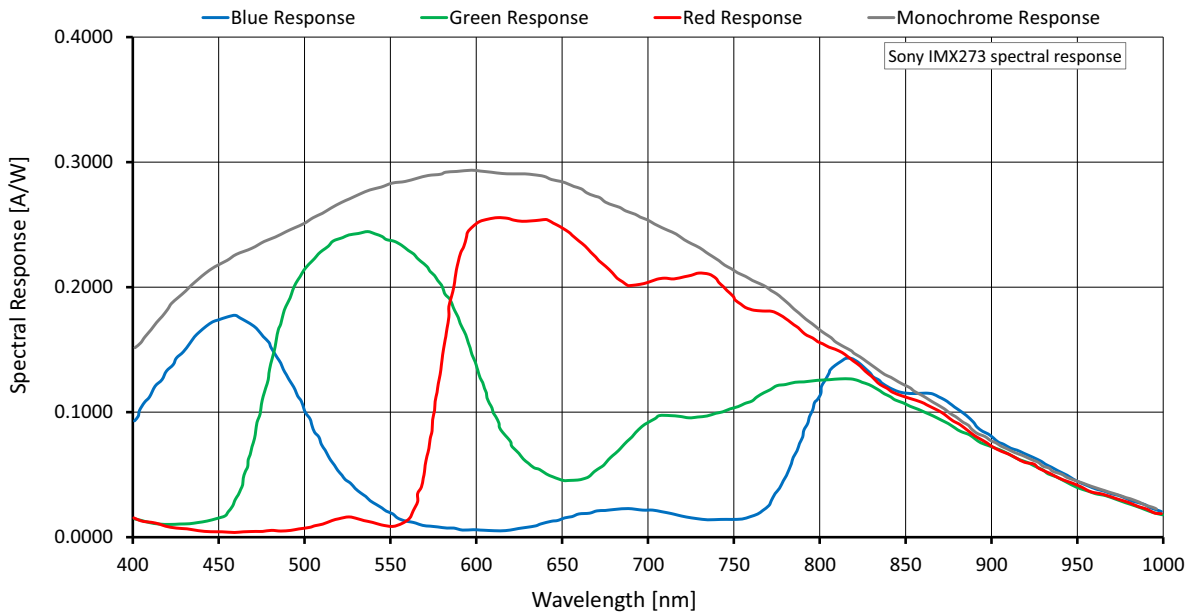

Figure 8: Alvium G1-158m/c (Sony IMX273) spectral response

## ROI frame rates

Values are based on the conditions defined in [Specified values](#) on page 46.

Image format	Width [pixels]	Height [pixels]	ROI area [MP]	Frame rate [fps] <sup>1</sup>	
				122 MByte/s	12 MByte/s
Full resolution	1456	1088	1.584	72.7/36.6/36.5	7.2/3.6/3.6
WXGA+	1440	900	1.296	88.1/44.2/44.1	8.8/4.4/4.4
SXGA	1280	1024	1.311	87.6/43.9/43.9	8.7/4.4/4.4
HD 720	1280	720	0.922	121.7/61.1/61.0	12.2/6.1/6.1
XGA	1024	768	0.786	143.3/72.2/71.9	14.4/7.2/7.2
SVGA	800	600	0.480	229.8/115.5/115.0	23.2/11.6/11.6
VGA	640	480	0.307	348.8/176.6/176.2	35.5/17.9/17.8
HVGA	480	320	0.154	613.4/334.8/332.2	62.9/34.1/34.0
QVGA	320	240	0.077	775.4/636.7/615.6	80.1/65.1/65.0
HQVGA	240	160	0.038	1058.3/1059.4/843.3	110.3/110.6/110.3
QQVGA	160	120	0.019	1291.0/1296.2/1031.8	135.8/136.3/136.0
Max. × half	1456	544	0.792	137.9/69.6/69.4	13.9/7.0/7.0
Max. × min.	1456	8	0.012	1194.4/635.5/626.0	136.4/69.8/69.6
Min. × max.	8	1088	0.009	204.3/202.2/161.0	20.5/20.5/20.5
Min. × min.	8	8	64 P	3356.6/3463.1/2756.6	385.1/390.9/389.8

<sup>1</sup> Mono8 or Bayer...8<sup>(2)</sup> at **SensorBitDepth** = 8-Bit<sup>(3)</sup> /  
 Mono10 or Bayer...10 at **SensorBitDepth** = 10-Bit /  
 Mono12 or Bayer...12 at **SensorBitDepth** = 12-Bit

<sup>2</sup> The three dots... represent the colors of a Bayer pixel format, such as in Bayer**RG8**.

<sup>3</sup> The **SensorBitDepth** value must be set separately from **PixelFormat**.  
 See [Sensor ADC readout modes for maximum frame rates](#) on page 47 for details.

Table 21: Alvium G1-158m/c ROI frame rates

## Alvium G1-234m/c

Feature	Specification	
	G1-234m	G1-234c
Sensor model	Sony IMX249	
Resolution	1936 (H) × 1216 (V); 2.35 MP	
Sensor type	CMOS	
Shutter type	Global shutter (GS)	
Sensor size	Type 1/1.2; 11.3 mm × 7.1 mm; 13.4 mm diagonal	
Pixel size	5.86 μm × 5.86 μm	
CRA	0 deg	
Sensor bit depth (ADC)	10-bit, 12-bit; Adaptive (10-bit, 12-bit)	
Monochrome pixel formats	Mono8 (default), Mono10, Mono10p, Mono12, Mono12p	Mono8, Mono10, Mono10p, Mono12, Mono12p
YUV color pixel formats	Not applicable	YCbCr411_8_CbYYCrYY, YCbCr422_8_CbYCrY, YCbCr8_CbYCr
RGB color pixel formats	Not applicable	BayerRG8, BayerRG10, BayerRG10p, BayerRG12, BayerRG12p, BGR8, RGB8 (default)
Maximum frame rate	40 fps (at ≥99 MByte/s)	
Exposure time	53 μs to 10 s (at 99 MByte/s)	
Exposure modes	Timed	
Gain	0 dB to 48 dB; 0.1 dB increments	
Digital binning	Horizontal: 1 to 8 columns; Vertical: 1 to 8 rows	
Multiple ROI (H × V)	<i>Free</i>	
Image buffer (RAM)	32 MByte	
Non-volatile memory (Flash)	1024 KByte	
Inputs and outputs	1 opto-isolated input, 1 opto-isolated output, 2 non-isolated GPIOs <sup>1</sup>	
Power requirements	12 to 24 VDC	
Power requirements (PoE)	IEEE 802.3af	
Power consumption (typical)	External power: 3.0 W at 12 VDC Power over Ethernet: 3.3 W	
Storage temperature	-20 °C to +85 °C ambient temperature	
Operating temperature	-20 °C to +55 °C (Housing, typical), -20 °C to +85 °C (Mainboard <sup>2</sup> )	
Humidity	0% to 80% humidity (non-condensing)	
Digital interface	1000BASE-T	
Camera controls	GenICam (GenICam Access)	

<sup>1</sup> Use with external power only, not with PoE. See [I/Os and power supply by PoE](#) on page 38.

<sup>2</sup> Output by `DeviceTemperature`

Table 22: Alvium G1-234m/c specifications

### Absolute QE

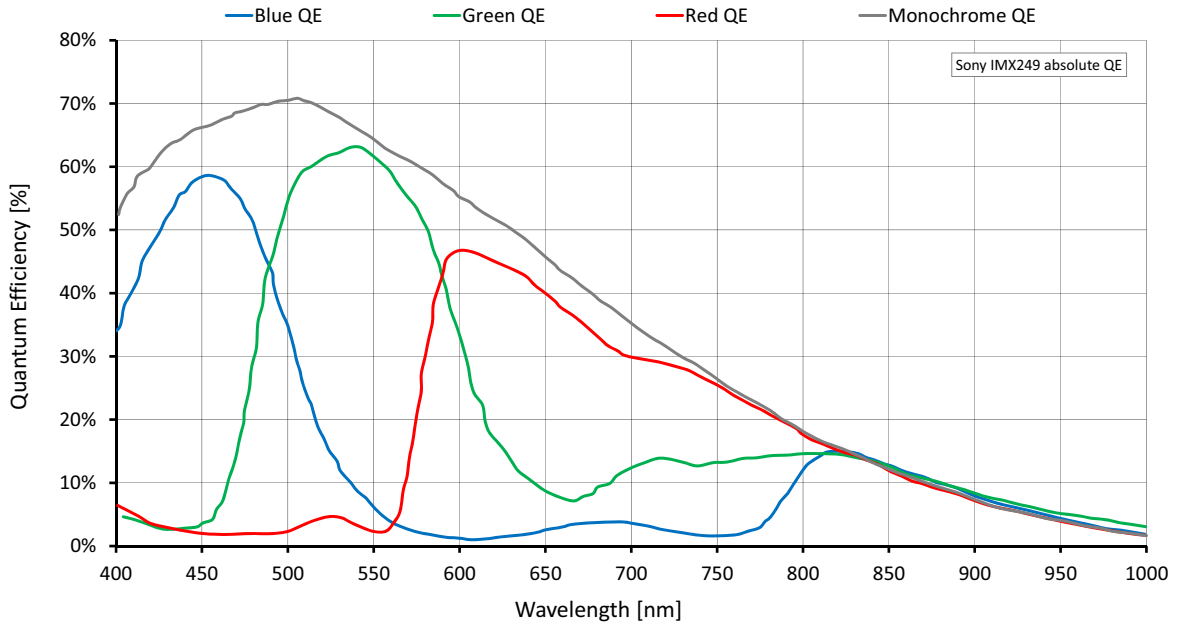

Figure 9: Alvim G1-234m/c (Sony IMX249) absolute QE

### Spectral response

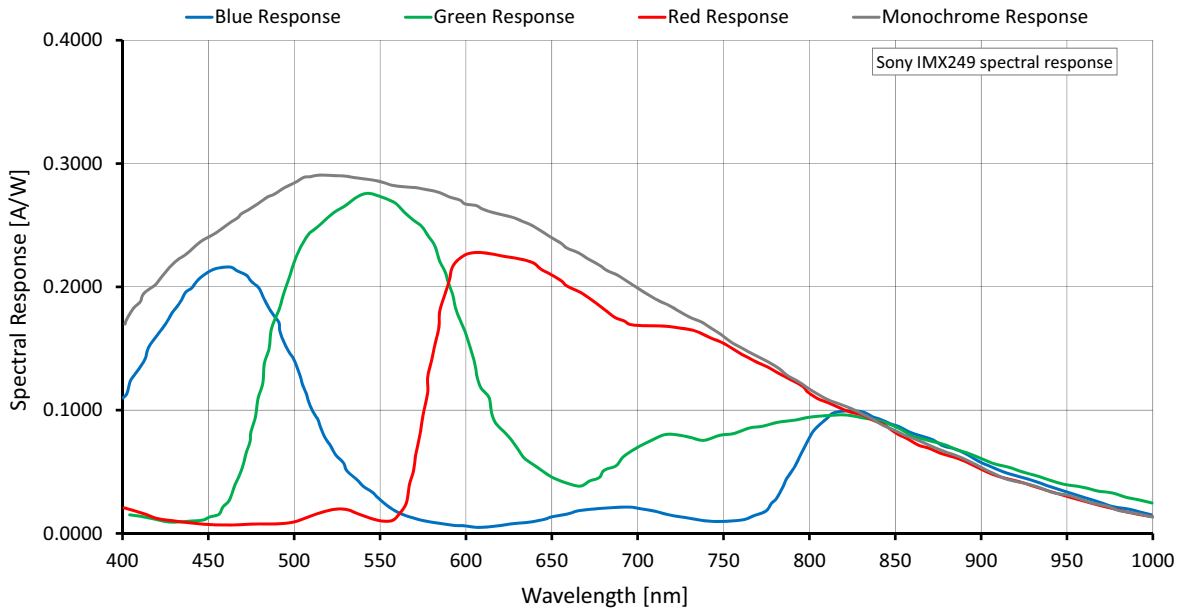

Figure 10: Alvim G1-234m/c (Sony IMX249) spectral response



## ROI frame rates

Values are based on the conditions defined in [Specified values](#) on page 46. To reach the maximum frame rate available for typical operation, the bandwidth for image traffic is 99 MByte/s. Increasing the `DeviceLinkThroughputLimit` value does not increase frame rates.

Image format	Width [pixels]	Height [pixels]	ROI area [MP]	Frame rate [fps] <sup>1</sup>	
				122 MByte/s	12 MByte/s
Full resolution	1936	1216	2,354	40.4/24.8	4.9/2.4
Full HD	1920	1080	2,074	45.3/28.0	5.5/2.8
UXGA	1600	1200	1,920	41.0/30.4	6.0/3.0
WXGA+	1440	900	1,296	53.9/42.0	8.8/4.4
SXGA	1280	1024	1,311	47.7/37.2	8.8/4.4
HD 720	1280	720	0.922	66.5/51.8	12.3/6.2
XGA	1024	768	0.786	62.7/48.8	14.4/7.2
SVGA	800	600	0.480	79.0/61.6	23.3/11.7
VGA	640	480	0.307	96.9/75.5	35.7/18.0
HVGA	480	320	0.154	139.2/108.5	68.3/34.4
QVGA	320	240	0.077	177.7/138.5	131.2/66.0
HQVGA	240	160	0.038	245.8/191.6	240.8/121.6
QQVGA	160	120	0.019	305.8/238.3	305.8/225.9
Max. × half	1936	608	1,177	77.6/47.7	9.5/4.7
Max. × min.	1936	8	0.015	828.7/524.8	111.6/56.1
Min. × max.	8	1216	0.010	40.6/40.6/31.6	
Min. × min.	8	8	64 P	917.5/917.5/715.1	

<sup>1</sup> Mono8 or Mono10, or Bayer...8<sup>(2)</sup> or Bayer...10 at `SensorBitDepth` = 10-Bit<sup>(3)</sup> / Mono12 or Bayer...12 at `SensorBitDepth` = 12-Bit

<sup>2</sup> The three dots... represent the colors of a Bayer pixel format, such as in BayerRG8.

<sup>3</sup> The `SensorBitDepth` value must be set separately from `PixelFormat`. See [Sensor ADC readout modes for maximum frame rates](#) on page 47 for details.

Table 23: Alvium G1-234m/c ROI frame rates

## Alvium G1-240m/c

Feature	Specification	
	G1-240m (monochrome)	G1-240c (color)
Sensor model	Sony IMX392	
Resolution	1936 (H) × 1216 (V); 2.4 MP	
Sensor type	CMOS	
Shutter type	Global shutter (GS)	
Sensor size	Type 1/2.3; 6.7 mm × 4.2 mm; 7.9 mm diagonal	
Pixel size	3.45 μm × 3.45 μm	
CRA	0 deg	
Sensor bit depth (ADC)	8-bit, 10-bit, 12-bit; Adaptive (10-bit, 12-bit)	
Monochrome pixel formats	Mono8 (default), Mono10, Mono10p, Mono12, Mono12p	Mono8, Mono10, Mono10p, Mono12, Mono12p
YUV color pixel formats	Not applicable	YCbCr411_8_CbYYCrYY, YCbCr422_8_CbYCrY, YCbCr8_CbYCr
RGB color pixel formats	Not applicable	BayerRG8, BayerRG10, BayerRG10p, BayerRG12, BayerRG12p, BGR8, RGB8 (default)
Maximum frame rate	49 fps (at 122 MByte/s)	
Exposure time	46 μs to 10 s (at 122 MByte/s)	
Exposure modes	Timed, TriggerControlled, TriggerWidth	
Gain	0 dB to 48 dB; 0.1 dB increments	
Digital binning	Horizontal: 1 to 8 columns; Vertical: 1 to 8 rows	
Multiple ROI (H × V)	<i>Free   Tile</i>	
Image buffer (RAM)	32 MByte	
Non-volatile memory (Flash)	1024 KByte	
Inputs and outputs	1 opto-isolated input, 1 opto-isolated output, 2 non-isolated GPIOs <sup>1</sup>	
Power requirements	12 to 24 VDC	
Power requirements (PoE)	IEEE 802.3af	
Power consumption (typical)	External power: 3.6 W at 12 VDC Power over Ethernet: 4.0 W	
Storage temperature	-20 °C to +85 °C ambient temperature	
Operating temperature	-20 °C to +50 °C (Housing, typical), -20 °C to +85 °C (Mainboard <sup>2</sup> )	
Humidity	0% to 80% humidity (non-condensing)	
Digital interface	1000BASE-T	
Camera controls	GenICam (GenICam Access)	

<sup>1</sup> Use with external power only, not with PoE. See [I/Os and power supply by PoE](#) on page 38.

<sup>2</sup> Output by DeviceTemperature

Table 24: Alvium G1-240m/c specifications

### Absolute QE

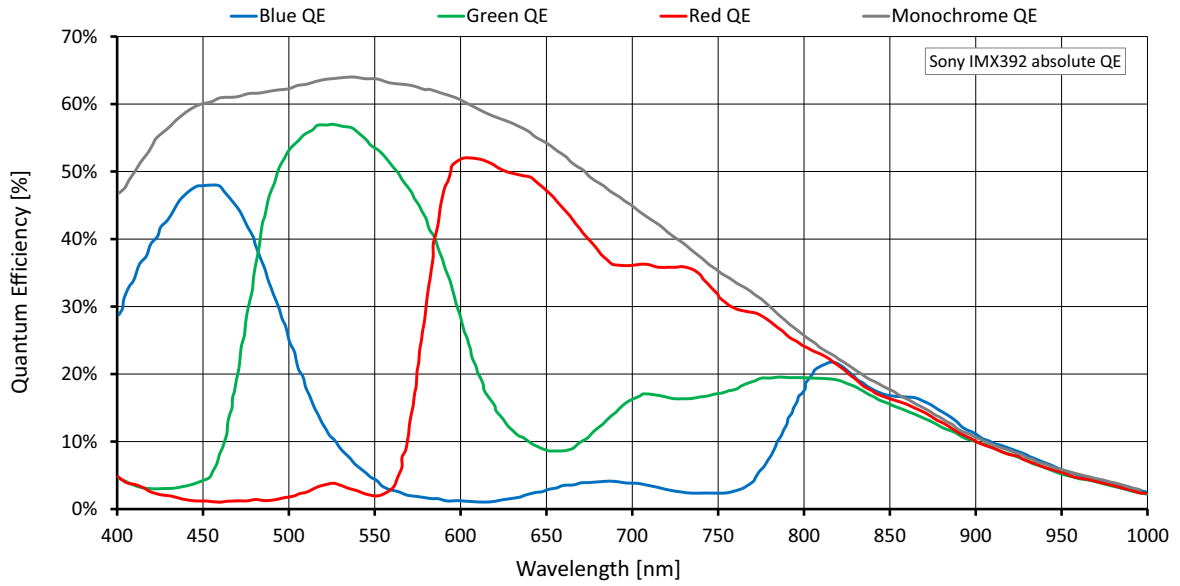

Figure 11: Alvium G1-240m/c (Sony IMX392) absolute QE

### Spectral response

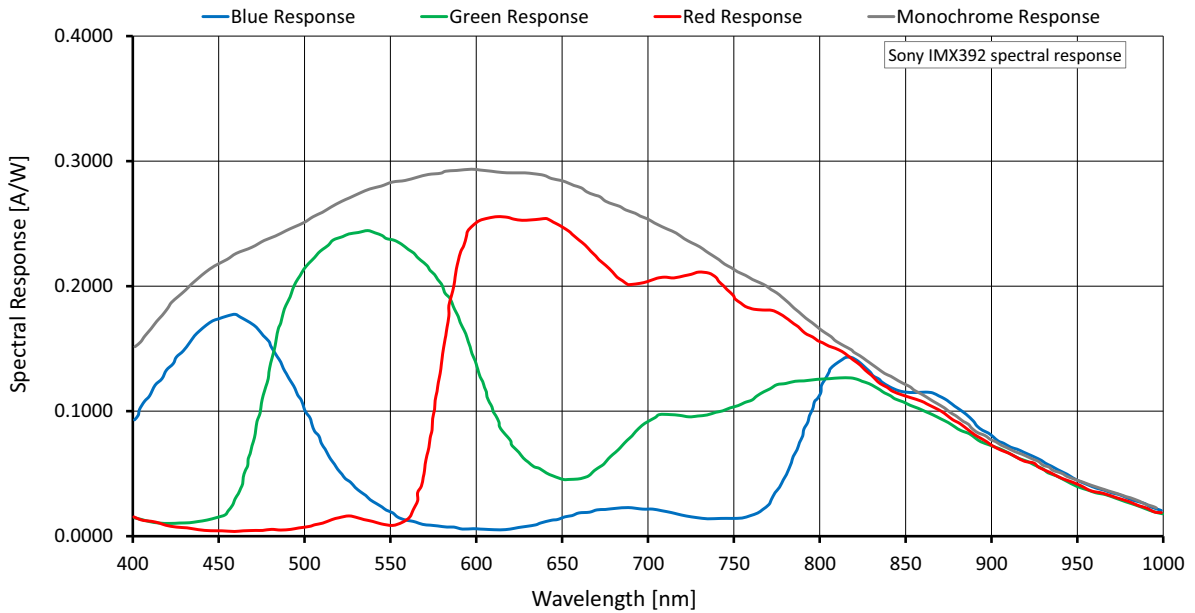

Figure 12: Alvium G1-240m/c (Sony IMX392) spectral response

## ROI frame rates

Values are based on the conditions defined in [Specified values](#) on page 46.

Image format	Width [pixels]	Height [pixels]	ROI area [MP]	Frame rate [fps] <sup>1</sup>	
				122 MByte/s	12 MByte/s
Full resolution	1936	1216	2.354	49.3/24.8/24.8	4.9/2.9/2.4
Full HD	1920	1080	2.074	55.8/28.0/28.1	5.5/3.3/2.8
UXGA	1600	1200	1.920	60.4/30.4/30.4	6.0/3.6/3.0
WXGA+	1440	900	1.296	88.4/44.5/44.5	8.8/5.3/4.4
SXGA	1280	1024	1.311	87.9/44.2/44.2	8.8/5.3/4.4
HD 720	1280	720	0.922	122.3/61.6/61.6	12.3/7.4/6.2
XGA	1024	768	0.786	144.0/72.7/72.6	14.4/8.7/7.3
SVGA	800	600	0.480	231.2/116.6/116.4	23.3/14.1/11.8
VGA	640	480	0.307	351.4/178.5/178.9	35.8/21.6/18.1
HVGA	480	320	0.154	619.9/340.2/339.4	63.6/41.5/34.7
QVGA	320	240	0.077	785.8/649.7/574.6	81.3/79.7/66.9
HQVGA	240	160	0.038	1077.8/972.8/796.3	112.4/136.2/114.6
QQVGA	160	120	0.019	1320.0/1199.1/983.6	139.0/169.1/142.6
Max. x half	1936	608	1.177	94.4/47.7/47.7	9.5/5.7/4.8
Max. x min.	1936	8	0.015	953.3/525.4/533.6	109.8/69.8/60.4
Min. x max.	8	1216	0.010	184.2/162.6/132.0	18.5/22.2/18.5
Min. x min.	8	8	64 P	3560.0/3437.4/2883.2	412.2/519.8/449.8

<sup>1</sup> Mono8 or Bayer...8<sup>(2)</sup> at SensorBitDepth = 8-Bit<sup>(3)</sup> /  
 Mono10 or Bayer...10 at SensorBitDepth = 10-Bit /  
 Mono12 or Bayer...12 at SensorBitDepth = 12-Bit

<sup>2</sup> The three dots... represent the colors of a Bayer pixel format, such as in BayerRG8.

<sup>3</sup> The SensorBitDepth value must be set separately from PixelFormat.

See [Sensor ADC readout modes for maximum frame rates](#) on page 47 for details.

Table 25: Alvium G1-240m/c ROI frame rates

## Alvium G1-319m/c

Feature	Specification	
	G1-319m (monochrome)	G1-319c (color)
Sensor model	Sony IMX265	
Resolution	2064 (H) × 1544 (V); 3.2 MP	
Sensor type	CMOS	
Shutter type	Global shutter (GS)	
Sensor size	Type 1/1.8; 7.1 mm × 5.3 mm; 8.9 mm diagonal	
Pixel size	3.45 μm × 3.45 μm	
CRA	0 deg	
Sensor bit depth (ADC)	12-bit	
Monochrome pixel formats	Mono8 (default), Mono10, Mono10p, Mono12, Mono12p	Mono8, Mono10, Mono10p, Mono12, Mono12p
YUV color pixel formats	Not applicable	YCbCr411_8_CbYYCrYY, YCbCr422_8_CbYCrY, YCbCr8_CbYCr
RGB color pixel formats	Not applicable	BayerRG8, BayerRG10, BayerRG10p, BayerRG12, BayerRG12p, BGR8, RGB8 (default)
Maximum frame rate	36 fps (at 122 MByte/s)	
Exposure time	49 μs to 10 s (at 122 MByte/s)	
Exposure modes	Timed, TriggerControlled, TriggerWidth	
Gain	0 dB to 48 dB; 0.1 dB increments	
Digital binning	Horizontal: 1 to 8 columns; Vertical: 1 to 8 rows	
Multiple ROI (H × V)	<i>Free</i>	
Image buffer (RAM)	32 MByte	
Non-volatile memory (Flash)	1024 KByte	
Inputs and outputs	1 opto-isolated input, 1 opto-isolated output, 2 non-isolated GPIOs <sup>1</sup>	
Power requirements	12 to 24 VDC	
Power requirements (PoE)	IEEE 802.3af	
Power consumption (typical)	External power: 3.0 W at 12 VDC Power over Ethernet: 3.3 W	
Storage temperature	-20 °C to +85 °C ambient temperature	
Operating temperature	-20 °C to +55 °C (Housing, typical), -20 °C to +85 °C (Mainboard <sup>2</sup> )	
Humidity	0% to 80% humidity (non-condensing)	
Digital interface	1000BASE-T	
Camera controls	GenICam (GenICam Access)	

<sup>1</sup> Use with external power only, not with PoE. See [I/Os and power supply by PoE](#) on page 38.

<sup>2</sup> Output by DeviceTemperature

Table 26: Alvium G1-319m/c specifications

### Absolute QE

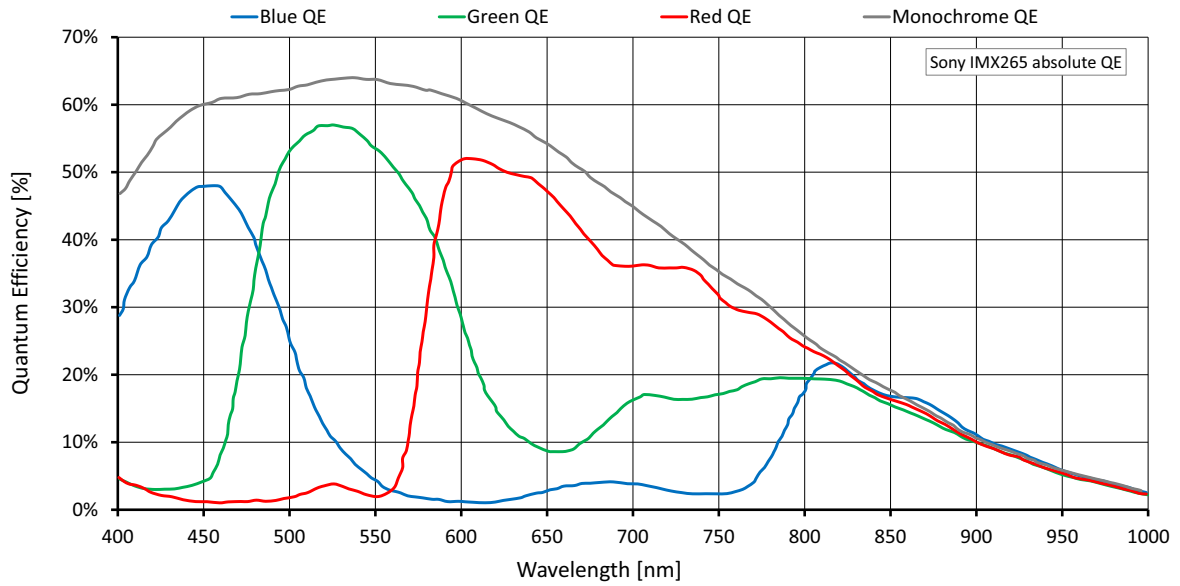

Figure 13: Alvium G1-319m/c (Sony IMX265) absolute QE

### Spectral response

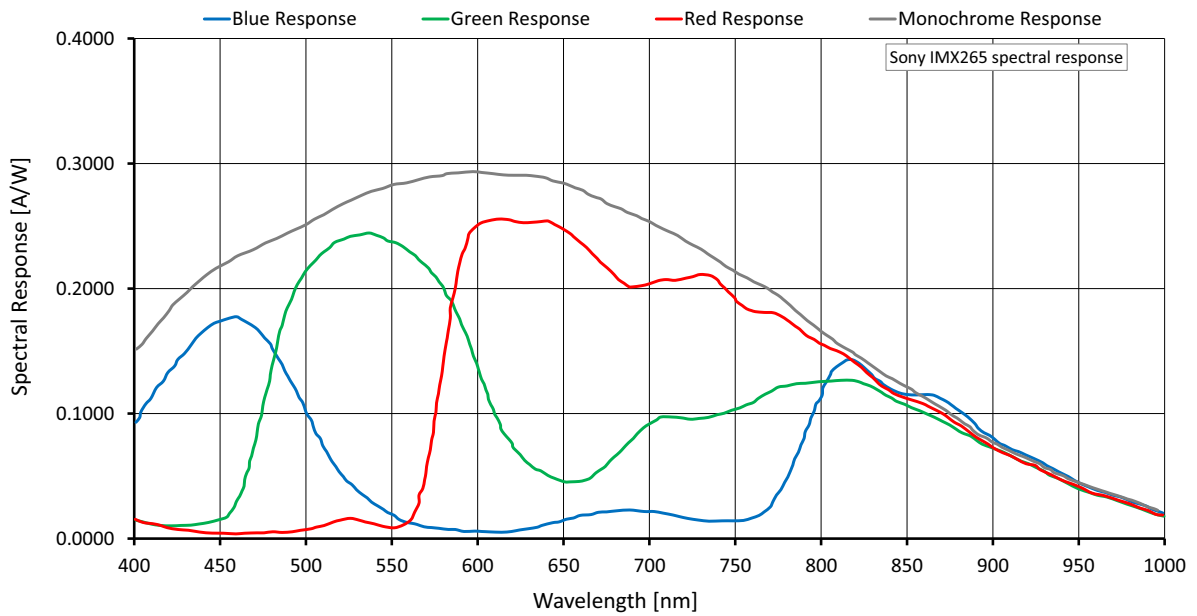

Figure 14: Alvium G1-319m/c (Sony IMX265) spectral response

## ROI frame rates

Values are based on the conditions defined in [Specified values](#) on page 46.

Image format	Width [pixels]	Height [pixels]	ROI area [MP]	Frame rate [fps] <sup>1</sup>	
				122 MByte/s	12 MByte/s
Full resolution	2064	1544	3.187	36.7/18.4	3.6/1.8
QXGA	2048	1536	3.146	37.3/18.7	3.7/1.8
Full HD	1920	1080	2.074	55.6/28.0	5.5/2.8
UXGA	1600	1200	1.920	60.3/30.3	6.0/3.0
WXGA+	1440	900	1.296	88.2/44.4	8.8/4.4
SXGA	1280	1024	1.311	80.5/44.1	8.8/4.4
HD 720	1280	720	0.922	112.0/61.5	12.3/6.2
XGA	1024	768	0.786	105.7/72.4	14.4/7.2
SVGA	800	600	0.480	133.2/116.2	23.3/11.7
VGA	640	480	0.307	163.8/163.5	35.7/18.0
HVGA	480	320	0.154	234.8/234.8	68.5/34.6
QVGA	320	240	0.077	301.5/301.5	131.4/66.4
HQVGA	240	160	0.038	416.9/416.9	223.9/113.5
QQVGA	160	120	0.019	515.6/515.6	277.5/140.9
Max. × half	2064	772	1.593	70.9/35.7	7.1/3.6
Max. × min.	2064	8	0.017	879.5/484.1	106.4/54.5
Min. × max.	8	1544	0.012	54.7/54.7	29.1/14.7
Min. × min.	8	8	64 P	1556.1/1528.8	842.6/433.2

<sup>1</sup> Mono8 or Bayer...8<sup>(2)</sup> at `SensorBitDepth` = 12-Bit / Mono12 or Bayer...12 at `SensorBitDepth` = 12-Bit

<sup>2</sup> The three dots... represent the colors of a Bayer pixel format, such as in BayerRG8.

Table 27: Alvium G1-319m/c ROI frame rates

## Alvium G1-500m/c

Feature	Specification	
	G1-500m	G1-500c
Sensor model	ON Semiconductor AR0521SR	
Resolution	2592 (H) × 1944 (V); 5.0 MP	
Sensor type	CMOS	
Shutter type	Rolling shutter (RS)	
Sensor size	Type 1/2.5; 5.7 mm × 4.3 mm; 7.1 mm diagonal	
Pixel size	2.2 μm × 2.2 μm	
CRA	9 deg	
Sensor bit depth (ADC)	10-bit	
Monochrome pixel formats	Mono8 (default), Mono10, Mono10p	Mono8, Mono10, Mono10p
YUV color pixel formats	Not applicable	YCbCr411_8_CbYYCrYY, YCbCr422_8_CbYCrY, YCbCr8_CbYCr
RGB color pixel formats	Not applicable	BayerGR8, BayerGR10, BayerGR10p, BGR8, RGB8 (default)
Maximum frame rate	23 fps (at 122 MByte/s)	
Exposure time	22 μs to 1.4 s (at 122 MByte/s)	
Exposure modes	Timed	
Gain	0 dB to 24.1 dB; 0.1 dB increments	
Digital binning	Horizontal: 1 to 8 columns; Vertical: 1 to 8 rows	
Sensor binning (H × V)	2 × 1, 4 × 1	
Image buffer (RAM)	32 MByte	
Non-volatile memory (Flash)	1024 KByte	
Inputs and outputs	1 opto-isolated input, 1 opto-isolated output, 2 non-isolated GPIOs <sup>2</sup>	
Power requirements	12 to 24 VDC	
Power requirements (PoE)	IEEE 802.3af	
Power consumption (typical)	External power: 2.9 W at 12 VDC Power over Ethernet: 3.2 W	
Storage temperature	-20 °C to +85 °C ambient temperature	
Operating temperature	-20 °C to +55 °C (Housing, typical), -20 °C to +85 °C (Mainboard <sup>3</sup> )	
Humidity	0% to 80% humidity (non-condensing)	
Digital interface	1000BASE-T	
Camera controls	GenICam (GenICam Access)	
<sup>1</sup> In triggered mode: 11 fps <sup>2</sup> Use with external power only, not with PoE. See <a href="#">I/Os and power supply by PoE</a> on page 38. <sup>3</sup> Output by DeviceTemperature		

Table 28: Alvium G1-500m/c specifications



### Absolute QE

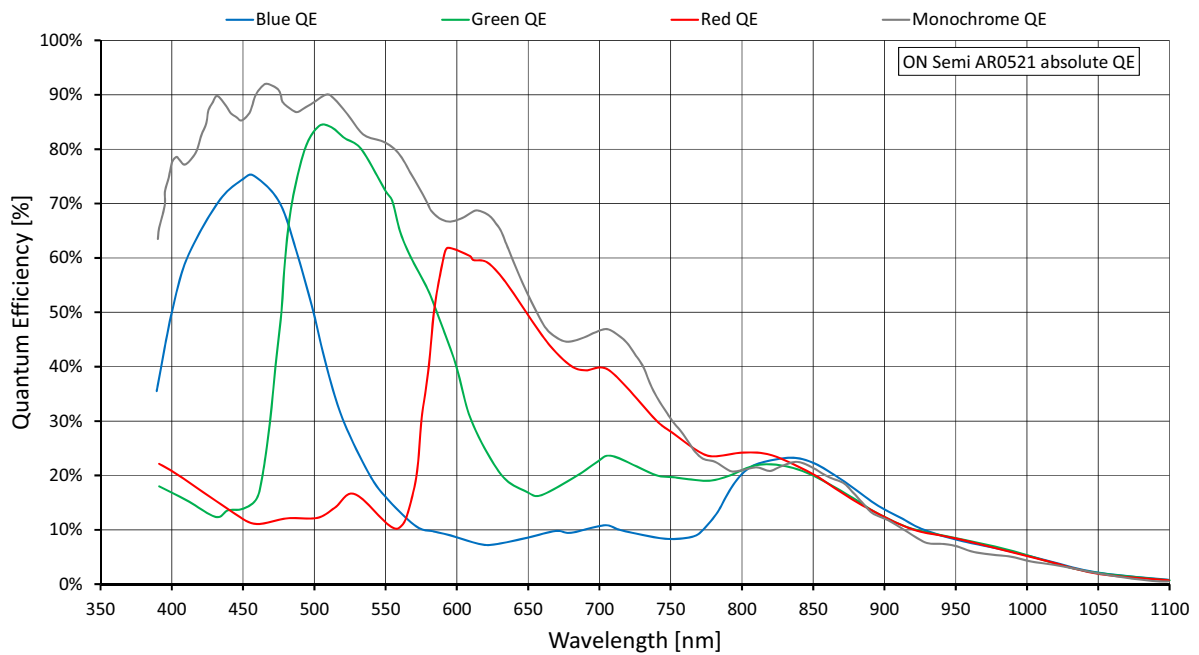

Figure 15: Alvium G1-500m/c (ON Semi AR0521) absolute QE

### Spectral response

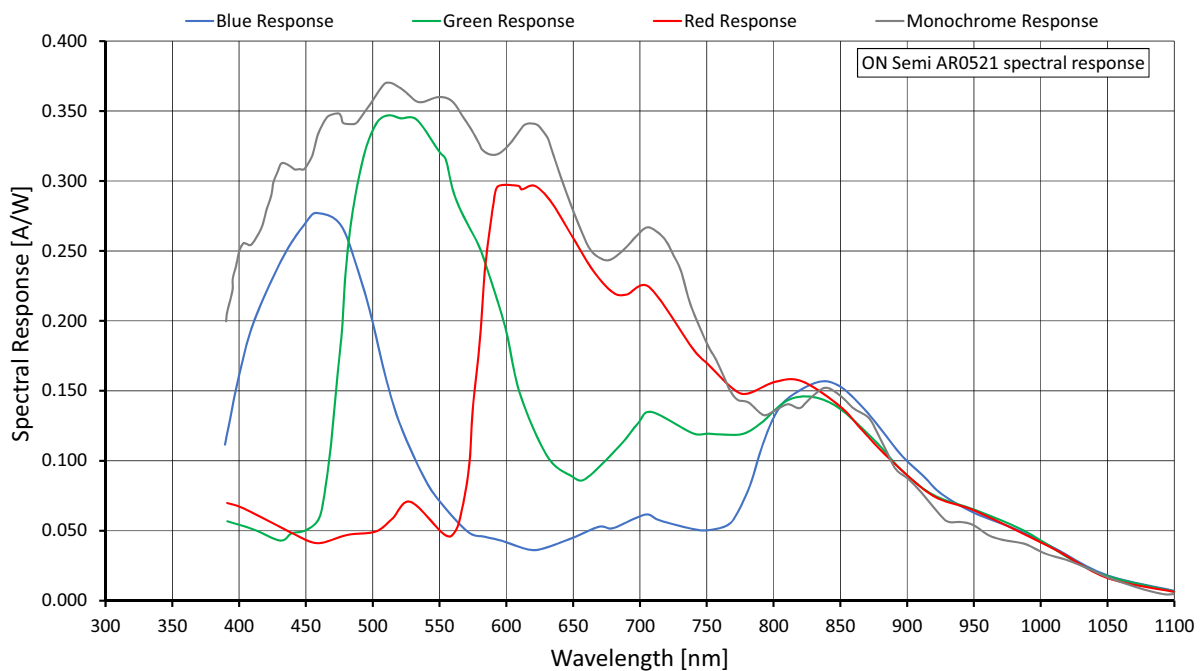

Figure 16: Alvium G1-500m/c (ON Semi AR0521) spectral response

## ROI frame rates

Values are based on the conditions defined in [Specified values](#) on page 46.

Shutter mode	User mode	Available frame rates
RS	Freerun	Values in <a href="#">Table 30</a> below
RS	Triggered	Values for <b>full resolution</b> in <a href="#">Table 30</a> below are approximately <b>divided by 2</b> and apply to all resolutions.

*Table 29: Frame rate behavior for different configurations*

Currently, Alvium G1-500 models can be operated only at 122 MByte/s.

Image format	Width [pixels]	Height [pixels]	ROI area [MP]	Frame rate [fps] <sup>1</sup>
				122 MByte/s
Full resolution	2592	1944	5.039	23.6/11.8
WQHD	2560	1440	3.686	32.1/16.1
QXGA	2048	1536	3.146	37.7/18.9
Full HD	1920	1080	2.074	56.5/28.3
UXGA	1600	1200	1.920	61.4/30.7
WXGA+	1440	900	1.296	89.7/45.0
SXGA	1280	1024	1.311	89.3/44.8
HD 720	1280	720	0.922	125.0/62.7
XGA	1024	768	0.786	147.0/73.8
SVGA	800	600	0.480	211.7/119.1
VGA	640	480	0.307	260.8/183.2
HVGA	480	320	0.154	377.1/352.5
QVGA	320	240	0.077	486.2/487.9
HQVGA	240	160	0.038	684.0/684.0
QQVGA	160	120	0.019	856.0/856.0
Max. × half	2592	972	2.519	46.3/23.2
Max. × min.	2592	8	0.021	905.4/480.8
Min. × max.	8	1944	0.016	68.6/68.6
Min. × min.	8	8	64 P	2892.5/2892.5

<sup>1</sup> Mono8 or Bayer...8<sup>(2)</sup> at `SensorBitDepth = 10-Bit` /  
 Mono10 or Bayer...10 at `SensorBitDepth = 10-Bit`

<sup>2</sup> The three dots... represent the colors of a Bayer pixel format, such as in Bayer**RG8**.

*Table 30: Alvium G1-500m/c ROI frame rates*

## Alvium G1-507m/c

Feature	Specification	
	G1-507m (monochrome)	G1-507c (color)
Sensor model	Sony IMX264	
Resolution	2464 (H) × 2056 (V); 5.1 MP	
Sensor type	CMOS	
Shutter type	Global shutter (GS)	
Sensor size	Type 2/3; 8.5 mm × 7.1 mm; 11.1 mm diagonal	
Pixel size	3.45 μm × 3.45 μm	
CRA	0 deg	
Sensor bit depth (ADC)	12-bit	
Monochrome pixel formats	Mono8 (default), Mono10, Mono10p, Mono12, Mono12p	Mono8, Mono10, Mono10p, Mono12, Mono12p
YUV color pixel formats	Not applicable	YCbCr411_8_CbYYCrYY, YCbCr422_8_CbYCrY, YCbCr8_CbYCr
RGB color pixel formats	Not applicable	BayerRG8, BayerRG10, BayerRG10p, BayerRG12, BayerRG12p, BGR8, RGB8 (default)
Maximum frame rate	23 fps (at 122 MByte/s)	
Exposure time	55 μs to 10 s (at 122 MByte/s)	
Exposure modes	Timed, TriggerControlled, TriggerWidth	
Gain	0 dB to 48 dB; 0.1 dB increments	
Digital binning	Horizontal: 1 to 8 columns; Vertical: 1 to 8 rows	
Multiple ROI (H × V)	<b>Free</b>	
Image buffer (RAM)	32 MByte	
Non-volatile memory (Flash)	1024 KByte	
Inputs and outputs	1 opto-isolated input, 1 opto-isolated output, 2 non-isolated GPIOs <sup>1</sup>	
Power requirements	12 to 24 VDC	
Power requirements (PoE)	IEEE 802.3af	
Power consumption (typical)	External power: 3.1 W at 12 VDC Power over Ethernet: 3.4 W	
Storage temperature	-20 °C to +85 °C ambient temperature	
Operating temperature	-20 °C to +55 °C (Housing, typical), -20 °C to +85 °C (Mainboard <sup>2</sup> )	
Humidity	0% to 80% humidity (non-condensing)	
Digital interface	1000BASE-T	
Camera controls	GenICam (GenICam Access)	

<sup>1</sup> Use with external power only, not with PoE. See [I/Os and power supply by PoE](#) on page 38.

<sup>2</sup> Output by DeviceTemperature

Table 31: Alvium G1-507m/c specifications

### Absolute QE

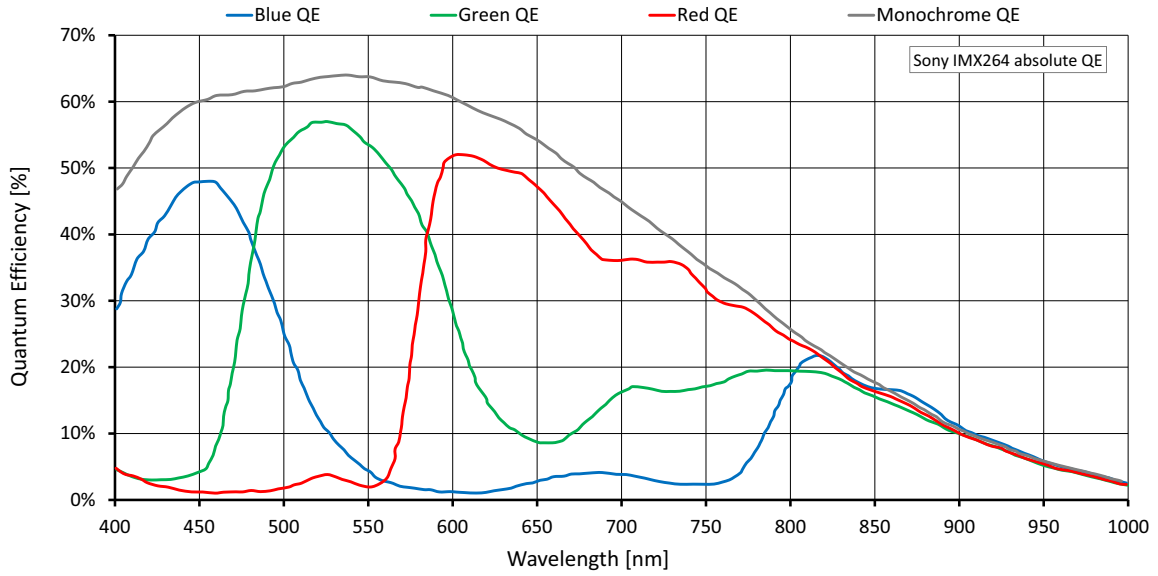

Figure 17: Alvium G1-507m/c (Sony IMX264) absolute QE

### Spectral response

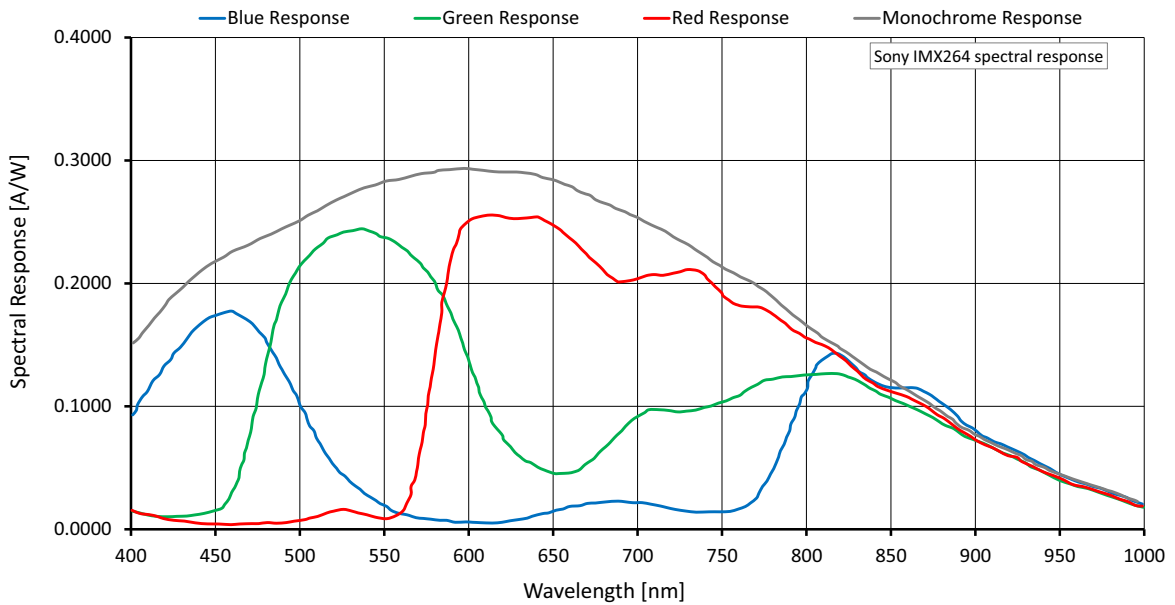

Figure 18: Alvium G1-507m/c (Sony IMX264) spectral response

## ROI frame rates

Values are based on the conditions defined in [Specified values](#) on page 46.

Image format	Width [pixels]	Height [pixels]	ROI area [MP]	Frame rate [fps] <sup>1</sup>	
				122 MByte/s	12 MByte/s
Full resolution	2464	2056	5.066	23.4/11.7	2.3/1.1
QXGA	2048	1536	3.146	37.3/18.7	3.7/1.8
Full HD	1920	1080	2.074	55.7/28.0	5.5/2.8
UXGA	1600	1200	1.920	58.8/30.4	6.0/3.0
WXGA+	1440	900	1.296	77.3/44.4	8.8/4.4
SXGA	1280	1024	1.311	68.6/44.1	8.8/4.4
HD 720	1280	720	0.922	95.4/61.5	12.3/6.2
XGA	1024	768	0.786	90.1/72.5	14.4/7.2
SVGA	800	600	0.480	113.6/113.4	23.3/11.7
VGA	640	480	0.307	139.5/139.5	35.7/18.0
HVGA	480	320	0.154	200.2/200.2	68.5/34.6
QVGA	320	240	0.077	256.4/256.4	131.4/66.4
HQVGA	240	160	0.038	356.2/356.2	223.9/113.5
QQVGA	160	120	0.019	441.0/441.0	277.5/140.9
Max. × half	2464	1028	2.533	45.5/22.9	4.5/2.2
Max. × min.	2464	8	0.020	738.7/412.4	89.1/45.7
Min. × max.	8	2056	0.016	35.2/35.2	22.0/11.1
Min. × min.	8	8	64 P	1323.2/1323.2	842.6/433.1

<sup>1</sup> Mono8 or Bayer...8<sup>(2)</sup> at `SensorBitDepth` = 12-Bit/  
 Mono12 or Bayer...12 at `SensorBitDepth` = 12-Bit

<sup>2</sup> The three dots... represent the colors of a Bayer pixel format, such as in BayerRG8.

Table 32: Alvium G1-507m/c ROI frame rates

## Alvium G1-510m/c

Feature	Specification	
	G1-510m (monochrome)	G1-510c (color)
Sensor model	Sony IMX548-AAMJ	Sony IMX548-AAQJ
Resolution	2464 (H) × 2064 (V); 5.1 MP	
Sensor type	CMOS	
Shutter type	Global shutter (GS)	
Sensor size	Type 1/1.8; 6.75 mm × 5.66 mm; 8.8 mm diagonal	
Pixel size	2.74 μm × 2.74 μm	
CRA	0 deg	
Sensor bit depth (ADC)	12-bit	
Monochrome pixel formats	Mono8 (default), Mono10, Mono10p, Mono12, Mono12p	Mono8, Mono10, Mono10p, Mono12, Mono12p
YUV color pixel formats	Not applicable	YCbCr411_8_CbYYCrYY, YCbCr422_8_CbYCrY, YCbCr8_CbYCr
RGB color pixel formats	Not applicable	BayerRG8, BayerRG10, BayerRG10p, BayerRG12, BayerRG12p, BGR8, RGB8 (default)
Maximum frame rate	22 fps (at 122 MByte/s)	
Exposure time	31 μs to 6.6 s (at 122 MByte/s)	
Exposure modes	Timed	
Gain	0 dB to 48 dB; 0.1 dB increments	
Digital binning	Horizontal: 1 to 8 columns; Vertical: 1 to 8 rows	
Sensor binning (H × V)	2 × 2	Not applicable
Multiple ROI (H × V)	<b>Free   Tile   Horizontal:</b> 1 × 1 to 1 × 4   <b>Vertical:</b> 1 × 1 to 4 × 1	
Image buffer (RAM)	32 MByte	
Non-volatile memory (Flash)	1024 KByte	
Inputs and outputs	1 opto-isolated input, 1 opto-isolated output, 2 non-isolated GPIOs <sup>1</sup>	
Power requirements	12 to 24 VDC	
Power requirements (PoE)	IEEE 802.3af	
Power consumption (typical)	External power: 3.2 W at 12 VDC Power over Ethernet: 3.6 W	
Storage temperature	-20 °C to +85 °C ambient temperature	
Operating temperature	+5 °C to +50 °C (Housing, typical), -20 °C to +85 °C (Mainboard <sup>2</sup> )	
Humidity	0% to 80% humidity (non-condensing)	
Digital interface	1000BASE-T	
Camera controls	GenICam (GenICam Access)	

<sup>1</sup> Use with external power only, not with PoE. See [I/Os and power supply by PoE](#) on page 38.

<sup>2</sup> Output by `DeviceTemperature`

Table 33: Alvium G1-510m/c specifications

## Absolute QE

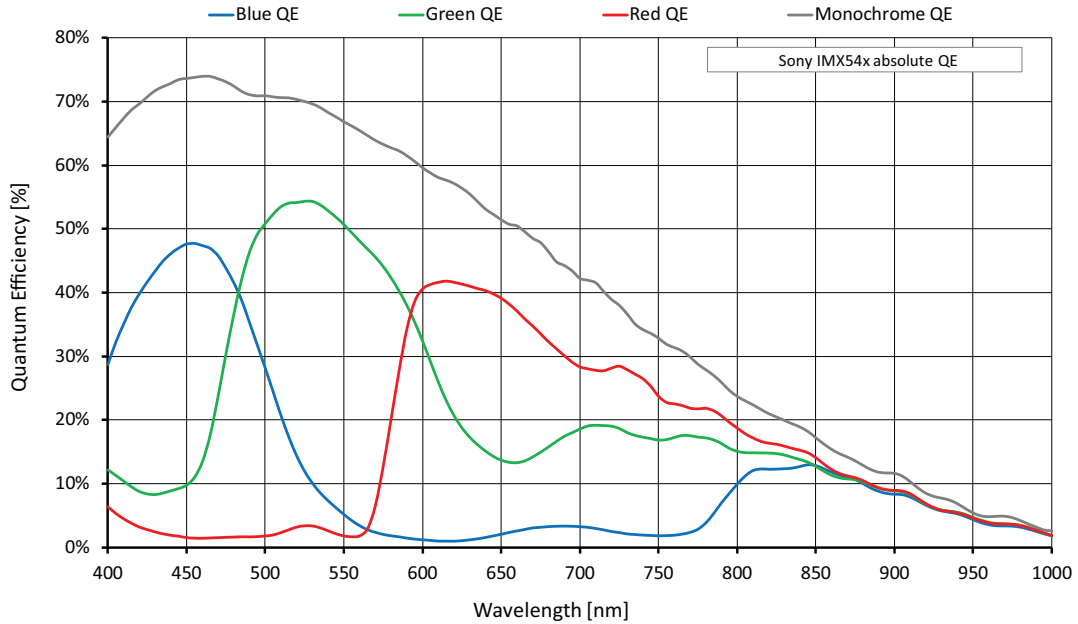

Figure 19: Alvium G1-510m/c (Sony IMX547) absolute QE

## Spectral response

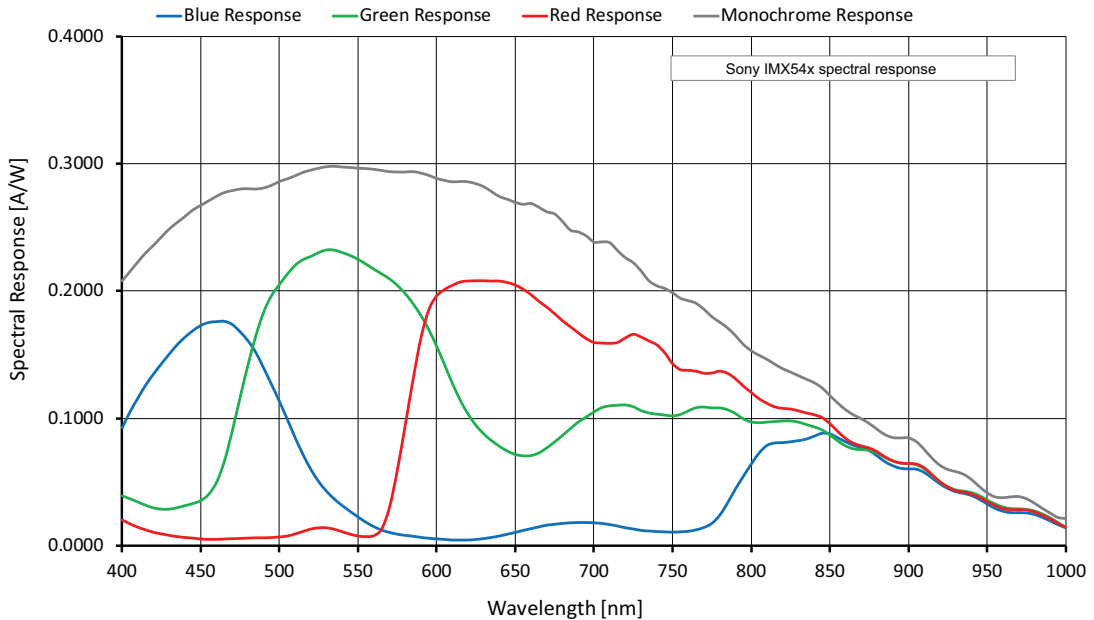

Figure 20: Alvium G1-510m/c (Sony IMX547) spectral response

## ROI frame rates

Values are based on the conditions defined in [Specified values](#) on page 46.

Currently, Alvium G1-510 models can be operated only at 122 MByte/s.

Image format	Width [pixels]	Height [pixels]	ROI area [MP]	Frame rate [fps] <sup>1</sup>
				122 MByte/s
Full resolution	2464	2064	5.086	22.1/11.1
QXGA	2048	1536	3.146	34.8/17.6
Full HD	1920	1080	2.074	51.3/25.8
UXGA	1600	1200	1.920	55.3/28.0
WXGA+	1440	900	1.296	79.4/40.0
SXGA	1280	1024	1.311	79.5/40.4
HD 720	1280	720	0.922	107.1/54.6
XGA	1024	768	0.786	127.6/64.4
SVGA	800	600	0.480	182.3/100.2
VGA	640	480	0.307	217.9/149.2
HVGA	480	320	0.154	291.9/209.8
QVGA	320	240	0.077	351.6/253.7
HQVGA	240	160	0.038	442.1/318.8
QQVGA	160	120	0.019	507.3/366.4
Max. × half	2464	1032	2.543	41.3/20.9
Max. × min.	2464	8	0.020	301.2/159.3
Min. × max.	8	2064	0.017	62.0/44.4
Min. × min.	8	8	64 P	864.7/633.6

<sup>1</sup> Mono8 or Bayer...8<sup>(2)</sup> at SensorBitDepth = 12-Bit / Mono12 or Bayer...12 at SensorBitDepth = 12-Bit

<sup>2</sup> The three dots... represent the colors of a Bayer pixel format, such as in BayerRG8.

Table 34: Alvium G1-510m/c ROI frame rates



## Alvium G1-811m/c

Feature	Specification	
	G1-811m	G1-811c
Sensor model	Sony IMX546-AAMJ	Sony IMX546-AAQJ
Resolution	2848 (H) × 2848 (V); 8.1 MP	
Sensor type	CMOS	
Shutter type	Global shutter (GS)	
Sensor size	Type 2/3; 7.8 mm × 7.8 mm; 11 mm diagonal	
Pixel size	2.74 μm × 2.74 μm	
CRA	0 deg	
Sensor bit depth (ADC)	12-bit	
Monochrome pixel formats	Mono8 (default), Mono10, Mono10p, Mono12, Mono12p	Mono8, Mono10, Mono10p, Mono12, Mono12p
YUV color pixel formats	Not applicable	YCbCr411_8_CbYYCrYY, YCbCr422_8_CbYCrY, YCbCr8_CbYCr
RGB color pixel formats	Not applicable	BayerRG8, BayerRG10, BayerRG10p, BayerRG12, BayerRG12p, BGR8, RGB8 (default)
Maximum frame rate	14 fps (at 122 MByte/s)	
Exposure time	50 μs to 10 s (at 122 MByte/s)	
Exposure modes	Timed	
Gain	0 dB to 48 dB; 0.1 dB increments	
Digital binning	Horizontal: 1 to 8 columns; Vertical: 1 to 8 rows	
Sensor binning (H × V)	2 × 2	Not applicable
Multiple ROI (H × V)	<i>Free</i>   <i>Tile</i>   <i>Horizontal</i> : 1 × 1 to 1 × 4   <i>Vertical</i> : 1 × 1 to 4 × 1	
Non-volatile memory (Flash)	1024 KByte	
Inputs and outputs	1 opto-isolated input, 1 opto-isolated output, 2 non-isolated GPIOs <sup>1</sup>	
Power requirements	12 to 24 VDC	
Power requirements (PoE)	IEEE 802.3af	
Power consumption (typical)	External power: 3.7 W at 12 VDC Power over Ethernet: 4.0 W	
Storage temperature	-20 °C to +85 °C ambient temperature	
Operating temperature	-20 °C to +50 °C (Housing, typical), -20 °C to +85 °C (Mainboard <sup>2</sup> )	
Humidity	0% to 80% humidity (non-condensing)	
Digital interface	1000BASE-T	
Camera controls	GenICam (GenICam Access)	

<sup>1</sup> Use with external power only, not with PoE. See [I/Os and power supply by PoE](#) on page 38.

<sup>2</sup> Output by DeviceTemperature

Table 35: Alvium G1-811m/c specifications

## Absolute QE

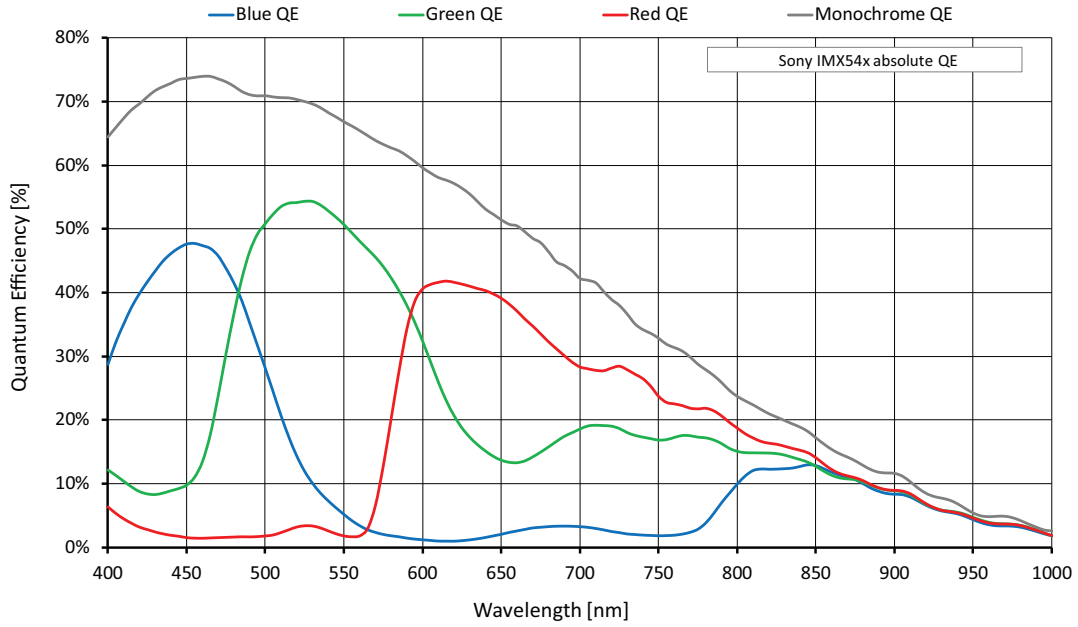

Figure 21: Alvium G1-811m/c (Sony IMX546) absolute QE

## Spectral response

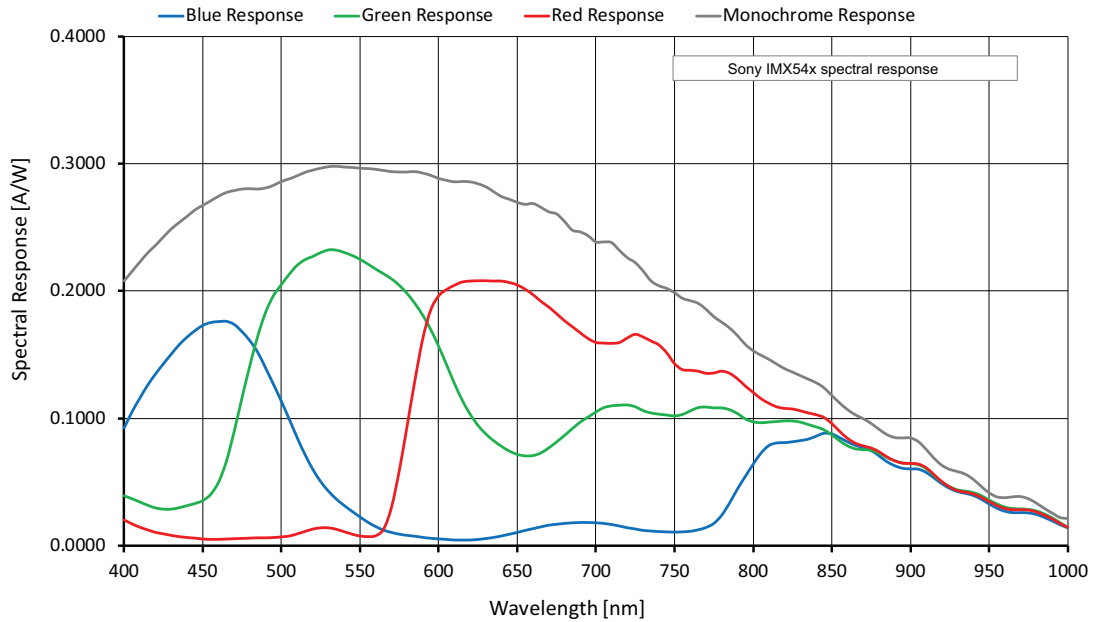

Figure 22: Alvium G1-811m/c (Sony IMX546) spectral response

## ROI frame rates

Values are based on the conditions defined in [Specified values](#) on page 46.

Currently, Alvium G1-811 models can be operated only at 122 MByte/s.

Image format	Width [pixels]	Height [pixels]	ROI area [MP]	Frame rate [fps] <sup>1</sup>
				122 MByte/s
Full resolution	2848	2848	8.111	14.1/7.1
QSXGA	2560	2048	5.243	21.5/10.8
WQHD	2560	1440	3.686	29.8/15.0
QXGA	2048	1536	3.146	34.9/17.6
Full HD	1920	1080	2.074	51.6/25.9
UXGA	1600	1200	1.920	55.5/28.2
WXGA+	1440	900	1.296	79.9/40.2
SXGA	1280	1024	1.311	79.9/40.6
HD 720	1280	720	0.922	107.8/55.0
XGA	1024	768	0.786	128.5/64.8
SVGA	800	600	0.480	162.6/101.0
VGA	640	480	0.307	194.4/150.7
HVGA	480	320	0.154	262.0/212.5
QVGA	320	240	0.077	316.7/257.7
HQVGA	240	160	0.038	400.4/325.2
QQVGA	160	120	0.019	461.3/374.8
Max. × half	2848	1424	4.056	27.0/13.6
Max. × min.	2848	8	0.023	270.8/143.4
Min. × max.	8	2848	0.023	40.5/32.8
Min. × min.	8	8	64 P	803.4/659.1

<sup>1</sup> Mono8 or Bayer...8<sup>(2)</sup> at SensorBitDepth = 12-Bit /  
 Mono12 or Bayer...12 at SensorBitDepth = 12-Bit

<sup>2</sup> The three dots... represent the colors of a Bayer pixel format, such as in BayerRG8.

Table 36: Alvium G1-811m/c ROI frame rates

## Alvium G1-812 UV



### NOTICE

#### Sensor aging by UV radiation

The sensor in this camera model is dedicated for imaging in the UV spectrum. However, UV radiation causes aging, which is permanently increasing the dark current and decreasing the QE (quantum efficiency).

To reduce sensor aging, we recommend you to:

- Minimize the intensity of UV radiation.
- Avoid wavelengths below 250 nm. For example, consider the use of bandpass filters to block shorter wavelengths.

Feature	Specification	
	G1-812 (monochrome)	
Sensor model	Sony IMX487	
Resolution	2848 (H) × 2848 (V); 8.1 MP	
Sensor type	CMOS	
Shutter type	Global shutter (GS)	
Sensor size	Type 2/3; 7.8 mm × 7.8 mm; 11 mm diagonal	
Pixel size	2.74 μm × 2.74 μm	
CRA	0 deg	
Sensor bit depth (ADC)	12-bit	
Monochrome pixel formats	Mono8 (default), Mono10, Mono10p, Mono12, Mono12p	
Maximum frame rate	14 fps (at 122 MByte/s)	
Exposure time	49 μs to 10 s (at 122 MByte/s)	
Exposure modes	Timed, TriggerControlled, TriggerWidth	
Gain	0 dB to 48 dB; 0.1 dB increments	
Digital binning	Horizontal: 1 to 8 columns; Vertical: 1 to 8 rows	
Sensor binning (H × V)	2 × 2	Not applicable
Multiple ROI (H × V)	<i>Free   Tile   Horizontal</i> : 1 × 1 to 1 × 4   <i>Vertical</i> : 1 × 1 to 4 × 1	
Image buffer (RAM)	32 MByte	
Non-volatile memory (Flash)	1024 KByte	
Inputs and outputs	1 opto-isolated input, 1 opto-isolated output, 2 non-isolated GPIOs <sup>1</sup>	
Power requirements	12 to 24 VDC	
Power requirements (PoE)	IEEE 802.3af	
Power consumption (typical)	External power: 4.0 W at 12 VDC Power over Ethernet: 4.6 W	

Table 37: Alvium G1-812 UV specifications (sheet 1 of 2)

Feature	Specification
<sup>1</sup> Use with external power only, not with PoE. See <a href="#">I/Os and power supply by PoE</a> on page 38.	
Storage temperature	-20 °C to +85 °C ambient temperature
Operating temperature	-20 °C to +50 °C (Housing, typical), -20 °C to +85 °C (Mainboard <sup>2</sup> )
Humidity	0% to 80% humidity (non-condensing)
Digital interface	1000BASE-T
Camera controls	GenICam (GenICam Access)
<sup>2</sup> Output by DeviceTemperature	

*Table 37: Alvium G1-812 UV specifications (sheet 2 of 2)*

## Absolute QE

Diagrams will be added in a future version of this document.

## Spectral response

Diagrams will be added in a future version of this document.

## ROI frame rates

Values are based on the conditions defined in [Specified values](#) on page 46.

Currently, Alvium G1-812 UV models can be operated only at 122 MByte/s.

Image format	Width [pixels]	Height [pixels]	ROI area [MP]	Frame rate [fps] <sup>1</sup>
				122 MByte/s
Full resolution	2848	2848	8.111	14.1 / 7.0
QSXGA	2560	2048	5.243	21.3 / 10.6
WQHD	2560	1440	3.686	29.3 / 14.7
QXGA	2048	1536	3.146	34.5 / 17.3
Full HD	1920	1080	2.074	49.8 / 25.0
UXGA	1600	1200	1.920	54.9 / 27.6
WXGA+	1440	900	1.296	76.9 / 38.7
SXGA	1280	1024	1.311	78.8 / 39.5
HD 720	1280	720	0.922	105.3 / 52.9
XGA	1024	768	0.786	124.9 / 62.8
SVGA	800	600	0.480	192.1 / 96.6
VGA	640	480	0.307	271.8 / 144.4
HVGA	480	320	0.154	358.2 / 200.0
QVGA	320	240	0.077	426.0 / 238.1
HQVGA	240	160	0.038	525.4 / 294.3
QQVGA	160	120	0.019	579.4 / 325.0
Max. × half	2848	1424	4.056	26.6 / 13.3
Max. × min.	2848	8	0.023	213.8 / 109.8
Min. × max.	8	2848	0.023	59.4 / 32.9
Min. × min.	8	8	64 P	905.6 / 511.7

<sup>1</sup> Mono8 or Bayer...8<sup>(2)</sup> at **SensorBitDepth** = 12-Bit / Mono12 or Bayer...12 at **SensorBitDepth** = 12-Bit

<sup>2</sup> The three dots... represent the colors of a Bayer pixel format, such as in Bayer**RG8**.

Table 38: Alvium G1-812 UV ROI frame rates

## Alvium G1-1236m/c

Feature	Specification	
	G1-1236m (monochrome)	G1-1236c (color)
Sensor model	Sony IMX304	
Resolution	4112 (H) × 3008 (V); 12.4 MP	
Sensor type	CMOS	
Shutter type	Global shutter (GS)	
Sensor size	Type 1.1; 14.2 mm × 10.4 mm; 17.6 mm diagonal	
Pixel size	3.45 μm × 3.45 μm	
CRA	0 deg	
Sensor bit depth (ADC)	12-bit	
Monochrome pixel formats	Mono8 (default), Mono10, Mono10p, Mono12, Mono12p	Mono8, Mono10, Mono10p, Mono12, Mono12p
YUV color pixel formats	Not applicable	YCbCr411_8_CbYYCrYY, YCbCr422_8_CbYCrY, YCbCr8_CbYCr
RGB color pixel formats	Not applicable	BayerRG8, BayerRG10, BayerRG10p, BayerRG12, BayerRG12p, BGR8, RGB8 (default)
Maximum frame rate	9.6 fps (at 122 MByte/s)	
Exposure time	83 μs to 10 s (at 122 MByte/s)	
Exposure modes	Timed, TriggerControlled, TriggerWidth	
Gain	0 dB to 48 dB; 0.1 dB increments	
Digital binning <sup>1</sup>	Horizontal: 1 to 8 columns; Vertical: 1 to 8 rows	
Multiple ROI (H × V)	<i>Free</i>	
Image buffer (RAM)	32 MByte	
Non-volatile memory (Flash)	1024 KByte	
Inputs and outputs	1 opto-isolated input, 1 opto-isolated output, 2 non-isolated GPIOs <sup>2</sup>	
Power requirements	12 to 24 VDC	
Power requirements (PoE)	IEEE 802.3af	
Power consumption (typical)	External power: 3.8 W at 12 VDC Power over Ethernet: 4.0 W	
Storage temperature	-20 °C to +85 °C ambient temperature	
Operating temperature	-20 °C to +50 °C (Housing, typical), -20 °C to +88 °C (Mainboard <sup>3</sup> )	
Humidity	0% to 80% humidity (non-condensing)	
Digital interface	1000BASE-T	
Camera controls	GenICam (GenICam Access)	
<sup>1</sup> Digital vertical binning can be used only when digital horizontal binning is used as well.		
<sup>2</sup> Use with external power only, not with PoE. See <a href="#">I/Os and power supply by PoE</a> on page 38.		
<sup>3</sup> Output by <code>DeviceTemperature</code>		

Table 39: Alvium G1-1236m/c specifications

### Absolute QE

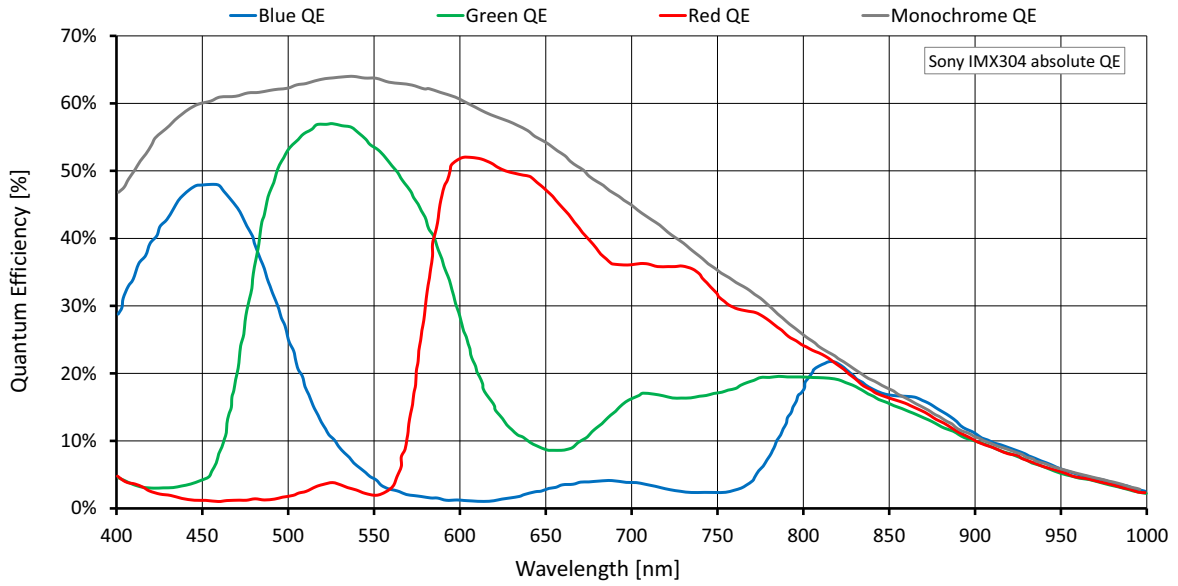

Figure 23: Alvim G1-1236m/c (Sony IMX304) absolute QE

### Spectral response

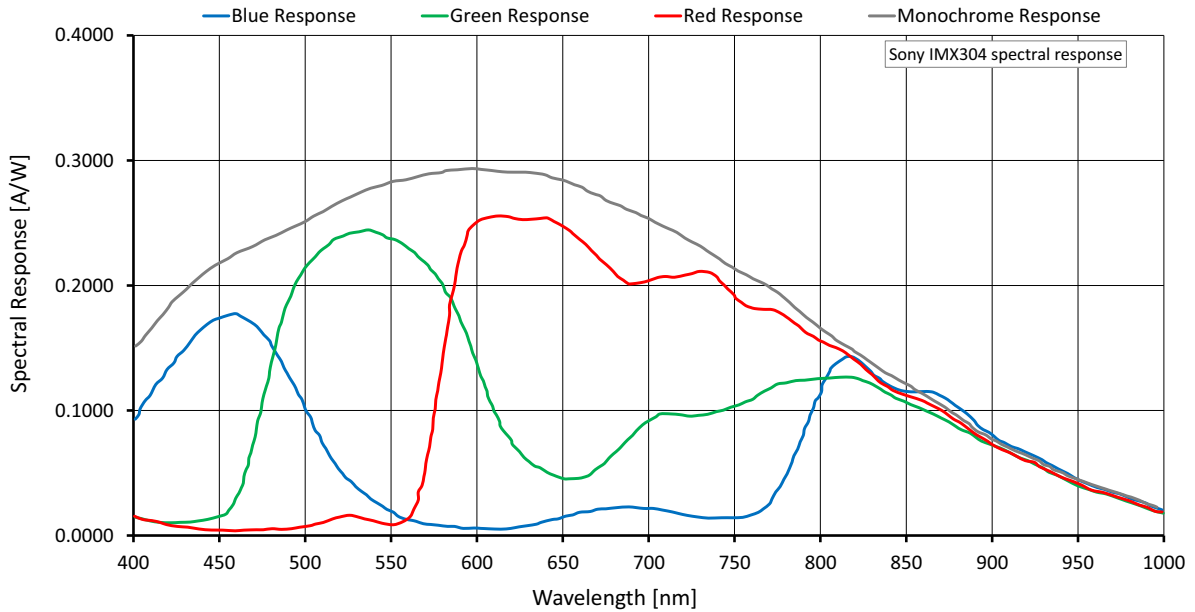

Figure 24: Alvim G1-1236m/c (Sony IMX304) spectral response



## ROI frame rates

Values are based on the conditions defined in [Specified values](#) on page 46.

Currently, Alvium G1-1236 models can be operated only at 122 MByte/s.

Image format	Width [pixels]	Height [pixels]	ROI area [MP]	Frame rate [fps] <sup>1</sup>
				122 MByte/s
Full resolution	4112	3008	12.369	9.6/4.8
UHD 4K	3840	2160	8.294	14.2/7.1
QSXGA	2560	2048	5.243	22.5/11.3
WQHD	2560	1440	3.686	31.6/15.9
QXGA	2048	1536	3.146	37.1/18.7
Full HD	1920	1080	2.074	55.4/27.9
UXGA	1600	1200	1.920	56.2/30.2
WXGA+	1440	900	1.296	73.8/44.2
SXGA	1280	1024	1.311	65.5/43.9
HD 720	1280	720	0.922	91.0/61.1
XGA	1024	768	0.786	85.9/72.1
SVGA	800	600	0.480	108.2/108.2
VGA	640	480	0.307	132.6/132.6
HVGA	480	320	0.154	190.1/190.1
QVGA	320	240	0.077	242.7/242.7
HQVGA	240	160	0.038	335.4/335.4
QQVGA	160	120	0.019	413.4/413.4
Max. × half	4112	1504	6.184	18.9/9.5
Max. × min.	4112	8	0.033	406.5/224.8
Min. × max.	8	3008	0.024	23.2/23.2
Min. × min.	8	8	64 P	1185.3/1185.3

<sup>1</sup> Mono8 or Bayer...8<sup>(2)</sup> at `SensorBitDepth` = 12-Bit / Mono12 or Bayer...12 at `SensorBitDepth` = 12-Bit

<sup>2</sup> The three dots... represent the colors of a Bayer pixel format, such as in BayerRG8.

Table 40: Alvium G1-1236m/c ROI frame rates

## Alvium G1-1240m/c

Feature	Specification	
	G1-1240m (monochrome)	G1-1240c (color)
Sensor model	Sony IMX226	
Resolution	4024 (H) x 3036 (V); 12.2 MP	
Sensor type	CMOS	
Shutter type	Rolling shutter (RS) or Global reset shutter (GRS)	
Sensor size	Type 1/1.7; 7.4 mm x 5.6 mm; 9.33 mm diagonal	
Pixel size	1.85 $\mu\text{m}$ x 1.85 $\mu\text{m}$	
CRA	0 deg	
Sensor bit depth (ADC)	10-bit	
Monochrome pixel formats	Mono8 (default), Mono10, Mono10p	Mono8, Mono10, Mono10p
YUV color pixel formats	Not applicable	YCbCr411_8_CbYYCrYY, YCbCr422_8_CbYCrY, YCbCr8_CbYCr
RGB color pixel formats	Not applicable	BayerRG8, BayerRG10, BayerRG10p, BGR8, RGB8 (default)
Maximum frame rate	9.7 fps <sup>1</sup> (at 122 MByte/s)	
Exposure time	36 $\mu\text{s}$ to 10 s (at 122 MByte/s)	
Exposure modes	Timed	
Gain	0 dB to 27 dB; 0.1 dB increments	
Digital binning <sup>2</sup>	Horizontal: 1 to 8 columns; Vertical: 1 to 8 rows	
Image buffer (RAM)	32 MByte	
Non-volatile memory (Flash)	1024 KByte	
Inputs and outputs	1 opto-isolated input, 1 opto-isolated output, 2 non-isolated GPIOs <sup>3</sup>	
Power requirements	12 to 24 VDC	
Power requirements (PoE)	IEEE 802.3af	
Power consumption (typical)	External power: 3.6 W at 12 VDC Power over Ethernet: 4.0 W	
Storage temperature	-20 °C to +85 °C ambient temperature	
Operating temperature	-20 °C to +50 °C (Housing, typical), -20 °C to +88 °C (Mainboard <sup>4</sup> )	
Humidity	0% to 80% humidity (non-condensing)	
Digital interface	1000BASE-T	
Camera controls	GenICam (GenICam Access)	
<sup>1</sup> In triggered mode: 4.8 fps		
<sup>2</sup> Digital vertical binning can be used only when digital horizontal binning is used as well.		
<sup>3</sup> Use with external power only, not with PoE. See <a href="#">I/Os and power supply by PoE</a> on page 38.		
<sup>4</sup> Output by DeviceTemperature		

Table 41: Alvium G1-1240m/c specifications

### Absolute QE

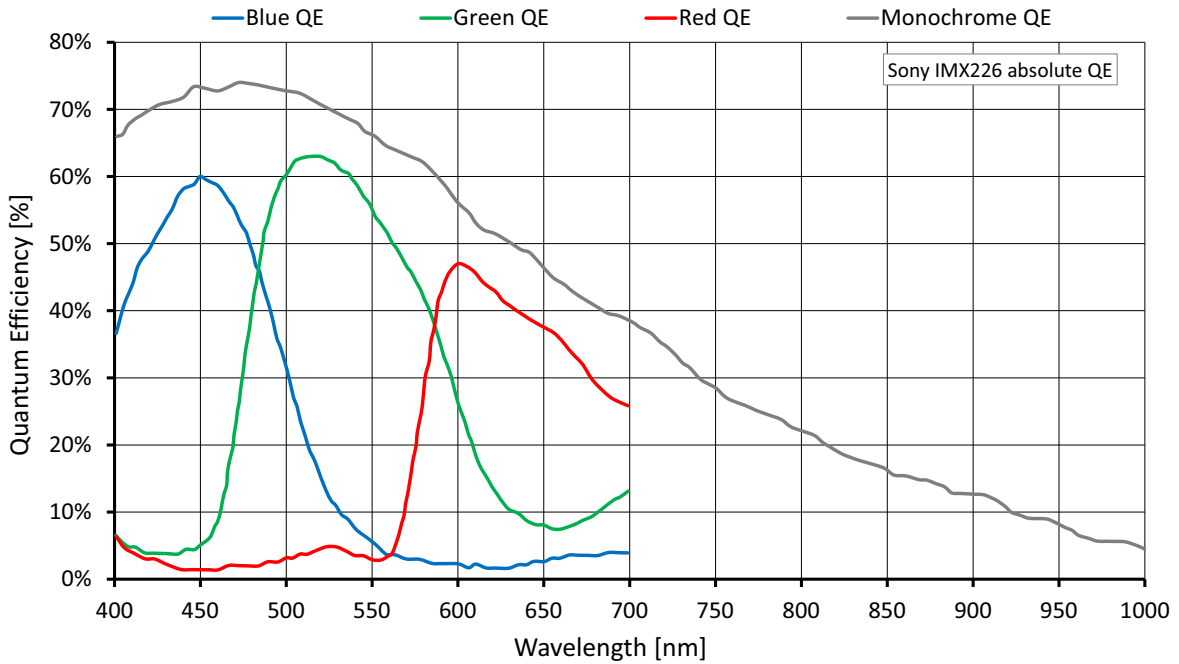

Figure 25: Alvium G1-1240m/c (Sony IMX116) absolute QE

### Spectral response

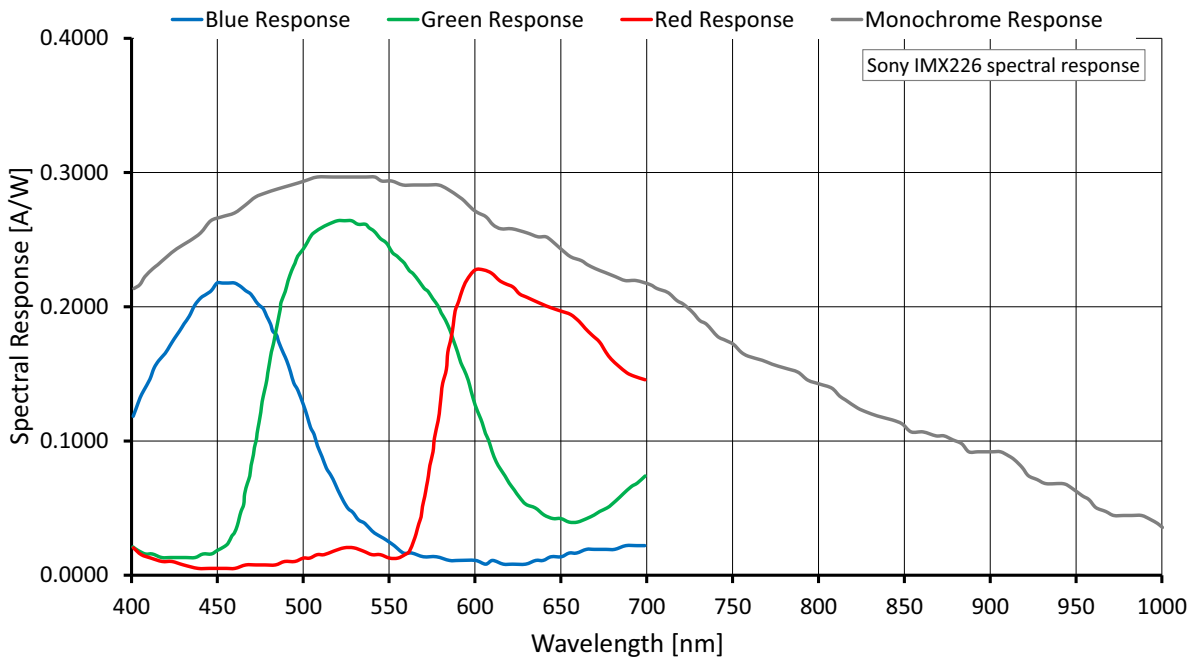

Figure 26: Alvium G1-1240m/c (Sony IMX226) spectral response

## ROI frame rates

Values are based on the conditions defined in [Specified values](#) on page 46.

Shutter mode	User mode	Available frame rates
RS	Freerun	Values in <a href="#">Table 43</a> below
RS	Triggered	Values for <b>full resolution</b> in <a href="#">Table 43</a> below are approximately <b>divided by 2</b> . These full resolution values apply to all resolutions.
GRS	Freerun	Values for <b>full resolution</b> in <a href="#">Table 43</a> below approximately apply to all resolutions.
GRS	Triggered	

*Table 42: Frame rate behavior for different configurations*

Currently, Alvium G1-1240 models can be operated only at 122 MByte/s.

Image format	Width [pixels]	Height [pixels]	ROI area [MP]	Frame rate [fps] <sup>1</sup>
				122 MByte/s
Full resolution	4024	3036	12.217	9.7 / 4.8
UHD 4K	3840	2160	8.294	
QSXGA	2560	2048	5.243	
WQHD	2560	1440	3.686	
QXGA	2048	1536	3.146	
Full HD	1920	1080	2.074	
UXGA	1600	1200	1.920	
WXGA+	1440	900	1.296	
SXGA	1280	1024	1.311	
HD 720	1280	720	0.922	
XGA	1024	768	0.786	
SVGA	800	600	0.480	
VGA	640	480	0.307	
HVGA	480	320	0.154	
QVGA	320	240	0.077	
HQVGA	240	160	0.038	
QQVGA	160	120	0.019	
Max. × half	4024	1518	6.108	
Max. × min.	4024	8	0.032	
Min. × max.	8	3036	0.024	
Min. × min.	8	8	64 P	

<sup>1</sup> Mono8 or Bayer...8<sup>(2)</sup> at **SensorBitDepth** = 10-Bit /  
 Mono12 or Bayer...12 at **SensorBitDepth** = 10-Bit

<sup>2</sup> The three dots... represent the colors of a Bayer pixel format, such as in Bayer**RG8**.

*Table 43: Alvium G1-1240m/c ROI frame rates*

## Alvium G1-1242m/c

Feature	Specification	
	G1-1242m (monochrome)	G1-1242c (color)
Sensor model	Sony IMX545-AAMJ	Sony IMX545-AAQJ
Resolution	4128 (H) × 3008 (V); 12.4 MP	
Sensor type	CMOS	
Shutter type	Global shutter (GS)	
Sensor size	Type 1/1.1; 11.31 mm × 8.24 mm; 14 mm diagonal	
Pixel size	2.74 μm × 2.74 μm	
CRA	0 deg	
Sensor bit depth (ADC)	12-bit	
Monochrome pixel formats	Mono8 (default), Mono10, Mono10p, Mono12, Mono12p	Mono8, Mono10, Mono10p, Mono12, Mono12p
YUV color pixel formats	Not applicable	YCbCr411_8_CbYYCrYY, YCbCr422_8_CbYCrY, YCbCr8_CbYCr
RGB color pixel formats	Not applicable	BayerRG8, BayerRG10, BayerRG10p, BayerRG12, BayerRG12p, BGR8, RGB8 (default)
Maximum frame rate	9.3 fps (at 122 MByte/s)	
Exposure time	72 μs to 10 s (at 122 MByte/s)	
Exposure modes	Timed	
Gain	0 dB to 48 dB; 0.1 dB increments	
Digital binning <sup>1</sup>	Horizontal: 1 to 8 columns; Vertical: 1 to 8 rows	
Sensor binning (H × V)	2 × 2	Not applicable
Multiple ROI (H × V)	<i>Free   Tile   Horizontal</i> : 1 × 1 to 1 × 4   <i>Vertical</i> : 1 × 1 to 4 × 1	
Image buffer (RAM)	32 MByte	
Non-volatile memory (Flash)	1024 KByte	
Inputs and outputs	1 opto-isolated input, 1 opto-isolated output, 2 non-isolated GPIOs <sup>2</sup>	
Power requirements	12 to 24 VDC	
Power requirements (PoE)	IEEE 802.3af	
Power consumption (typical)	External power: 3.8 W at 12 VDC Power over Ethernet: 4.0 W	

Table 44: Alvium G1-1242m/c specifications (sheet 1 of 2)

<b>Feature</b>	<b>Specification</b>
Storage temperature	-20 °C to +85 °C ambient temperature
Operating temperature	-20 °C to +50 °C (Housing, typical), -20 °C to +85 °C (Mainboard <sup>3</sup> )
Humidity	0% to 80% humidity (non-condensing)
Digital interface	1000BASE-T
Camera controls	GenICam (GenICam Access)
<sup>1</sup> Digital vertical binning can be used only when digital horizontal binning is used as well. <sup>2</sup> Use with external power only, not with PoE. See <a href="#">I/Os and power supply by PoE</a> on page 38. <sup>3</sup> Output by DeviceTemperature	

*Table 44: Alvium G1-1242m/c specifications (sheet 2 of 2)*

## Absolute QE

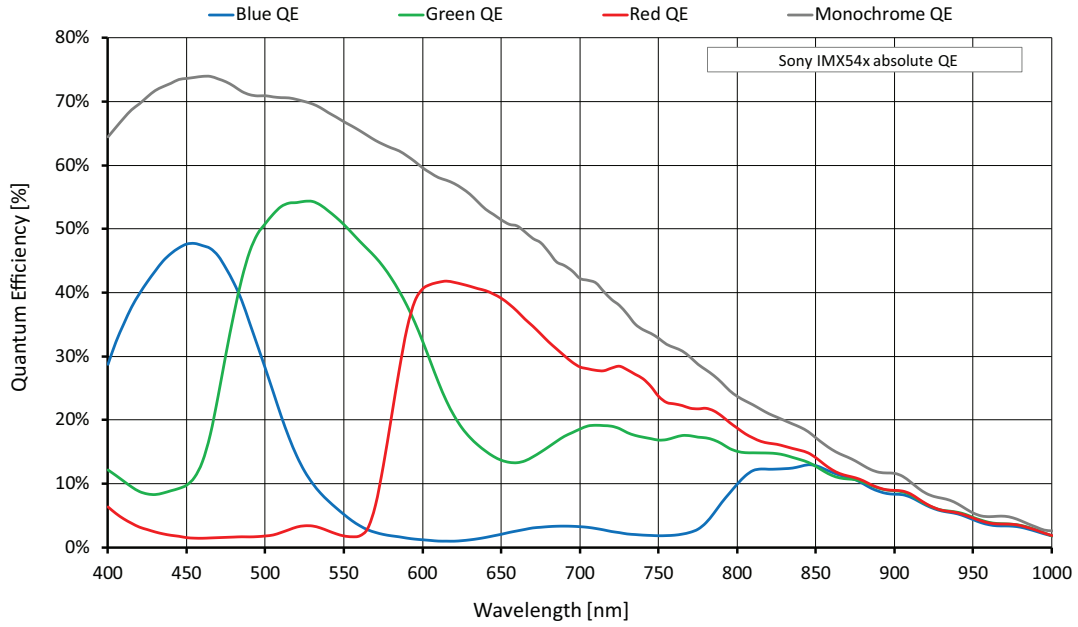

Figure 27: Alvium G1-1242m/c (Sony IMX545) absolute QE

## Spectral response

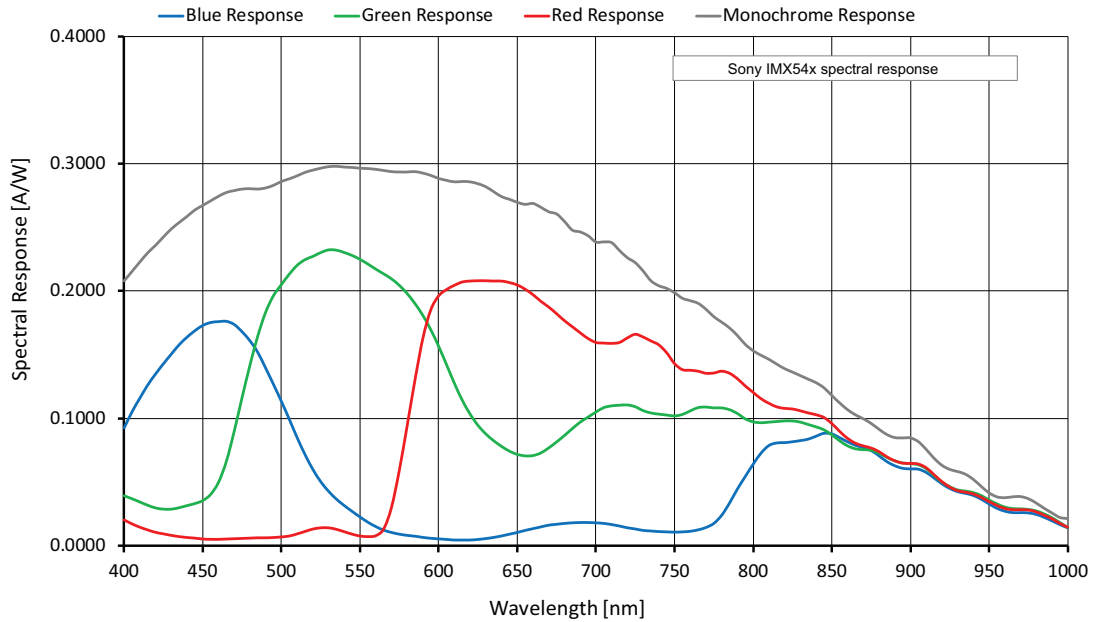

Figure 28: Alvium G1-1242m/c (Sony IMX545) spectral response

## ROI frame rates

Values are based on the conditions defined in [Specified values](#) on page 46.

Currently, Alvium G1-1242 models can be operated only at 122 MByte/s.

Image format	Width [pixels]	Height [pixels]	ROI area [MP]	Frame rate [fps] <sup>1</sup>
				122 MByte/s
Full resolution	4128	3008	12.417	9.3/4.7
UHD 4K	3840	2160	8.294	13.7/6.9
QSXGA	2560	2048	5.243	21.7/10.9
WQHD	2560	1440	3.686	30.1/15.1
QXGA	2048	1536	3.146	35.4/17.8
Full HD	1920	1080	2.074	51.9/26.2
UXGA	1600	1200	1.920	56.6/28.5
WXGA+	1440	900	1.296	81.0/40.8
SXGA	1280	1024	1.311	75.3/41.1
HD 720	1280	720	0.922	102.0/55.7
XGA	1024	768	0.786	96.9/65.9
SVGA	800	600	0.480	119.4/103.4
VGA	640	480	0.307	143.1/142.9
HVGA	480	320	0.154	193.7/193.7
QVGA	320	240	0.077	235.2/235.2
HQVGA	240	160	0.038	299.5/299.5
QQVGA	160	120	0.019	346.8/346.8
Max. × half	4128	1504	6.209	17.9/9.0
Max. × min.	4128	8	0.033	196.8/104.1
Min. × max.	8	3008	0.024	27.9/27.9
Min. × min.	8	8	64 P	622.4/622.4

<sup>1</sup> Mono8 or Bayer...8<sup>(2)</sup> at `SensorBitDepth` = 12-Bit /  
Mono12 or Bayer...12 at `SensorBitDepth` = 12-Bit

<sup>2</sup> The three dots... represent the colors of a Bayer pixel format, such as in BayerRG8.

Table 45: Alvium G1-1242m/c ROI frame rates



## Alvium G1-1620m/c

Feature	Specification	
	G1-1620m	G1-1620c
Sensor model	Sony IMX542-AAMJ	
Resolution	5328 (H) × 3040 (V); 16.2 MP	
Sensor type	CMOS	
Shutter type	Global shutter (GS)	
Sensor size	Type 1.1; 14.6 mm × 8.33 mm; 16.8 mm diagonal	
Pixel size	2.74 μm × 2.74 μm	
CRA	0 deg	
Sensor bit depth (ADC)	12-bit	
Monochrome pixel formats	Mono8 (default), Mono10, Mono10p, Mono12, Mono12p	Mono8, Mono10, Mono10p, Mono12, Mono12p
YUV color pixel formats	Not applicable	YCbCr411_8_CbYYCrYY, YCbCr422_8_CbYCrY, YCbCr8_CbYCr
RGB color pixel formats	Not applicable	BayerRG8, BayerRG10, BayerRG10p, BayerRG12, BayerRG12p, BGR8, RGB8 (default)
Maximum frame rate	7.2 fps (at 122 MByte/s)	
Exposure time	91 μs to 10 s (at 122 MByte/s)	
Exposure modes	Timed, TriggerControlled, TriggerWidth	
Gain	0 dB to 48 dB; 0.1 dB increments	
Digital binning <sup>1</sup>	Horizontal: 1 to 8 columns; Vertical: 1 to 8 rows	
Sensor binning (H × V)	2 × 2	Not applicable
Multiple ROI (H × V)	<i>Free   Tile   Horizontal</i> : 1 × 1 to 1 × 4   <i>Vertical</i> : 1 × 1 to 4 × 1	
Non-volatile memory (Flash)	1024 KByte	
Inputs and outputs	1 opto-isolated input, 1 opto-isolated output, 2 non-isolated GPIOs <sup>2</sup>	
Power requirements	12 to 24 VDC	
Power requirements (PoE)	IEEE 802.3af	
Power consumption (typical)	External power: 3.7 W at 12 VDC Power over Ethernet: 4.1 W	
Storage temperature	-20 °C to +85 °C ambient temperature	
Operating temperature	-20 °C to +50 °C (Housing, typical), -20 °C to +85 °C (Mainboard <sup>3</sup> )	
Humidity	0% to 80% humidity (non-condensing)	
Digital interface	1000BASE-T	
Camera controls	GenICam (GenICam Access)	

<sup>1</sup> Digital vertical binning can be used only when digital horizontal binning is used as well.

<sup>2</sup> Use with external power only, not with PoE. See [I/Os and power supply by PoE](#) on page 38.

<sup>3</sup> Output by `DeviceTemperature`

Table 46: Alvium G1-1620m/c specifications

### Absolute QE

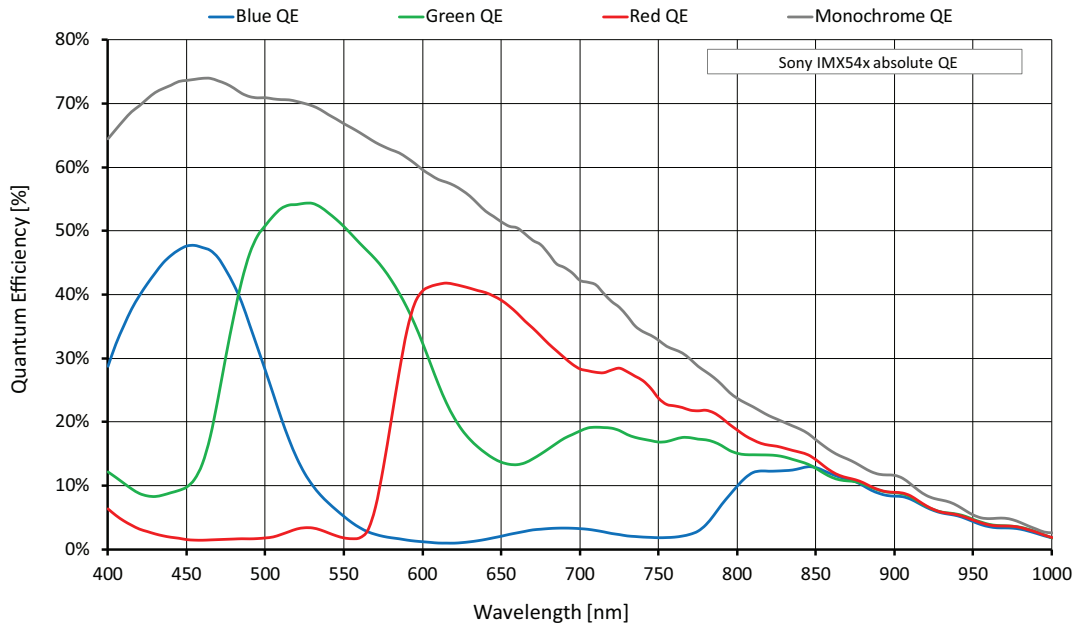

Figure 29: Alvium G1-1620m/c (Sony IMX542) absolute QE

### Spectral response

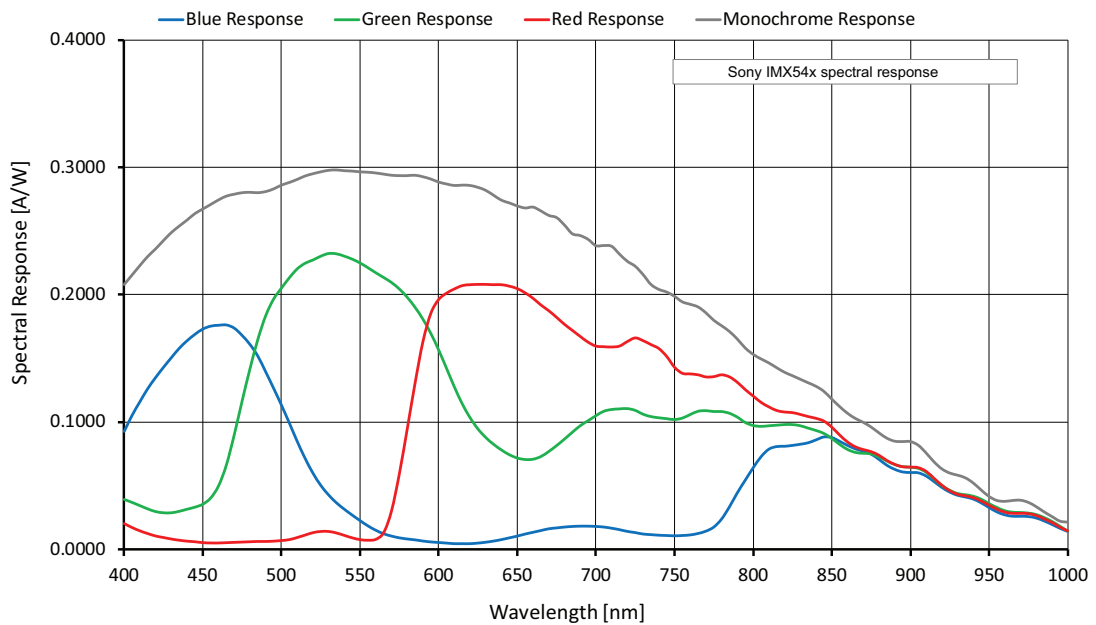

Figure 30: Alvium G1-1620m/c (Sony IMX542) spectral response

## ROI frame rates

Values are based on the conditions defined in [Specified values](#) on page 46.

Currently, Alvium G1-1620 models can be operated only at 122 MByte/s.

Image format	Width [pixels]	Height [pixels]	ROI area [MP]	Frame rate [fps] <sup>1</sup>
				122 MByte/s
Full resolution	5328	3040	16.148	7.4/3.7
UHD 4K	3840	2160	8.294	13.8/6.9
QSXGA	2560	2048	5.243	21.8/11.0
WQHD	2560	1440	3.686	30.2/15.3
QXGA	2048	1536	3.146	35.4/17.9
Full HD	1920	1080	2.074	52.6/26.4
UXGA	1600	1200	1.920	51.9/28.7
WXGA+	1440	900	1.296	66.9/41.1
SXGA	1280	1024	1.311	60.0/41.5
HD 720	1280	720	0.922	81.7/56.5
XGA	1024	768	0.786	77.5/66.5
SVGA	800	600	0.480	95.8/95.8
VGA	640	480	0.307	115.5/115.3
HVGA	480	320	0.154	158.0/158.0
QVGA	320	240	0.077	193.6/193.6
HQVGA	240	160	0.038	249.9/249.9
QQVGA	160	120	0.019	292.5/292.5
Max. × half	5312	1520	8.074	13.9/7.0
Max. × min.	5312	8	0.042	172.3/91.9
Min. × max.	8	3040	0.024	21.7/21.7
Min. × min.	8	8	64 P	558.9/558.9

<sup>1</sup> Mono8 or Bayer...8<sup>(2)</sup> at **SensorBitDepth** = 12-Bit /  
Mono12 or Bayer...12 at **SensorBitDepth** = 12-Bit

<sup>2</sup> The three dots... represent the colors of a Bayer pixel format, such as in Bayer**RG8**.

Table 47: Alvium G1-1620m/c ROI frame rates

## Alvium G1-2040m/c

Feature	Specification	
	G1-2040m (monochrome)	G1-2040c (color)
Sensor model	Sony IMX541-AAMJ	Sony IMX541-AAQJ
Resolution	4512 (H) × 4512 (V); 20.4 MP	
Sensor type	CMOS	
Shutter type	Global shutter (GS)	
Sensor size	Type 1.1; 12.36 mm × 12.36 mm; 17.5 mm diagonal	
Pixel size	2.74 μm × 2.74 μm	
CRA	0 deg	
Sensor bit depth (ADC)	12-bit	
Monochrome pixel formats	Mono8 (default), Mono10, Mono10p, Mono12, Mono12p	Mono8, Mono10, Mono10p, Mono12, Mono12p
YUV color pixel formats	Not applicable	YCbCr411_8_CbYYCrYY, YCbCr422_8_CbYCrY, YCbCr8_CbYCr
RGB color pixel formats	Not applicable	BayerRG8, BayerRG10, BayerRG10p, BayerRG12, BayerRG12p, BGR8, RGB8 (default)
Maximum frame rate	5.8 fps (at 122 MByte/s)	
Exposure time	78 μs to 10 s (at 122 MByte/s)	
Exposure modes	Timed, TriggerControlled, TriggerWidth	
Gain	0 dB to 48 dB; 0.1 dB increments	
Digital binning <sup>1</sup>	Horizontal: 1 to 8 columns; Vertical: 1 to 8 rows	
Sensor binning (H × V)	2 × 2	Not applicable
Multiple ROI (H × V)	<i>Free   Tile   Horizontal:</i> 1 × 1 to 1 × 4   <i>Vertical:</i> 1 × 1 to 4 × 1	
Image buffer (RAM)	32 MByte	
Non-volatile memory (Flash)	1024 KByte	
Inputs and outputs	1 opto-isolated input, 1 opto-isolated output, 2 non-isolated GPIOs <sup>2</sup>	
Power requirements	12 to 24 VDC	
Power requirements (PoE)	IEEE 802.3af	
Power consumption (typical)	External power: 3.8 W at 12 VDC Power over Ethernet: 4.2 W	
Storage temperature	-20 °C to +85 °C ambient temperature	
Operating temperature	-20 °C to +50 °C (Housing, typical), -20 °C to +85 °C (Mainboard <sup>3</sup> )	
Humidity	0% to 80% humidity (non-condensing)	
Digital interface	1000BASE-T	
Camera controls	GenICam (GenICam Access)	

<sup>1</sup> Digital vertical binning can be used only when digital horizontal binning is used as well.

<sup>2</sup> Use with external power only, not with PoE. See [I/Os and power supply by PoE](#) on page 38.

<sup>3</sup> Output by `DeviceTemperature`

Table 48: Alvium G1-2040m/c specifications

## Absolute QE

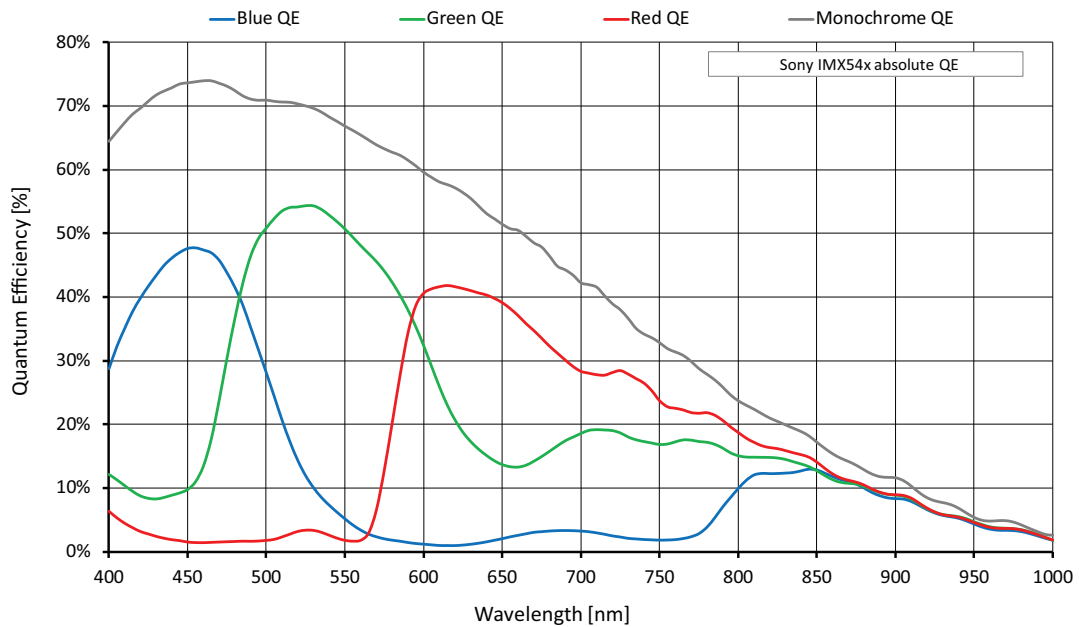

Figure 31: Alvium G1-2040m/c (Sony IMX541) absolute QE

## Spectral response

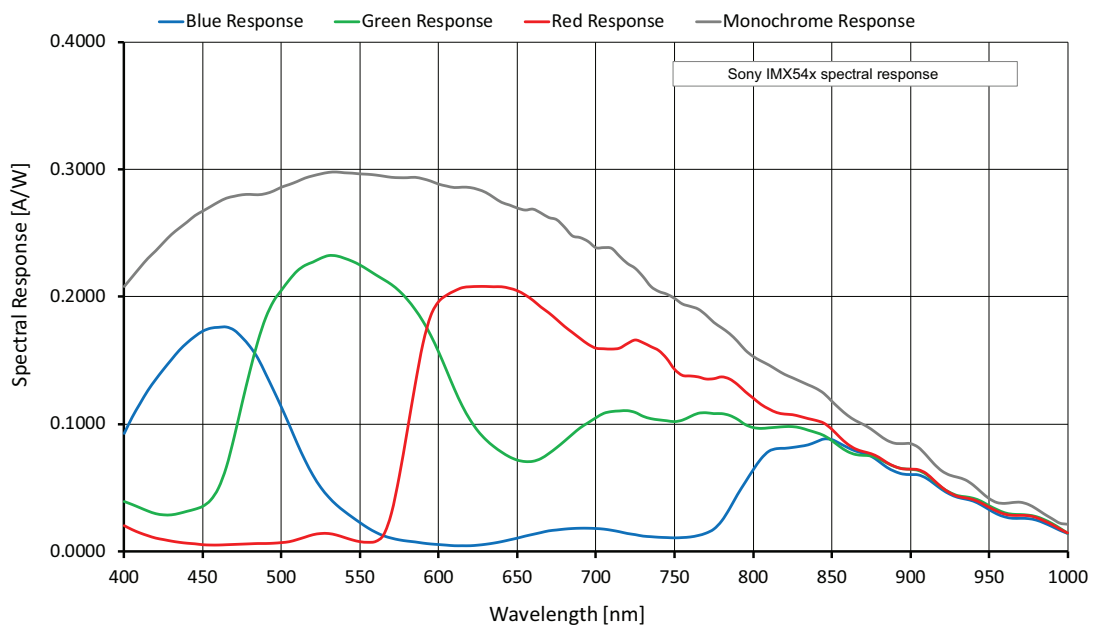

Figure 32: Alvium G1-2040m/c (Sony IMX541) spectral response

## ROI frame rates

Values are based on the conditions defined in [Specified values](#) on page 46.

Currently, Alvium G1-2040 models can be operated only at 122 MByte/s.

Image format	Width [pixels]	Height [pixels]	ROI area [MP]	Frame rate [fps] <sup>1</sup>
				122 MByte/s
Full resolution	4512	4512	20.358	5.8/2.9
HXGA	4096	3072	12.583	9.2/4.6
UHD 4K	3840	2160	8.294	13.8/6.9
QSXGA	2560	2048	5.243	21.7/10.9
WQHD	2560	1440	3.686	30.2/15.2
QXGA	2048	1536	3.146	35.3/17.8
Full HD	1920	1080	2.074	52.4/26.3
UXGA	1600	1200	1.920	56.4/28.6
WXGA+	1440	900	1.296	81.4/41.0
SXGA	1280	1024	1.311	81.3/41.3
HD 720	1280	720	0.922	110.4/56.3
XGA	1024	768	0.786	131.3/66.2
SVGA	800	600	0.480	162.3/103.8
VGA	640	480	0.307	195.1/155.7
HVGA	480	320	0.154	266.0/222.2
QVGA	320	240	0.077	324.6/272.0
HQVGA	240	160	0.038	416.4/348.2
QQVGA	160	120	0.019	485.0/405.8
Max. × half	4512	2256	10.179	11.3/5.6
Max. × min.	4512	8	0.036	196.7/104.8
Min. × max.	8	4512	0.036	25.4/21.1
Min. × min.	8	8	64 P	899.6/761.3

<sup>1</sup> Mono8 or Bayer...8<sup>(2)</sup> at **SensorBitDepth** = 12-Bit /  
 Mono12 or Bayer...12 at **SensorBitDepth** = 12-Bit

<sup>2</sup> The three dots... represent the colors of a Bayer pixel format, such as in Bayer**RG8**.

Table 49: Alvium G1-2040m/c ROI frame rates

## Alvium G1-2050m/c

Feature	Specification	
	G1-2050m (monochrome)	G1-2050c (color)
Sensor model	Sony IMX183	
Resolution	5496 (H) × 3672 (V); 20.2 MP	
Sensor type	CMOS	
Shutter type	Rolling shutter (RS)	
Sensor size	Type 1; 13.1 mm × 8.8 mm; 15.86 mm diagonal	
Pixel size	2.4 μm × 2.4 μm	
CRA	3 deg	
Sensor bit depth (ADC)	10-bit	
Monochrome pixel formats	Mono8 (default), Mono10, Mono10p	Mono8, Mono10, Mono10p
YUV color pixel formats	Not applicable	YCbCr411_8_CbYYCrYY, YCbCr422_8_CbYCrY, YCbCr8_CbYCr
RGB color pixel formats	Not applicable	BayerGR8, BayerGR10, BayerGR10p, BGR8, RGB8 (default)
Maximum frame rate <sup>1</sup>	5.9 fps (at 122 MByte/s)	
Exposure time	48 μs to 10 s (at 122 MByte/s)	
Exposure modes	Timed	
Gain	0 dB to 27 dB; 0.1 dB increments	
Digital binning <sup>2</sup>	Horizontal: 1 to 8 columns; Vertical: 1 to 8 rows	
Image buffer (RAM)	32 MByte	
Non-volatile memory (Flash)	1024 KByte	
Inputs and outputs	1 opto-isolated input, 1 opto-isolated output, 2 non-isolated GPIOs <sup>3</sup>	
Power requirements	12 to 24 VDC	
Power requirements (PoE)	IEEE 802.3af	
Power consumption (typical)	External power: 3.6 W at 12 VDC Power over Ethernet: 3.9 W	
Storage temperature	-20 °C to +85 °C ambient temperature	
Operating temperature	-20 °C to +55 °C (Housing, typical), -20 °C to +88 °C (Mainboard <sup>4</sup> )	
Humidity	0% to 80% humidity (non-condensing)	
Digital interface	1000BASE-T	
Camera controls	GenICam (GenICam Access)	

<sup>1</sup> In triggered mode: 2.5 fps

<sup>2</sup> Digital vertical binning can be used only when digital horizontal binning is used as well.

<sup>3</sup> Use with external power only, not with PoE. See [I/Os and power supply by PoE](#) on page 38.

<sup>4</sup> Output by `DeviceTemperature`

Table 50: Alvium G1-2050m/c specifications

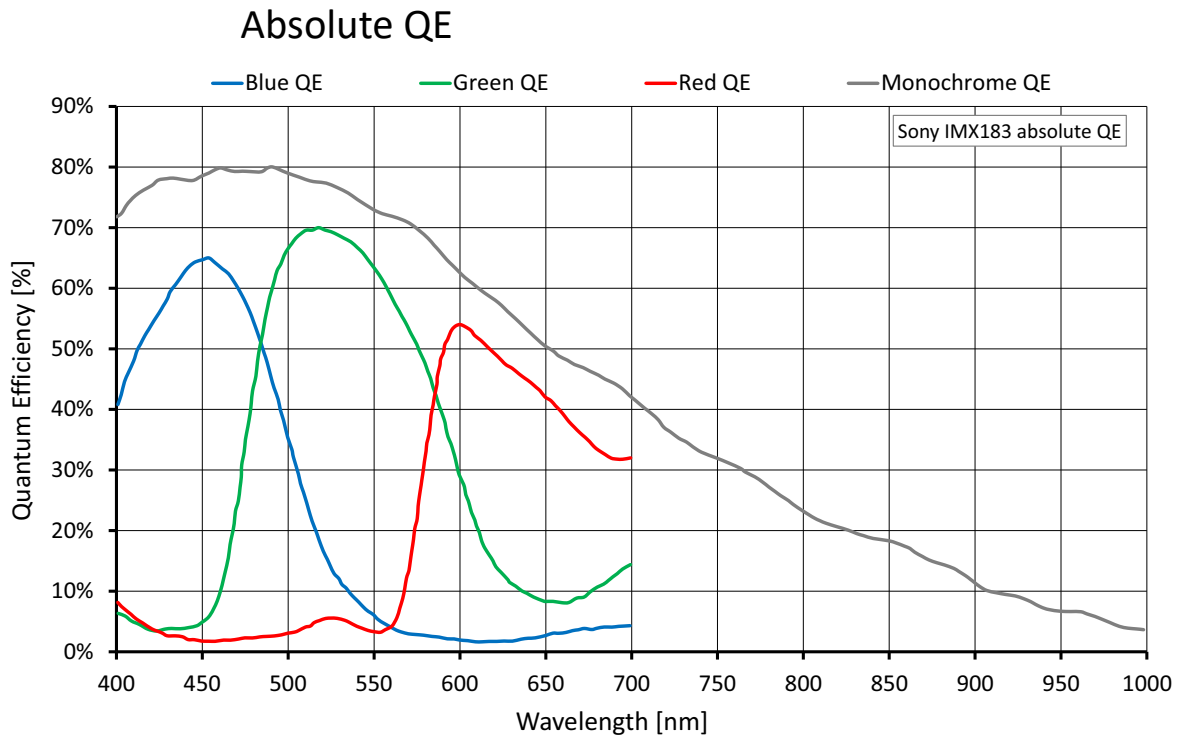

Figure 33: Alvium G1-2050m/c (Sony IMX183) absolute QE

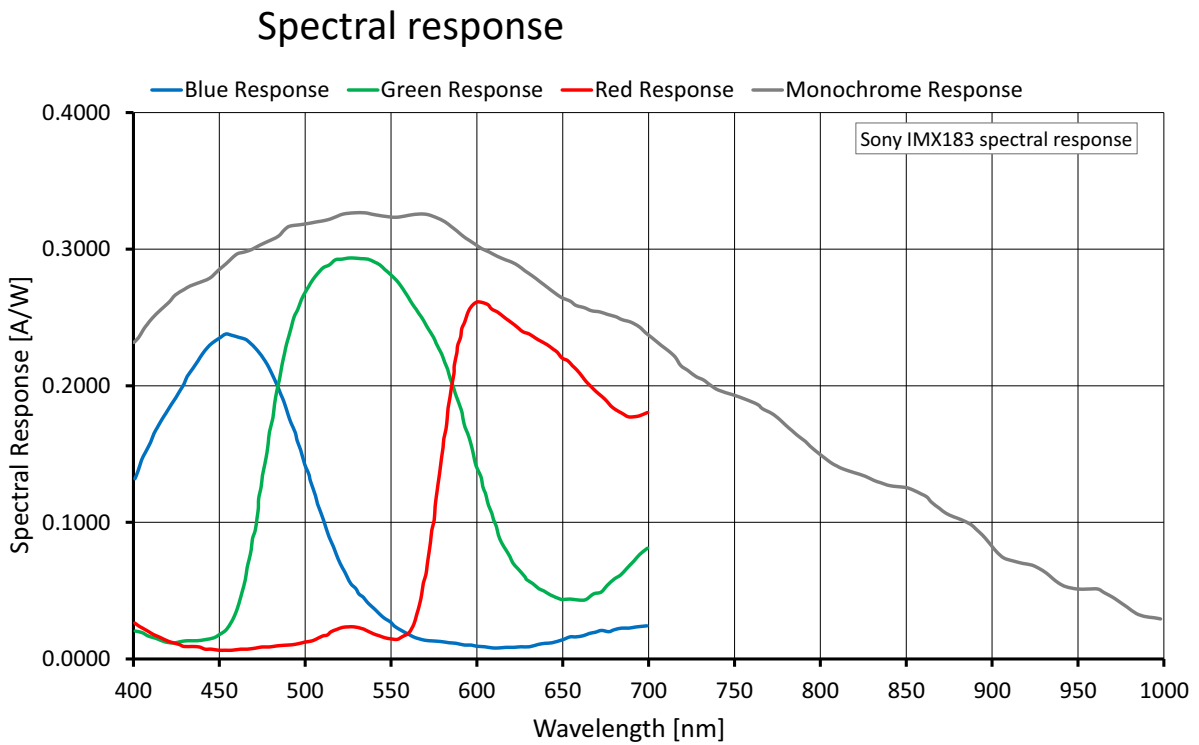

Figure 34: Alvium G1-2050m/c (Sony IMX183) spectral response



## ROI frame rates

Values are based on the conditions defined in [Specified values](#) on page 46.

Shutter mode	User mode	Available frame rates
RS	Freerun	Values in <a href="#">Table 52</a> below
RS	Triggered	Values for <b>full resolution</b> in <a href="#">Table 52</a> below are approximately <b>divided by 2</b> . These full resolution values apply to all resolutions.

*Table 51: Frame rate behavior for different configurations*

Currently, Alvium G1-2050 models can be operated only at 122 MByte/s.

Image format	Width [pixels]	Height [pixels]	ROI area [MP]	Frame rate [fps] <sup>1</sup>
				122 MByte/s
Full resolution	5496	3672	20.181	5.9/2.9
HXGA	4096	3072	12.583	7.0/3.5
UHD 4K	3840	2160	8.294	9.9/4.9
QSXGA	2560	2048	5.243	10.4/5.2
WQHD	2560	1440	3.686	11.5/5.7
QXGA	2048	1536	3.146	11.5/5.7
Full HD	1920	1080	2.074	11.5/5.7
UXGA	1600	1200	1.920	11.5/5.7
WXGA+	1440	900	1.296	11.5/5.7
SXGA	1280	1024	1.311	11.5/5.7
HD 720	1280	720	0.922	11.5/5.7
XGA	1024	768	0.786	11.5/5.7
SVGA	800	600	0.480	11.5/5.7
VGA	640	480	0.307	11.5/5.7
HVGA	480	320	0.154	11.5/5.7
QVGA	320	240	0.077	11.5/5.7
HQVGA	240	160	0.038	11.5/5.7
QQVGA	160	120	0.019	11.5/5.7
Max. × half	5496	1836	10.091	11.5/5.7
Max. × min.	5496	8	0.044	11.5/5.7
Min. × max.	8	3672	0.029	5.9/2.9
Min. × min.	8	8	64 P	11.5/5.7

<sup>1</sup> Mono8 or Bayer...8<sup>(2)</sup> at **SensorBitDepth** = 10-Bit /  
Mono10 or Bayer...10 at **SensorBitDepth** = 10-Bit

<sup>2</sup> The three dots... represent the colors of a Bayer pixel format, such as in Bayer**RG8**.

*Table 52: Alvium G1-2050m/c ROI frame rates*

## Alvium G1-2460m/c

Feature	Specification	
	G1-2460m	G1-2460c
Sensor model	Sony IMX540-AAMJ	Sony IMX540-AAQJ
Resolution	5328 (H) × 4608 (V); 24.6 MP	
Sensor type	CMOS	
Shutter type	Global shutter (GS)	
Sensor size	Type 1.2; 14.60 mm × 12.63 mm; 19.3 mm diagonal	
Pixel size	2.74 μm × 2.74 μm	
CRA	0 deg	
Sensor bit depth (ADC)	12-bit	
Monochrome pixel formats	Mono8 (default), Mono10, Mono10p, Mono12, Mono12p	Mono8, Mono10, Mono10p, Mono12, Mono12p
YUV color pixel formats	Not applicable	YCbCr411_8_CbYYCrYY, YCbCr422_8_CbYCrY, YCbCr8_CbYCr
RGB color pixel formats	Not applicable	BayerRG8, BayerRG10, BayerRG10p, BayerRG12, BayerRG12p, BGR8, RGB8 (default)
Maximum frame rate	4.8 fps (at 122 MByte/s)	
Exposure time	92 μs to 10 s (at 122 MByte/s)	
Exposure modes	Timed, TriggerControlled, TriggerWidth	
Gain	0 dB to 48 dB; 0.1 dB increments	
Digital binning <sup>1</sup>	Horizontal: 1 to 8 columns; Vertical: 1 to 8 rows	
Sensor binning (H × V)	2 × 2	Not applicable
Multiple ROI (H × V)	<i>Free</i>   <i>Tile</i>   <i>Horizontal</i> : 1 × 1 to 1 × 4   <i>Vertical</i> : 1 × 1 to 4 × 1	
Non-volatile memory (Flash)	1024 KByte	
Inputs and outputs	1 opto-isolated input, 1 opto-isolated output, 2 non-isolated GPIOs <sup>2</sup>	
Power requirements	12 to 24 VDC	
Power requirements (PoE)	IEEE 802.3af	
Power consumption (typical) <sup>3</sup>	External power: 4.0 W at 12 VDC Power over Ethernet: 4.4 W	
Storage temperature	-20 °C to +85 °C ambient temperature	
Operating temperature	-20 °C to +50 °C (Housing, typical), -20 °C to +85 °C (Mainboard <sup>3</sup> )	
Humidity	0% to 80% humidity (non-condensing)	
Digital interface	1000BASE-T	
Camera controls	GenICam (GenICam Access)	

<sup>1</sup> Digital vertical binning can be used only when digital horizontal binning is used as well.

<sup>2</sup> Use with external power only, not with PoE. See [I/Os and power supply by PoE](#) on page 38.

<sup>3</sup> Output by DeviceTemperature

Table 53: Alvium G1-2460m/c specifications

## Absolute QE

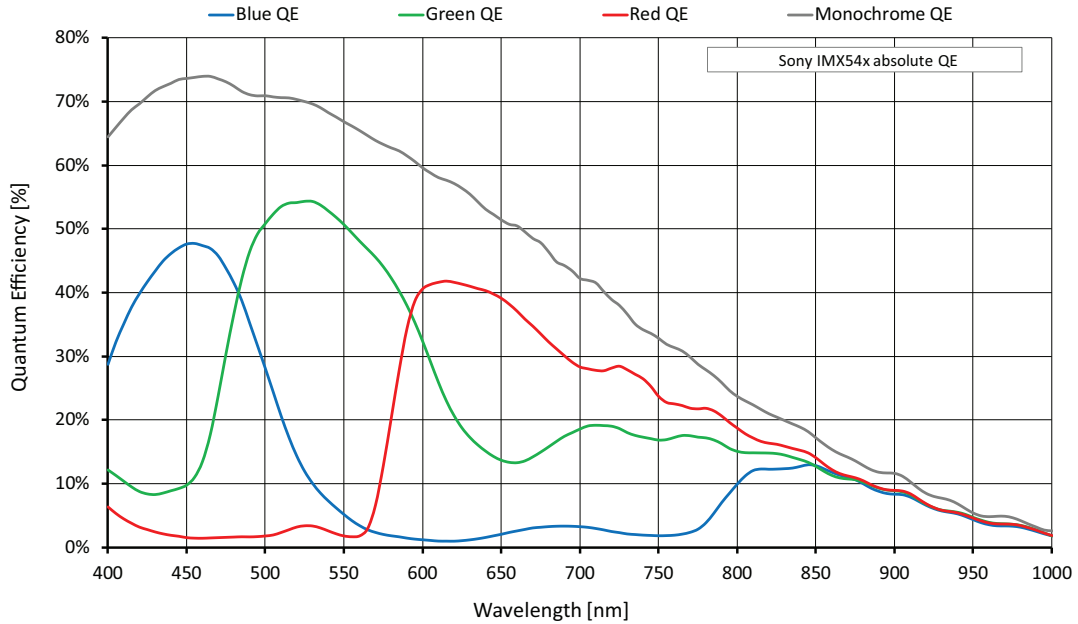

Figure 35: Alvium G1-2460m/c (Sony IMX540) absolute QE

## Spectral response

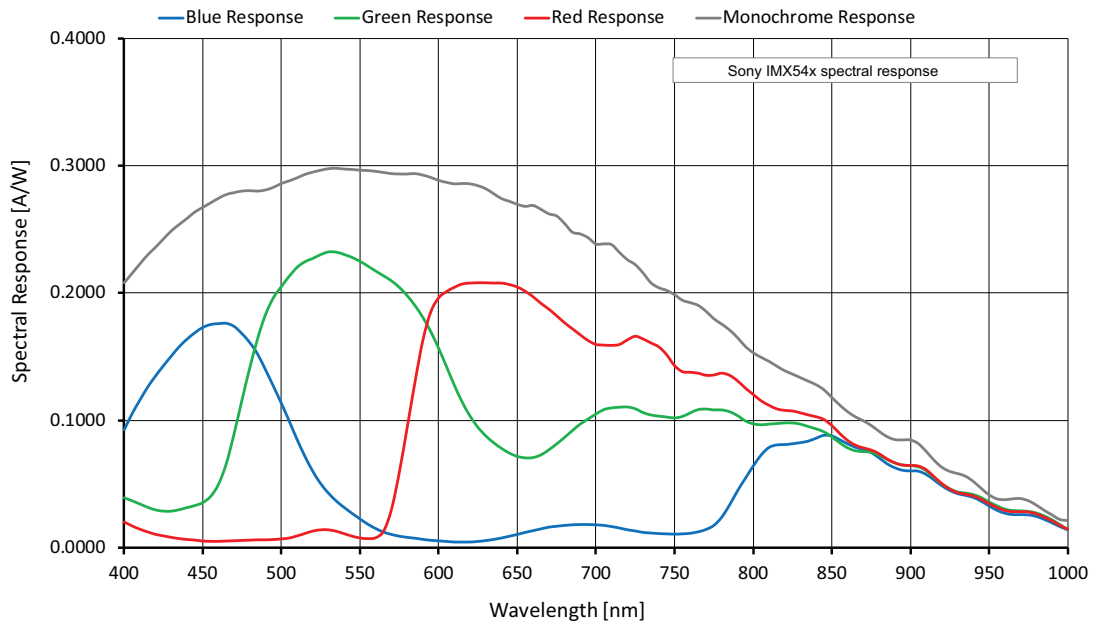

Figure 36: Alvium G1-2460m/c (Sony IMX540) spectral response

## ROI frame rates

Values are based on the conditions defined in [Specified values](#) on page 46.

Currently, Alvium G1-2460 models can be operated only at 122 MByte/s.

Image format	Width [pixels]	Height [pixels]	ROI area [MP]	Frame rate [fps] <sup>1</sup>
				122 MByte/s
Full resolution	5328	4608	24.551	4.8/2.4
HSXGA	5120	4096	20.972	5.6/2.8
HXGA	4096	3072	12.583	9.3/4.6
UHD 4K	3840	2160	8.294	13.8/6.9
QSXGA	2560	2048	5.243	21.9/11.0
WQHD	2560	1440	3.686	30.4/15.3
QXGA	2048	1536	3.146	35.8/18.0
Full HD	1920	1080	2.074	52.6/26.5
UXGA	1600	1200	1.920	52.5/28.8
WXGA+	1440	900	1.296	67.6/41.4
SXGA	1280	1024	1.311	60.7/41.6
HD 720	1280	720	0.922	82.6/56.7
XGA	1024	768	0.786	78.3/67.1
SVGA	800	600	0.480	96.9/96.9
VGA	640	480	0.307	116.6/116.6
HVGA	480	320	0.154	159.8/159.4
QVGA	320	240	0.077	195.8/195.8
HQVGA	240	160	0.038	252.8/252.8
QQVGA	160	120	0.019	295.8/295.8
Max. × half	5328	2304	12.276	9.4/4.7
Max. × min.	5328	8	0.043	171.9/91.6
Min. × max.	8	4608	0.037	14.7/14.7
Min. × min.	8	8	64 P	565.2/565.2

<sup>1</sup> Mono8 or Bayer...8<sup>(2)</sup> at SensorBitDepth = 10-Bit /  
 Mono10 or Bayer...10 at SensorBitDepth = 10-Bit

<sup>2</sup> The three dots... represent the colors of a Bayer pixel format, such as in BayerRG8.

Table 54: Alvium G1-2460m/c ROI frame rates

## White balance default

Alvium G1 color cameras are balanced for neutral color reproduction with an illumination of 5000 °K (warm daylight). [Table 55](#) shows default values for the red and blue channel by model.

For different illuminations, use auto white balance or adapt the color channel values manually.



### Feature descriptions and firmware downloads

Alvium Features Reference: [www.alliedvision.com/en/support/technical-documentation/alvium-gige-documentation](http://www.alliedvision.com/en/support/technical-documentation/alvium-gige-documentation)

Firmware downloads: [www.alliedvision.com/en/support/firmware-downloads](http://www.alliedvision.com/en/support/firmware-downloads).

Alvium G1 model	Sensor model	Red channel value	Blue channel value
Alvium G1-040c	Sony IMX287	2.360	2.030
Alvium G1-158c	Sony IMX273	2.355	2.100
Alvium G1-234c	Sony IMX249	2.580	1.810
Alvium G1-240c	Sony IMX392	2.355	2.100
Alvium G1-319c	Sony IMX265	2.355	2.100
Alvium G1-500c	ON Semiconductor AR0521SR	2.120	1.520
Alvium G1-507c	Sony IMX264	2.355	2.100
Alvium G1-510c	Sony IMX548	2.870	2.000
Alvium G1-811c	Sony IMX546	2.870	2.000
Alvium G1-1236c	Sony IMX304	2.355	2.100
Alvium G1-1240c	Sony IMX226	2.620	1.810
Alvium G1-1242c	Sony IMX545	2.870	2.000
Alvium G1-1620c	Sony IMX542	2.870	2.000
Alvium G1-2040c	Sony IMX541	2.870	2.000
Alvium G1-2050c	Sony IMX183	2.660	1.830
Alvium G1-2460c	Sony IMX540	2.870	2.000

*Table 55: Alvium G1 default values for color channels*



### Monochrome and VSWIR models

White balance default does not apply to monochrome and VSWIR models.

## Dimensions and mass

Feature	C-Mount	CS-Mount	S-Mount
Flange focal distance, optical [mm]	17.526	12.526	12.63
Thread [mm]	1"-32tpi UNS-2B	1"-32tpi UNS-2B	M12 × 0.5
Maximum protrusion <sup>1</sup> [mm]	13.6	8.6	11.0
Body dimensions (L × W × H [mm])	41 × 29 × 29	36 × 29 × 29	36 × 29 × 29
Mass	65 g	65 g	65 g

<sup>1</sup>For details, see [Lens mounts and maximum protrusion](#).

Table 56: Dimensions and mass

## Technical drawings

### C-Mount

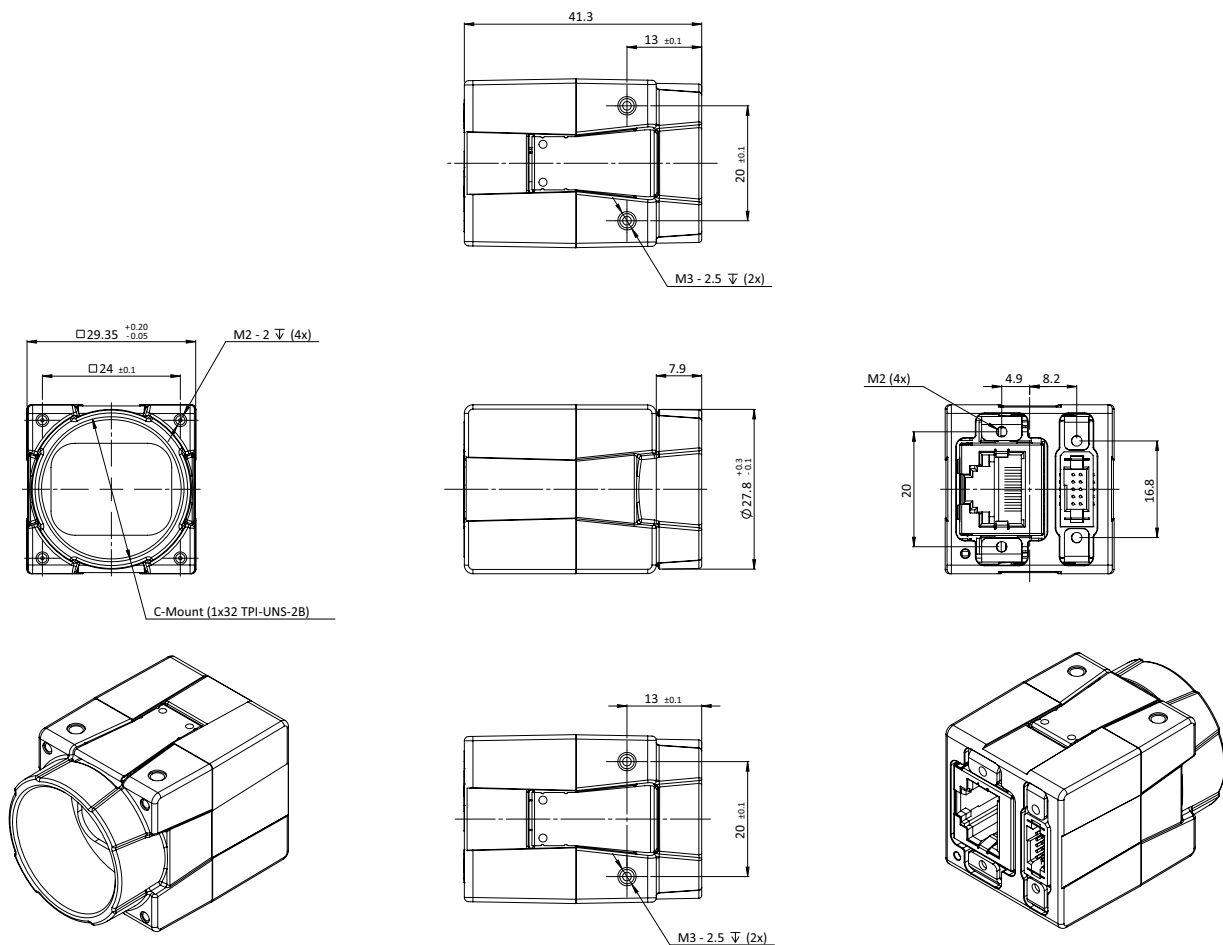

Figure 37: Dimensions for C-Mount models

## CS-Mount

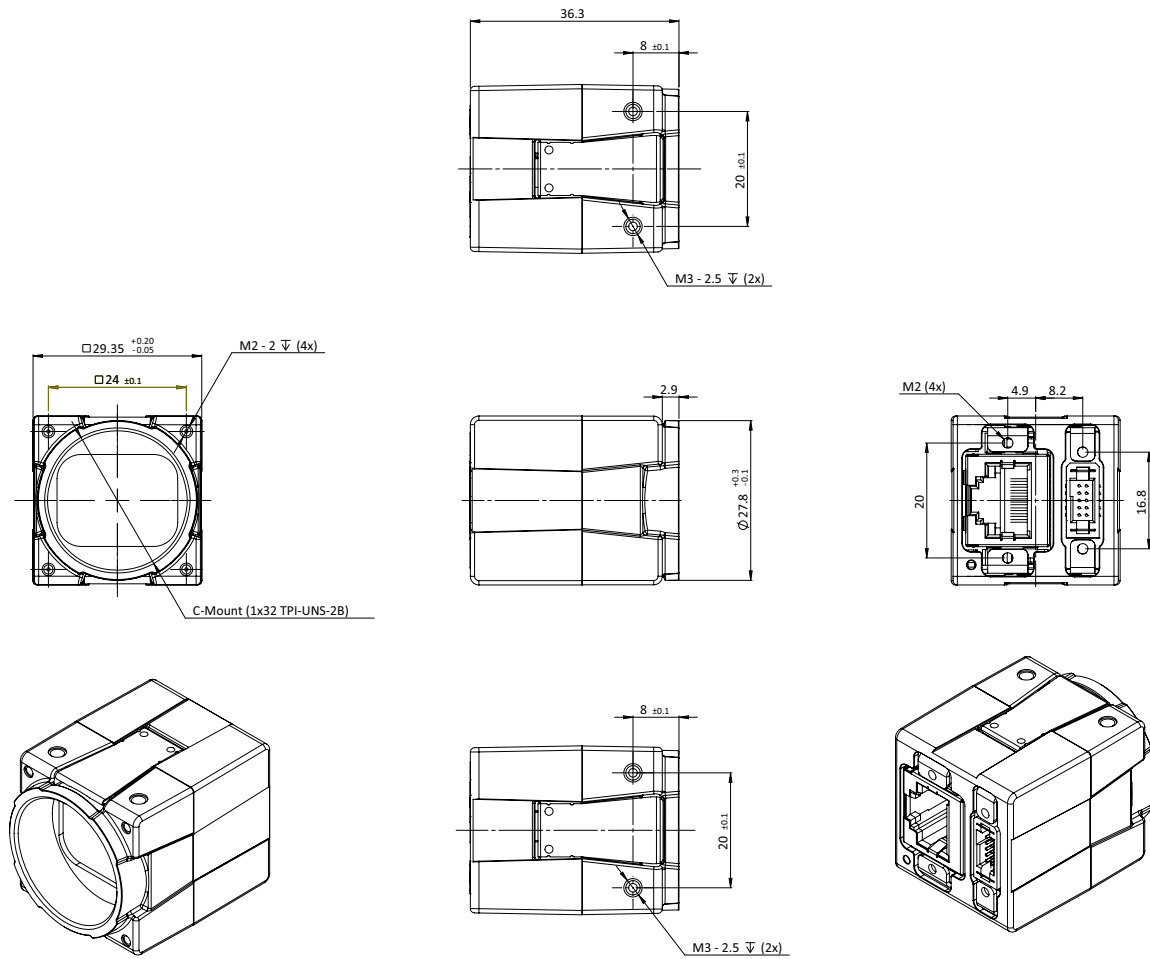

Figure 38: Dimensions for CS-Mount models

## S-Mount

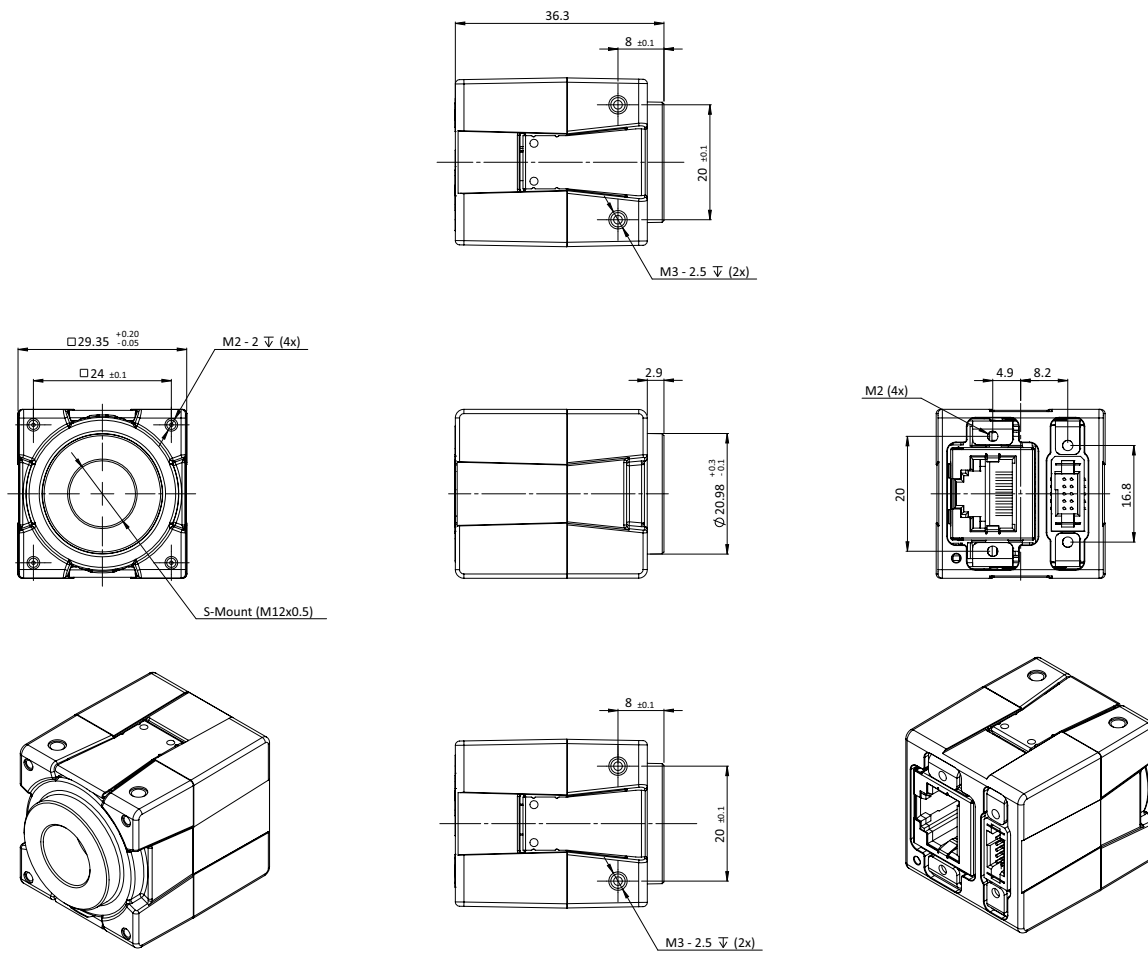

Figure 39: Dimensions for S-Mount models



# Lens mounts and maximum protrusion



### No need to readjust lens mounts

Alvium G1 camera mounts are adjusted with high precision during manufacturing. Construction ensures permanent accuracy without need to readjust.

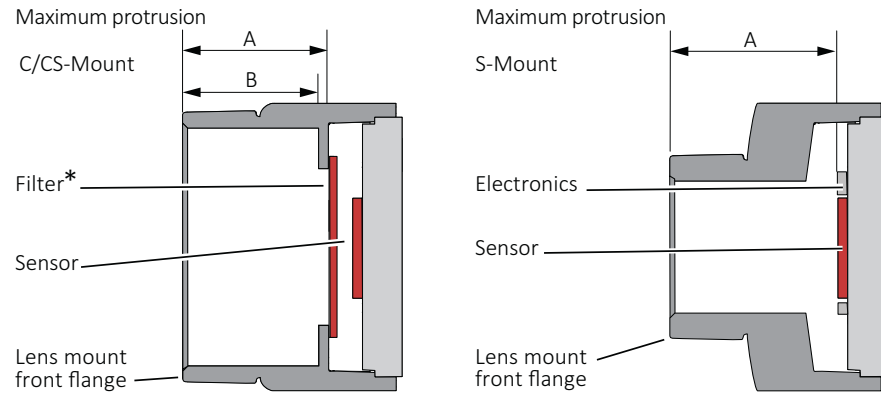

\*Only color models are equipped with an IR cut filter

Figure 40: Maximum protrusion C-Mount and CS-Mount (left); S-Mount (right)

Figure 40 shows schematics for maximum protrusion of lenses, Table 57 shows values for maximum protrusion.



### NOTICE

#### Damage to sensor or optics by unsuitable lenses

The sensor, filter, or lens can be damaged if a lens exceeding maximum protrusion is mounted to the camera.

- Use lenses with less than the allowed maximum protrusion, see Table 57.
- See [Mounting the lens](#) on page 136.
- For S-Mount lenses, see [Mounting and focusing S-Mount lenses](#) on page 137.

Mount	Maximum protrusion
C-Mount	13.6 mm
CS-Mount	8.6 mm
S-Mount	11.0 mm

Table 57: Maximum protrusion for Alvium G1 cameras

# IR cut filter

The following table shows which Alvium G1 models are equipped with an IR cut filter. The filter is permanently installed and cannot be removed.

Color or monochrome model	C-Mount CS-Mount	S-Mount
Color	Type Hoya C5000 IR cut filter	No filter
Monochrome	No filter	

Table 58: Optical filters availability

Cameras **without** IR cut filter have a higher sensitivity for low-light imaging. Moreover, spectral sensitivity is increased.

Cameras **with** IR cut filter are more accurate in reproduction of color, contrast, and sharpness, as the filter absorbs near-IR wavelengths. See [Figure 41](#) for filter transmission.



### Spectral transmission values

The following curve shows typical transmission for type Hoya C5000 IR cut filter. Values may vary slightly by filter lot.

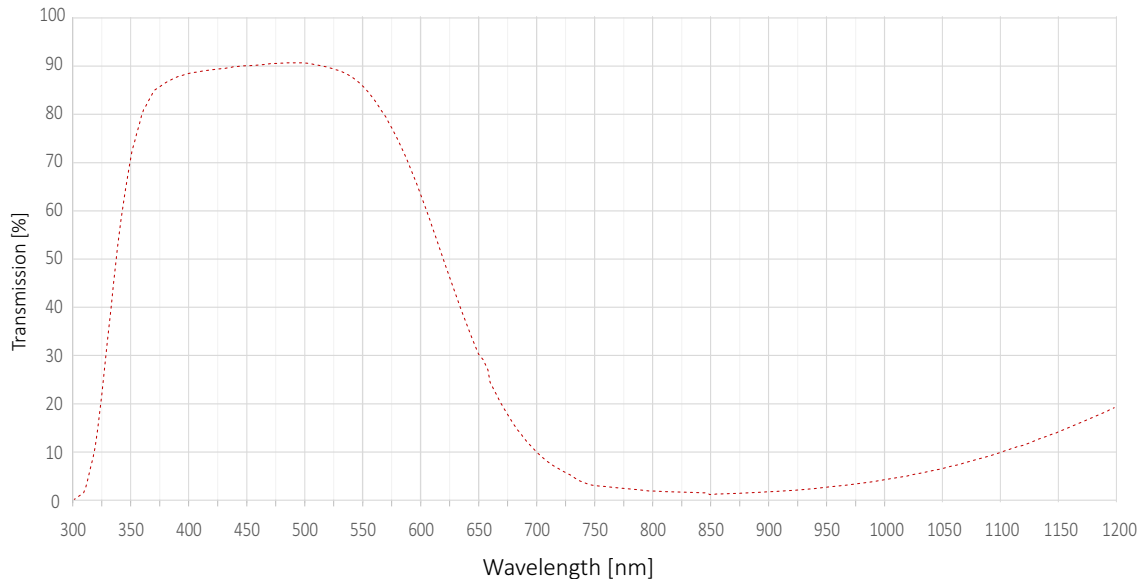

Figure 41: Spectral transmission for type Hoya C5000 IR cut filter (exemplary curve)



### S-Mount lenses with IR cut design

For improved image quality, we recommend using S-Mount lenses that are IR- optimized or that have IR cut coating. See the S-Mount Lenses User Guide at [www.alliedvision.com/fileadmin/content/documents/products/accessories/lenses/Allied\\_Vision/User\\_Guide/S-Mount-Lenses\\_User-Guide.pdf](http://www.alliedvision.com/fileadmin/content/documents/products/accessories/lenses/Allied_Vision/User_Guide/S-Mount-Lenses_User-Guide.pdf).

# Sensor position accuracy

## Sensor shift and rotation

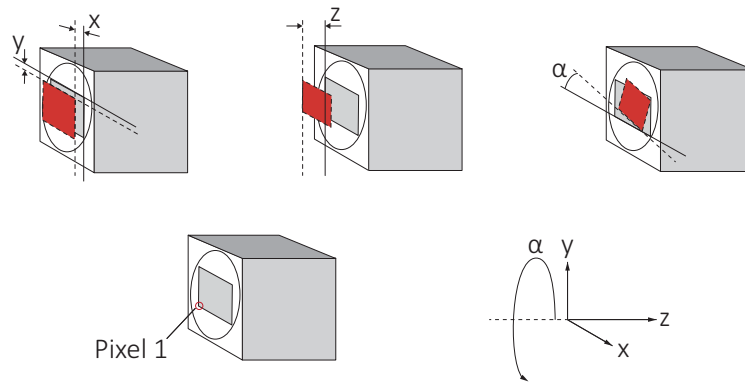

**Gray rectangle:** Reference sensor position    **Red rectangle:** Current position  
**Straight line:** Reference edge    **Dotted line:** Current reference edge

The orientation of the z-axis deviates from scientific conventions to define tolerances of the flange focal distance.

Figure 42: Sensor shift and rotation

The following table defines the manufacturing accuracy for sensor positioning of Alvium G1 cameras.

Criteria	Subject	Properties
Alignment method		Optical alignment of the photosensitive sensor area into the camera front module (lens mount front flange)
Reference Points	Sensor	Center of the pixel area (photo sensitive cells)
	Camera	Center of the lens mount
Accuracy	x/y-axis <sup>1</sup>	±150 µm (sensor shift)
	z	0 to -100 µm (optical back focal length)
	α <sup>1</sup>	±0.5 deg (sensor rotation as the deviation from the parallel to the camera bottom)

<sup>1</sup> We cannot measure or guarantee these values for S-Mount hardware options that are manufactured on customer request for: Alvium G1-234, G1-507, G1-811, G1-812 UV, G1-1236, G1-1242, G1-1620, G1-2040, G1-2050, and G1-2460.

Table 59: Alvium G1 cameras, criteria of sensor position accuracy

## Sensor tilt

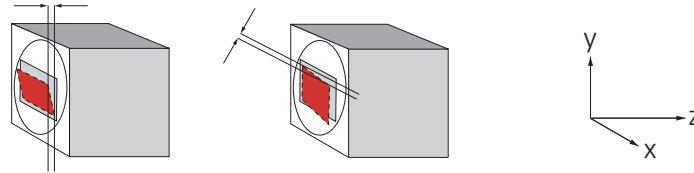

**Gray rectangle:** Reference sensor position     **Red rectangle:** Current position

Figure 43: Sensor tilt

The following table defines sensor tilt as the variance between highest and lowest pixel of a sensor along the z-axis, measured in micrometers..

Alvium G1 model	Pixel size	Maximum tilt
Alvium G1-030 VSWIR	5 $\mu\text{m}$ $\times$ 5 $\mu\text{m}$	50 $\mu\text{m}$
Alvium G1-040m/c	6.9 $\mu\text{m}$ $\times$ 6.9 $\mu\text{m}$	95 $\mu\text{m}$
Alvium G1-130 VSWIR	5 $\mu\text{m}$ $\times$ 5 $\mu\text{m}$	50 $\mu\text{m}$
Alvium G1-158m/c	3.45 $\mu\text{m}$ $\times$ 3.45 $\mu\text{m}$	24 $\mu\text{m}$
Alvium G1-234m/c	5.86 $\mu\text{m}$ $\times$ 5.86 $\mu\text{m}$	69 $\mu\text{m}$
Alvium G1-240m/c	3.45 $\mu\text{m}$ $\times$ 3.45 $\mu\text{m}$	24 $\mu\text{m}$
Alvium G1-319m/c	3.45 $\mu\text{m}$ $\times$ 3.45 $\mu\text{m}$	24 $\mu\text{m}$
Alvium G1-500m/c	2.2 $\mu\text{m}$ $\times$ 2.2 $\mu\text{m}$	15 $\mu\text{m}$
Alvium G1-507m/c	3.45 $\mu\text{m}$ $\times$ 3.45 $\mu\text{m}$	24 $\mu\text{m}$
Alvium G1-510m/c	2.74 $\mu\text{m}$ $\times$ 2.74 $\mu\text{m}$	18 $\mu\text{m}$
Alvium G1-811m/c	2.74 $\mu\text{m}$ $\times$ 2.74 $\mu\text{m}$	18 $\mu\text{m}$
Alvium G1-812 UV	2.74 $\mu\text{m}$ $\times$ 2.74 $\mu\text{m}$	15 $\mu\text{m}$
Alvium G1-1236m/c	3.45 $\mu\text{m}$ $\times$ 3.45 $\mu\text{m}$	24 $\mu\text{m}$
Alvium G1-1240m/c	1.85 $\mu\text{m}$ $\times$ 1.85 $\mu\text{m}$	12 $\mu\text{m}$
Alvium G1-1242m/c	2.74 $\mu\text{m}$ $\times$ 2.74 $\mu\text{m}$	18 $\mu\text{m}$
Alvium G1-1620m/c	2.74 $\mu\text{m}$ $\times$ 2.74 $\mu\text{m}$	18 $\mu\text{m}$
Alvium G1-2040m/c	2.74 $\mu\text{m}$ $\times$ 2.74 $\mu\text{m}$	18 $\mu\text{m}$
Alvium G1-2050m/c	2.4 $\mu\text{m}$ $\times$ 2.4 $\mu\text{m}$	12 $\mu\text{m}$
Alvium G1-2460m/c	2.74 $\mu\text{m}$ $\times$ 2.74 $\mu\text{m}$	18 $\mu\text{m}$

Table 60: Sensor tilt

# User sets

## Supported features

UserSet features enable to store individual settings on Alvium G1 cameras. These user sets can be loaded by default, without needing to set values by software after every restart of the camera. Or they can be used to switch between different settings, for example, to adjust from daylight to artificial light.

User sets on Alvium G1 cameras support all features except for:

- Selectors
- Command features
- Read-only features
- Features in the LUTControl category.

## Trigger features and UserSetDefault

Trigger features are reset to default values when the default user set is loaded.

- Column **UserSetLoad** displays how user values are affected when the command for **UserSetLoad** is executed.
- Column **DeviceReset** displays how user values are affected when the command for **DeviceReset** is executed.

Feature	Default value	UserSetDefault	DeviceReset
TriggerActivation	<i>RisingEdge</i>	Default value	Default value
TriggerMode	<i>Off</i>	Default value	Default value
TriggerSelector	<i>AcquisitionStart</i>	User value	Default value
TriggerSoftware	[Command]	Not applicable	Not applicable
TriggerSource	<i>Software</i>	Default value	Default value

Table 61: Trigger features being reset

## Camera feature availability

Alvium G1 cameras support a number of standard and extended features. The following tables compare the availability of selected features by model.



### Feature descriptions and firmware downloads

Alvium Features Reference: [www.alliedvision.com/en/support/technical-documentation/alvium-gige-documentation](http://www.alliedvision.com/en/support/technical-documentation/alvium-gige-documentation)

Firmware downloads: [www.alliedvision.com/en/support/firmware-downloads](http://www.alliedvision.com/en/support/firmware-downloads).

Image control	Monochrome models	Color models	Supported models
Adaptive noise correction	✓	✓	All
Auto exposure	✓	✓	All
Auto gain	✓	✓	All
Auto white balance	-	✓	All
Color transformation (including hue, saturation)	-	✓	All
Contrast	✓	✓	All
Custom convolution	✓	✓	All
De-Bayering up to 5x5	-	✓	All
<b>Digital</b> binning	✓	✓	All
DPC (defect pixel correction)	✓	✓	All
FPNC (fixed pattern noise correction)	✓	✓	All, <b>except</b> for: G1-030 VSWIR, -130 VSWIR, -2050
Gamma	✓	✓	All
Look up table (LUT)	✓	✓	All
<b>Multiple</b> ROI (regions of interest)	✓	✓	All, <b>except</b> for: G1-500, -1240, -2050
Reverse X/Y	✓	✓	All
<b>Sensor</b> binning	✓	-	G1-500, -510, -811, -812 UV, -1242, -1620, -2040, -2460
Sharpness/Blur	✓	✓	All
<b>Single</b> ROI (region of interest)	✓	✓	All

Table 62: Image control features by Alvium G1 model

Camera control	Monochrome models	Color models	Supported models
Acquisition frame rate	✓	✓	All
Bandwidth control (DeviceLinkThroughputLimit)	✓	✓	All
Burst mode (TransferControl1 features)	✓	✓	All
Counters and timers	✓	✓	All
Firmware update in the field	✓	✓	All
I/O and trigger control	✓	✓	All
Readout modes (SensorBitDepth)	✓	✓	G1-030 VSWIR, -040, -130 VSWIR, -158, -234, -240
Sequencer	✓	✓	All, <b>except</b> for: G1 -500, -1240, -2050
Serial I/Os	✓	✓	All
Temperature monitoring (mainboard, companion board, interface board)	✓	✓	All
User sets	✓	✓	All

Table 63: Camera control features by Alvium G1 model

# Lenses: Focal length vs. field of view

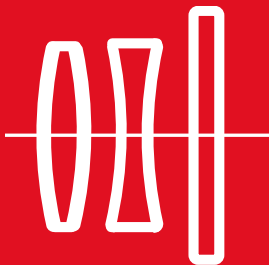

This chapter includes:

About this chapter .....	121
Optical vignetting with certain lenses .....	121
About S-Mount lenses .....	122
Focal length versus field of view .....	122



## About this chapter

This section presents tables that list selected fields of view (FOV) depending on sensor size, distance, and focal length of the lens.

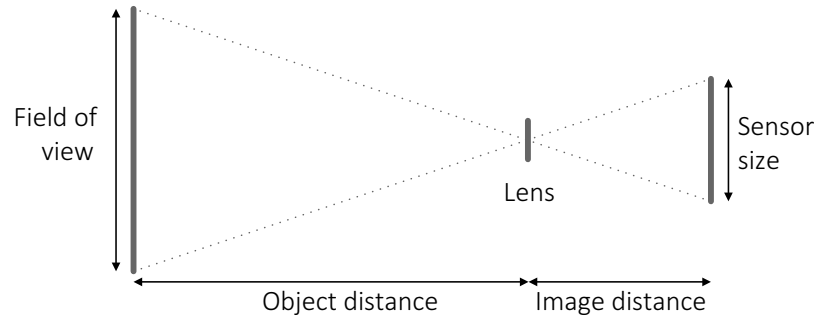

Figure 44: Parameters used in tables for focal length versus FOV



### Allied Vision S-Mount lenses

For technical data of Allied Vision S-Mount lenses with dedicated operating instructions, see the S-Mount Lenses User Guide at

[www.alliedvision.com/fileadmin/content/documents/products/accessories/lenses/Allied\\_Vision/User\\_Guide/S-Mount-Lenses\\_User-Guide.pdf](http://www.alliedvision.com/fileadmin/content/documents/products/accessories/lenses/Allied_Vision/User_Guide/S-Mount-Lenses_User-Guide.pdf).

## Parameters in tables

The distance to the object is measured from the first principal the plane of the lens to the object. For some lenses, manufacturers do not define the principal plane position. Production spread causes tolerances for all values, including actual focal lengths. Calculations apply for image reproduction without distortion. Therefore, values do not apply for fisheye lenses.

Please ask your Allied Vision Sales representative in case you need more information.

## Optical vignetting with certain lenses

Lenses with short focal lengths may show optical vignetting at the edges of the image. Microlenses on the sensor pixels can increase the effect.

For demanding applications, we suggest testing camera and lens to find a suitable setup. If you have questions, please contact your Allied Vision Sales representative.

## About S-Mount lenses

Alvium G1 S-Mount models have no filter. We recommend using S-Mount lenses with an integrated IR-cut filter for a better image quality.

Read [Mounting and focusing S-Mount lenses](#) on page 137 to avoid damage when using S-Mount lenses.

## Focal length versus field of view

### Alvium G1-030 VSWIR

Values for G1-030 VSWIR cameras with Type 1/4 (4.1 mm diagonal) sensors:

Focal length [mm]	Field of view (H × V [mm])	
	Object distance = 500 mm	Object distance = 1000 mm
4	407 × 322	817 × 647
5	775 × 773	1557 × 1553
6	644 × 642	1296 × 1293
8	481 × 480	970 × 968
12	318 × 317	644 × 642
16	237 × 236	481 × 480
25	149 × 148	305 × 304
35	104 × 104	216 × 215
50	70 × 70	149 × 148

Table 64: Focal length versus field of view for Alvium G1-030 VSWIR

## Alvium G1-040m/c

Values for G1-040m/c cameras with Type 1/2.9 (6.3 mm diagonal) sensors:

Focal length [mm]	Field of view (H × V [mm])	
	Object distance = 500 mm	Object distance = 1000 mm
2.8	892 × 667	1789 × 1337
3.6	693 × 518	1390 × 1039
4.8	518 × 387	1041 × 778
6	414 × 309	832 × 622
8	309 × 231	623 × 465
12	204 × 153	414 × 309
16	152 × 114	309 × 231
25	95 × 71	196 × 146

Table 65: Focal length versus field of view for Alvium G1-040m/c

## Alvium G1-130 VSWIR

Values for G1-130 VSWIR cameras with Type 1/2 (8.2 mm diagonal) sensors:

Focal length [mm]	Field of view (H × V [mm])	
	Object distance = 500 mm	Object distance = 1000 mm
5	671 × 560	1348 × 1125
6	558 × 466	1122 × 937
8	417 × 348	840 × 701
12	275 × 230	558 × 466
16	205 × 171	417 × 348
25	129 × 107	264 × 221
35	90 × 75	187 × 156
50	61 × 51	129 × 107

Table 66: Focal length versus field of view for Alvium G1-130 VSWIR

## Alvium G1-158m/c

Values for G1-158m/c cameras with Type 1/2.9 (6.3 mm diagonal) sensors:

Focal length [mm]	Field of view (H × V [mm])	
	Object distance = 500 mm	Object distance = 1000 mm
2.8	892 × 667	1789 × 1337
3.6	693 × 518	1390 × 1039
4.8	518 × 387	1041 × 778
6	414 × 309	832 × 622
8	309 × 231	623 × 465
12	204 × 153	414 × 309
16	152 × 114	309 × 231
25	95 × 71	196 × 146

Table 67: Focal length versus field of view for Alvium G1-158m/c

## Alvium G1-234m/c

Values for G1-234m/c cameras with Type 1/1.2 (13.4 mm diagonal) sensors:

Focal length [mm]	Field of view (H × V in [mm])	
	Object distance = 500 mm	Object distance = 1000 mm
12 mm	461 × 290 mm	933 × 586 mm
16 mm	343 × 215 mm	697 × 438 mm
25 mm	215 × 135 mm	442 × 278 mm
35 mm	150 × 94 mm	312 × 196 mm
50 mm	102 × 64 mm	215 × 135 mm

Table 68: Focal length versus field of view for Alvium G1-234m/c

## Alvium G1-240m/c

Values for G1-240m/c cameras with Type 1/2.3 (7.9 mm diagonal) sensors:

Focal length [mm]	Field of view (H × V in [mm])	
	Object distance = 500 mm	Object distance = 1000 mm
4.8	691 × 433	1389 × 871
6	552 × 346	1110 × 696
8	412 × 258	831 × 521
12	272 × 171	552 × 346
16	203 × 127	412 × 258
25	127 × 80	261 × 164
35	89 × 56	185 × 116
50	60 × 38	127 × 80

Table 69: Focal length versus field of view for Alvium G1-240m/c

## Alvium G1-319m/c

Values for G1-319m/c cameras with Type 1/1.8 (8.9 mm diagonal) sensors:

Focal length [mm]	Field of view (H × V in [mm])	
	Object distance = 500 mm	Object distance = 1000 mm
4.8	735 × 550	1476 × 1104
6	586 × 439	1180 × 882
8	438 × 328	883 × 661
12	290 × 217	586 × 439
16	215 × 161	438 × 328
25	135 × 101	278 × 208
35	95 × 71	196 × 147
50	64 × 48	135 × 101

Table 70: Focal length versus field of view for Alvium G1-319m/c

## Alvium G1-500m/c

Values for G1-500m/c cameras with Type 1/2.5 (7.1 mm diagonal) sensors:

Focal length [mm]	Field of view (H × V in [mm])	
	Object distance = 500 mm	Object distance = 1000 mm
2.8	1013 × 759	2031 × 1523
3.6	786 × 590	1578 × 1184
4.8	588 × 441	1182 × 887
6	469 × 352	945 × 709
8	351 × 263	707 × 530
12	232 × 174	469 × 352
16	172 × 129	351 × 263
25	108 × 81	222 × 167

Table 71: Focal length versus field of view for Alvium G1-500m/c

## Alvium G1-507m/c

Values for G1-507m/c cameras Type 2/3 (11.1 mm diagonal) sensors:

Focal length [mm]	Field of view (H × V in [mm])	
	Object distance = 500 mm	Object distance = 1000 mm
6	700 × 584	1408 × 1175
8	523 × 436	1054 × 880
12	346 × 288	700 × 584
16	257 × 215	523 × 436
25	162 × 135	332 × 277
35	113 × 94	234 × 196
50	77 × 64	162 × 135

Table 72: Focal length versus field of view for Alvium G1-507m/c

## Alvium G1-510m/c

Values for G1-510m/c cameras with Type 1/1.8 (8.8 mm diagonal) sensors:

Focal length [mm]	Field of view (H × V in [mm])	
	Object distance = 500 mm	Object distance = 1000 mm
5	671 × 560	1348 × 1125
6	558 × 466	1122 × 937
8	417 × 348	840 × 701
12	275 × 230	558 × 466
16	205 × 171	417 × 348
25	129 × 107	264 × 221
35	90 × 75	187 × 156
50	61 × 51	129 × 107

Table 73: Focal length versus field of view for Alvium G1-510m/c

## Alvium G1-811m/c, G1-812 UV

Values for G1-811m/c and G1-812 UV cameras Type 2/3 (11 mm diagonal) sensors:

Focal length [mm]	Field of view (H × V in [mm])	
	Object distance = 500 mm	Object distance = 1000 mm
5	773 × 773	1553 × 1553
6	642 × 642	1293 × 1293
8	480 × 480	968 × 968
12	317 × 317	642 × 642
16	236 × 236	480 × 480
25	148 × 148	304 × 304
35	104 × 104	215 × 215
50	70 × 70	148 × 148

Table 74: Focal length versus field of view for Alvium G1-811m/c and G1-812 UV

## Alvium G1-1236m/c

Values for G1-1236m/c cameras with Type 1.1 (17.6 mm diagonal) sensors:

Focal length [mm]	Field of view (H × V in [mm])	
	Object distance = 500 mm	Object distance = 1000 mm
8	872 × 638	1759 × 1287
12	577 × 422	1168 × 854
16	429 × 314	872 × 638
25	270 × 197	553 × 405
35	188 × 138	391 × 286
50	128 × 93	270 × 197
75	80 × 59	175 × 128

Table 75: Focal length versus field of view for Alvium G1-1236m/c

## Alvium G1-1240m/c

Values for G1-1240m/c cameras with Type 1/1.7 (9.33 mm diagonal) sensors:

Focal length [mm]	Field of view (H × V in [mm])	
	Object distance = 500 mm	Object distance = 1000 mm
4.8	763 × 578	1534 × 1161
6	609 × 461	1226 × 928
8	455 × 344	918 × 694
12	301 × 228	609 × 461
16	224 × 169	455 × 344
25	141 × 106	289 × 218
35	98 × 74	204 × 154
50	67 × 50	141 × 106

Table 76: Focal length versus field of view for Alvium G1-1240m/c



## Alvium G1-1242m/c

Values for G1-1242m/c cameras with Type 1/1.1 (14 mm diagonal) sensors:

Focal length [mm]	Field of view (H × V in [mm])	
	Object distance = 500 mm	Object distance = 1000 mm
6	931 × 679	1874 × 1365
8	696 × 507	1403 × 1022
12	460 × 335	931 × 679
16	342 × 249	696 × 507
25	215 × 157	441 × 321
35	150 × 109	312 × 227
50	102 × 74	215 × 157
75	64 × 47	139 × 102

Table 77: Focal length versus field of view for Alvium G1-1242m/c

## Alvium G1-1620m/c

Values for G1-1620m/c cameras with Type 1.1 (16.8mm diagonal) sensors:

Focal length [mm]	Field of view (H × V in [mm])	
	Object distance = 500 mm	Object distance = 1000 mm
5	1445 × 825	2905 × 1658
6	1202 × 686	2419 × 1380
8	898 × 512	1810 × 1033
12	594 × 339	1202 × 686
16	442 × 252	898 × 512
25	277 × 158	569 × 325
35	194 × 111	403 × 230
50	131 × 75	277 × 158
75	83 × 47	180 × 103

Table 78: Focal length versus field of view for Alvium G1-1620m/c

## Alvium G1-2040m/c

Values for G1-2040m/c cameras with Type 1.1 (17.5 mm diagonal) sensors:

Focal length [mm]	Field of view (H × V in [mm])	
	Object distance = 500 mm	Object distance = 1000 mm
6	1018 × 1018	2048 × 2048
8	760 × 760	1533 × 1533
12	503 × 503	1018 × 1018
16	374 × 374	760 × 760
25	235 × 235	482 × 482
35	164 × 164	341 × 341
50	111 × 111	235 × 235
75	70 × 70	152 × 152
85	60 × 60	133 × 133

Table 79: Focal length versus field of view for Alvium G1-2040m/c

## Alvium G1-2050m/c

Values for G1-2050m/c cameras with Type 1 (15.86 mm diagonal) sensors:

Focal length [mm]	Field of view (H × V in [mm])	
	Object distance = 500 mm	Object distance = 1000 mm
8	811 × 542	1636 × 1093
12	536 × 358	1086 × 726
16	399 × 267	811 × 542
25	251 × 167	514 × 344
35	175 × 117	364 × 243
50	119 × 79	251 × 167
75	75 × 50	163 × 109
85	64 × 43	142 × 95
100	53 × 35	119 × 79

Table 80: Focal length versus field of view for Alvium G1-2050m/c

## Alvium G1-2460m/c

Values for G1-2460m/c cameras with Type 1.2 (19.3 mm diagonal) sensors:

Focal length [mm]	Field of view (H × V in [mm])	
	Object distance = 500 mm	Object distance = 1000 mm
8	898 × 776	1810 × 1566
12	594 × 513	1202 × 1040
16	442 × 382	898 × 776
25	277 × 240	569 × 492
35	194 × 168	403 × 348
50	131 × 114	277 × 240
75	83 × 72	180 × 156

*Table 81: Focal length versus field of view for Alvium G1-2460m/c*

# Installing the camera



This chapter includes:

Touching hot cameras .....	133
Usage of heat sinks .....	133
Mounting Alvium G1 cameras .....	134
Mounting the lens.....	136
Configuring the host computer .....	140
Connecting to the host computer .....	143
Powering up the camera.....	144

## Touching hot cameras



### CAUTION

#### Risk of burns

A camera in operation can reach temperature levels which could cause burns.

- Wear protective gloves when you touch a camera that is heated up.
- Ensure proper cooling of the camera.

Keep the operating temperature in the specified range to enable best image quality and to protect the camera from damage. In many cases, mounting the camera on a metal surface or using a lens will be sufficient to cool the camera effectively. However, especially when operated in higher ambient temperatures, additional measures for heat dissipation, such as using a heat sink, should be considered.

## Usage of heat sinks

Alvium G1 cameras can be operated without heat sinks in most applications. However, heat sinks can be used to reduce image noise and power consumption.



#### Automatic power off

If the mainboard temperature exceeds the specified maximum for more than two seconds, the camera is powered off automatically. Afterwards, you must power cycle the camera for restart. The current value for mainboard temperature is output by `DeviceTemperature`.



### NOTICE

#### Damage to the camera by heat sinks mounted improperly

Adhere to the instructions and safety notes provided by the manufacturer of the heat sink.



### NOTICE

#### Damage to the sensor, filter, and lens by corrosive substances

Some conductive media for heat sinks contain corrosive substances that can damage optical surfaces of the sensor, filter, and lens.

- Cover the optical path of the camera when you apply heat sink compound or adhesive to prevent substances and fumes from damaging optical surfaces.
- Adhere to the instructions and safety notes provided by the manufacturer of the conductive media.

# Mounting Alvium G1 cameras



## CAUTION

### Injury by falling cameras or lenses

A falling camera or lens can cause injury.

- Ensure proper mounting of cameras and lenses, especially for dynamic applications.
- Mount cameras as described in the instructions.
- Always make sure the mounting threads are intact.
- Fasten screws with maximum torque, using the entire thread engagement. For less thread engagement, see [Adapting maximum torque values](#) on page 135.
- We recommend you to apply thread locking.
- Use a lens support for heavy lenses.

## Bottom or top mounting

Especially for dynamic applications with high acceleration, mount the camera using the bottom mounting threads in addition.

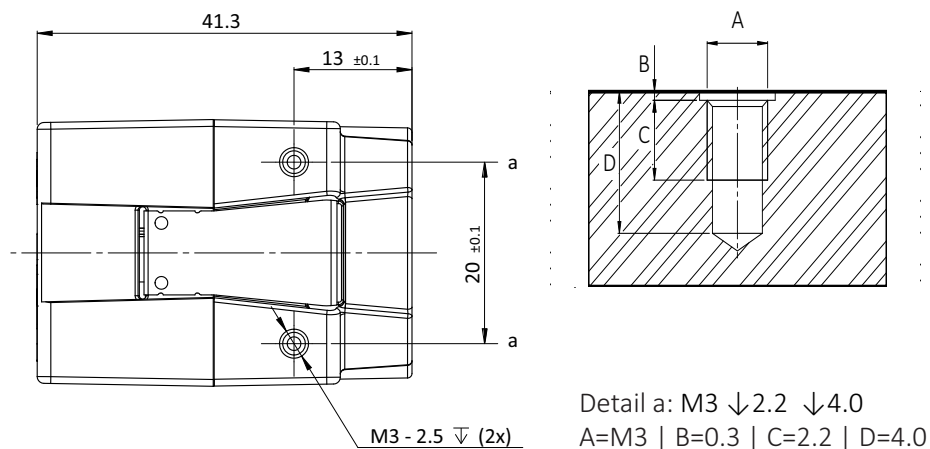

Figure 45: Mounting threads bottom and top (a)

**The maximum torque value applies only if the entire thread engagement is used.** For other values, see [Adapting maximum torque values](#) on page 135. For technical drawings, see [Dimensions and mass](#) on page 110.

1. As shown in [Figure 45](#), mount the camera to the base using suitable M3 screws for mounting thread a: At 0.51 Nm maximum torque for a thread engagement (C) of 2.2 mm between screws and mounting threads.
2. Continue with [Mounting the lens](#) on page 136.

## Front mounting

Especially for dynamic applications with high acceleration, mount the camera using the bottom mounting threads in addition.

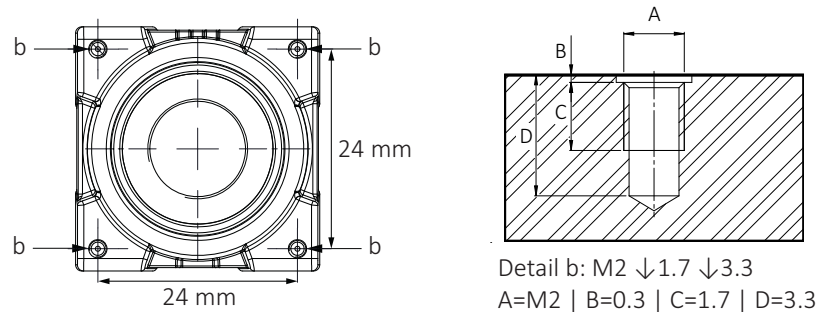

Figure 46: Camera front with mounting threads (c)

**The maximum torque value applies only if the entire thread engagement is used.** For other values, see [Adapting maximum torque values](#) on page 135.

1. Mount the camera to the base using suitable M2 screws at 0.17 Nm maximum torque for a thread engagement (C) of 1.7 mm between screws and mounting threads, see [Figure 46](#). For technical drawings, see [Dimensions and mass](#) on page 110.  
We recommend you to additionally use bottom and top mounting threads for a more solid connection.
2. Continue with [Mounting the lens](#) on page 136.

## Adapting maximum torque values

The total bolt length composes of the mounting holes length and the height of your mounting base.

For using less than the stated length of thread engagement, calculate maximum torque as follows:

$$\frac{\text{Current length of thread engagement}}{\text{Length of thread engagement in table}} \times \text{Torque in table} = \text{Current torque}$$

Example for a length of thread engagement of **1.4 mm** instead of 1.7 mm:

$$\mathbf{1.4\ mm} / 1.7\ \text{mm} \times 0.17\ \text{Nm} = \mathbf{0.14\ Nm}$$

Thread group	Thread position	Thread type	Total protrusion	Length of thread engagement	Maximum torque
b	Front mounting	M2	2 mm	1.7 mm	0.17 Nm
b	Front mounting	M2	2 mm	<b>1.4 mm</b>	<b>0.14 Nm</b>

Table 82: Adjusting maximum torque values

To ensure that the bolts do not become loose over time, we recommend you to use means for securing bolts, such as screw locking varnish.

**Tripod and mounting adapters**

See [www.alliedvision.com/en/support/accessory-documentation](http://www.alliedvision.com/en/support/accessory-documentation) for the

- **Alvium Tripod Adapter** used for all Alvium cameras
- **Alvium G1 Mounting Adapter**, using the same holes as Mako cameras to connect to mounting bases.

## Mounting the lens

Observe the following notes before you mount lenses to Alvium G1 cameras.

**CAUTION****Injury by falling cameras or lenses**

A falling camera or lens can cause injury.

- Ensure proper mounting of cameras and lenses, especially for dynamic applications.
- Mount cameras as described in the instructions.
- Use a lens support for heavy lenses.

**CAUTION****Risk of cuts by sharp edges of lens mounts**

The threads of the lens mount can have sharp edges.

Be careful when mounting or unmounting lenses.

**NOTICE****Damage to sensor or optics by unsuitable lenses**

The sensor, filter, or lens can be damaged if a lens exceeding maximum protrusion is mounted to the camera.

- Use lenses only up to the specified maximum protrusion.
- S-Mount lenses must be screwed into the camera less than maximum protrusion (11.0 mm).
- Avoid short S-Mount lenses falling into the camera.



## Mounting and focusing S-Mount lenses



### Allied Vision S-Mount lenses

For technical data of Allied Vision S-Mount lenses with dedicated operating instructions, see the S-Mount Lenses User Guide at [www.alliedvision.com/fileadmin/content/documents/products/accessories/lenses/Allied\\_Vision/User\\_Guide/S-Mount-Lenses\\_User-Guide.pdf](http://www.alliedvision.com/fileadmin/content/documents/products/accessories/lenses/Allied_Vision/User_Guide/S-Mount-Lenses_User-Guide.pdf).

This section instructs how to use S-Mount lenses with your camera safely. S-Mount lenses are screwed into the mount to adjust focus. Vibration moves lenses out of position. Several techniques can be used to fasten S-Mount lenses in focus. We recommend using fixing nuts. See instructions in this section.



### Drawings of cameras and fixing nuts

Drawings in the instructions are schematic.

Several manufacturers offer various types of S-Mount fixing nuts. The type shown in the instructions drawings is an example.

We recommend using pinch nose pliers to tighten fixing nuts.

Figure 47 shows how fixing nuts lock S-Mount lenses.  
Follow the instructions to lock the lens in focus position.

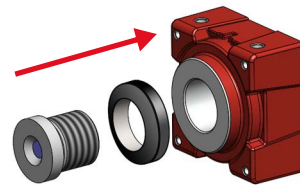

Figure 47: Fixing nut locking an S-Mount lens

**NOTICE**
**Damage to sensor or optics by improper handling**

If an S-Mount lens is screwed against the sensor, sensor and lens can be damaged.

- Screw in the lens at 11.0 mm maximum protrusion.
- Follow the instructions carefully.

**Determining the allowed range for the position of the lens**

1. Measure the length of the lens.
2. Calculate:  $a = c - b$   
 a: length of the mounted lens, measured from lens mount front flange  
 b: maximum protrusion (11.0 mm)  
 c: length of the lens

See [Lens mounts and maximum protrusion](#) on page 113.

3. Set a gauge to the length of (a).

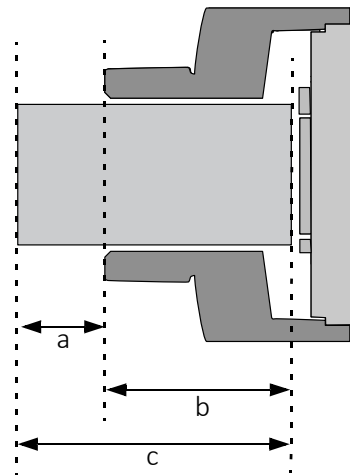

Figure 48: S-Mount lens and maximum protrusion

**Mounting the fixing nut to the lens**

4. Screw the fixing nut clockwise onto the lens until you can hold the front part (d) of the lens with your finger tips.



Figure 49: Lens and fixing nut

**Focusing the lens**

5. **Checking (a) with a gauge**, slowly screw the lens clockwise into the lens mount until the image is roughly in focus.
6. Slowly screw the lens in and out until you have found most accurate focus.

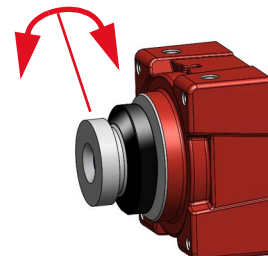

Figure 50: Adjusting focus

**NOTICE**
**Damage to lens threads and fixing nut by excessive force**

If the fixing nut is screwed with too much force, threads are worn out and the lens cannot be locked anymore.

Screw fixing nuts hand tight to keep the lens in a fixed position.

**Locking focus**

Pinch nose pliers are used to screw the fixing nut:

7. Holding the lens in position with one hand, screw the fixing nut clockwise against the lens mount until you feel the lens is locked.

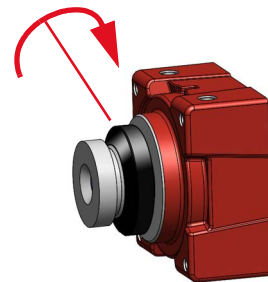

Figure 51: Tightening the fixing nut

**Checking focus is set and locked properly**

8. Check No.1: Try to rotate the lens with little strength in both directions to ensure the lens is safely locked in position.

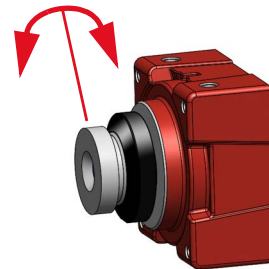

Figure 52: Checking lens is safely locked

9. Check No. 2: S-Mount thread allows a slightly tilted lens position. In this case, focus for a common object plane varies over the image plane.

**If focus is constant** over the image plane, you are done.

**If focus varies** over the image plane, the lens is tilted. Continue with [10](#).

10. Loosen the fixing nut.

11. Continue with [6](#).

The lens is locked in focus and ready for operation.

# Configuring the host computer



## Please consider...

Alvium G1 cameras require different hardware and settings than 1000BASE-T cameras like Mako or Prosilica GT cameras. We suggest you:

- Build up general knowledge: [Performance and troubleshooting](#) on page 166.
- Find solutions for issues: [Troubleshooting common issues](#) on page 182.

Alvium G1 cameras can operate on 100 and 1000BASE-T NICs. Requirements to reach the maximum camera frame rate:

- 1000BASE-T speed PCI Express NIC **on Desktop PCs**
- Jumbo Packet support for minimum 9,000 bytes. See [Enabling Jumbo Packets](#) on page 142.
- Enable Ethernet Flow Control on NICs and switches, see [NIC driver settings](#) on page 168.

Recommendations:

- Use only one camera per network port. For than one camera, use additional NICs or NICs with more than one port.
- Disable all unused NIC services and protocols (for example, activate only filter drivers for IPv4 and GigE).
- You can select between Fixed Link Speed and Auto Negotiation for the NIC driver's link speed settings.
  - **Fixed Link Speed:** If you set a link speed not supported by the camera, the link is not negotiated. Alvium G1 cameras support 1 Gbit/s for full performance or 100 Mbit/s for host systems that do not support 1 Gbit/s.
  - **Auto Negotiation:** We recommend using Auto Negotiation. The maximum link speed supported by the host system and the camera is set automatically. Therefore, the common link speed for the camera and host system may be lower than the maximum supported link speed of one of the two.



## NOTICE

### Network security

If cameras are used on mixed-use networks (with printers, Internet, and email), the network security may be affected, the camera performance as well.

- Use cameras only in trusted networks as required by the GigE Vision protocol.
- Check with your network administrator if required for network configuration.

## Installing the NIC driver

Install the NIC driver from your network card manufacturer if available. If no installation application is provided, update the driver manually.

## Linux: Updating the driver manually

Follow the instructions by the NIC manufacturer.

## Windows: Updating the driver manually

1. Open the **Device Manager** with administrator permission.
2. Under **Network Adapters**, locate the Ethernet network adapter, right-click the entry, and select **Update Driver Software** in the menu.
3. Select the **Search automatically for updated driver software or Browse my computer for driver software**.
4. Click **Close** after the driver has been installed.

## Modifying the NIC IP address

**This step is optional.**

After the initial NIC hardware installation, connect the NIC directly to the camera. The default configuration assigns an IP address automatically using the Link-Local Address range of 169.254.xxx.xxx or an address defined by the DHCP server, if present.

Users can fix the NIC address to minimize the time required for a camera to be recognized by the host application.

To connect to the camera, edit the host computer's adapter settings and configure the following settings:

- IP Address: 169.254.100.1
- Subnet mask: 255.255.0.0
- Default gateway: blank

When systems employ multiple NICs connected to multiple cameras the address of the NICs should be set. Each NIC or NIC card port requires a unique IP address.

For example:

NIC 1:

- IP Address: 169.254.100.1
- Subnet mask: 255.255.0.0
- Default gateway: blank

NIC 2:

- IP Address: 169.254.100.2
- Subnet mask: 255.255.0.0
- Default gateway: blank

## Adjusting the NIC driver settings

The NIC should be adjusted to improve system performance when using Alvium G1 cameras. This is achieved by minimizing the CPU usage in order to avoid dropped or resent packets.

Edit the NIC driver properties according to the values in the following table. The names and availability of the properties listed may vary depending on

- NIC manufacturer
- Operating system
- Camera model.

Property	Value
Packet Size, Frame Size, Jumbo Packet, or Maximum Transmission Unit	Maximum value configurable
Interrupt moderation	Enable
Interrupt moderation rate	Start with NIC's default value and experiment with different setting if required
Receive buffers	Maximum value configurable

Table 83: NIC settings

### Default packet size

At startup, Alvium G1 cameras have a default packet size of 576 bytes on the device stream channel. This enables optimum backward compatibility when ancient network hardware is used or when the network packets are tunneled through other protocols. Consider, that this packet size creates a large overhead on the host, which does not allow the full throughput most likely.

### Enabling Jumbo Packets

We recommend you to increase the packet size to the maximum value supported by all parts of the system. The effective packet size should be at least around **9,000 bytes**. Configure the NIC settings as follows:

1. Open the **Device Manager** with administrator permission.
2. Under **Network Adapters**, locate the Ethernet network adapter, right-click the entry, and select **Properties** in the menu.
3. Adjust the corresponding settings to match the values required in [Table 83](#).



#### Easy adjustment of the packet size

We recommend using **Vimba X** to adjust the packet size on connected cameras. See the **Vimba X** documentation included in the download at [www.alliedvision.com/en/products/software/vimba-x-sdk](http://www.alliedvision.com/en/products/software/vimba-x-sdk).

## Connecting to the host computer

Use a Category 6 or higher rated Ethernet cable to connect the Alvium G1 camera to the NIC. Crossover cabling is not required but does work. The camera has circuitry to determine if a crossover cable is being used.



We recommend Category 6 (CAT6) or higher rated Ethernet cables for Alvium G1 cameras. A different rating may not sustain peak interface bandwidth; leading to lost connectivity or dropped frames coming from the camera.

After you have installed the **Vimba X**, including **Vimba X Viewer** or third-party application to your host computer, connect your Alvium G1 camera via an Ethernet cable. If your camera is not PoE powered, connect the TFM I/O cable to power the camera.

## Allied Vision software

Software packages provided by Allied Vision are free of charge and contain such as:

- Drivers
- SDK for camera control and image acquisition
- Examples based on the provided APIs of the SDK
- Documentation and release notes
- Viewer application to operate and configure the cameras



Download **Vimba X** from [www.alliedvision.com/en/products/software/vimba-x-sdk](http://www.alliedvision.com/en/products/software/vimba-x-sdk). After installing, documentation is located in the **Vimba X** program folder.

## Third-party software

In addition to the software provided by Allied Vision, there are numerous GigE Vision standard compliant third-party software options available. In general, third-party software provides increased functionality such as image processing and video recording.

Allied Vision's **Vimba X** is based on the GenICam standard. GenICam-based third-party software automatically connects with Vimba's transport layers.

Additionally, **Vimba 6.0** (or previous) includes the **Cognex Adapter** for **VisionPro**.

# Powering up the camera

## Powering the camera via I/O port

When cameras are powered by both the 10-pin TFM I/O port and by PoE, power by the I/O port is used.



### NOTICE

#### Damage to the camera electronics

- Use only DC power supplies that comply with the camera specifications and that have insulated cases.
- When using external power supplies, pay attention to the alignment marks on the 10-pin TFM connector and socket. Inserting the plug in the wrong orientation might cause damage to the camera electronics and peripherals.
- For all cable connections, use only shielded cables to avoid electromagnetic interference.



#### External power supply

For the 13870 10-pin TFM power supply, see [www.alliedvision.com/en/support/accessory-documentation](http://www.alliedvision.com/en/support/accessory-documentation).

## Powering the camera via PoE



### NOTICE

#### Damage to the camera or connected peripherals

Damage to the camera and connected peripherals can occur if PSE is not galvanically isolated from mains and other electrical connections towards the camera (other than Ethernet signals and shield ground).

- Only use IEEE802.3af/at compliant PSE equipment to power the camera via PoE.
- Ensure the PSE is galvanically isolated from mains and all other electrical connections towards the camera.

Please note the following when using PoE NICs and PoE injectors with Allied Vision PoE-capable Alvium G1 cameras:

Feature	Specification
Supported standard	IEEE 802.3af, Power Class 0
Cable category	We recommend you to use Category 6 cables for better performance.
PSE	Power Sourcing Equipment (PSE) must support data over all 4 pairs and must be rated for the intended link speed.

Table 84: Powering the camera via PoE



# Camera interfaces

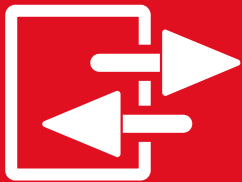

This chapter includes:

I/Os: Precautions .....	146
Back panel .....	147
I/O connector pin assignment .....	148
I/Os and GPIOs .....	149
Status LEDs .....	154

## I/Os: Precautions



### NOTICE

#### Damage to the camera or connected peripherals

The PoE implementation is non-isolated.

Therefore, when the camera is connected to a PoE-capable Ethernet port:

- Only connect the pins 3, 4, 5, 6 and 10 (isolated I/Os).
- **Do not** connect any other pins of the TFM connector.



### NOTICE

#### Damage by reverse polarity

If Alvium G1 cameras are externally powered with reverse polarity, the cameras can be damaged.

Power Alvium G1 cameras according to the specifications described in this chapter.



### NOTICE

#### Damage by serial communication voltage levels

If you are using serial communication (UART, similar to RS232), keep voltage levels in the range defined in [Table 86](#) on page 148. Typical RS232 voltage levels (such as  $\pm 10$  VDC) are not supported without external circuitry.



#### I/O cables maximum length

The maximum length for I/O cables must not exceed 30 m.



#### Signal level

Consider this when you connect external devices to your camera, for example, to trigger lighting:

- The default signal level for isolated GPO2 is low at camera startup.
- The default signal level for non-isolated GPIO0 and GPIO1 is high at camera startup.

Use the `LineInverter` feature to configure I/Os and GPIOs for your needs.

## Back panel

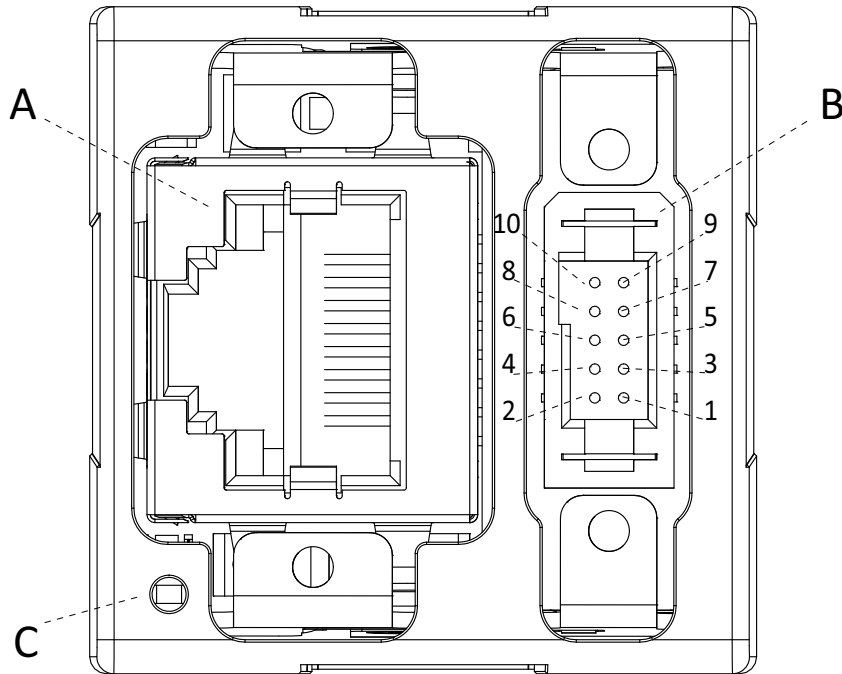

Figure 53: Back panel of camera

	Description
A	Ethernet port
B	I/O connector
C	LED

Table 85: Ports and LED



### I/O connector

The I/O connector is 10-pin TFM connector type is an TFM-105-02-L-D-WT-K-TR.

We recommend using cables by Allied Vision. If you are going to manufacture your own cables, see SFSD, ISDF, or SFM series at [www.samtec.com](http://www.samtec.com).



### I/O cables

For I/O cables at different lengths with 10 Pin TFM to open ends, see [www.alliedvision.com/en/support/accessory-documentation](http://www.alliedvision.com/en/support/accessory-documentation).

## I/O connector pin assignment

The general purpose I/O port uses a 10-pin TFM connector on the camera side.

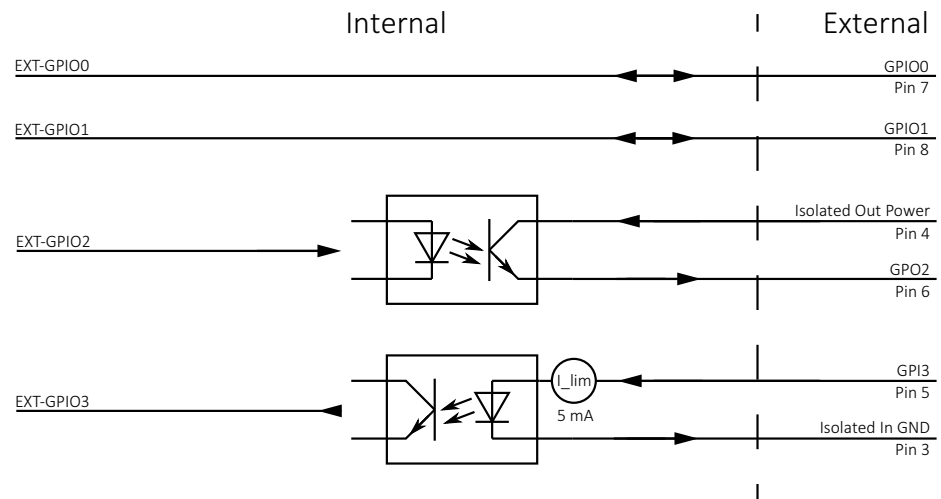

Figure 54: TFM I/O connector pin assignment

Pin	Signal	Direction	Level	Description
1	PWR-GND	In	0 VDC	Supply Ground
2	PWR-IN	In	10.8 to 26.4 VDC	Power supply voltage
3	OPTO-IN-GND	In	0 VDC	Isolated input ground
4	OPTO-OUT-PWR	In	max. 30 VDC	Power for isolated output
5	GPI3	In	$U_{in}(\text{high}) = 3.0 \text{ to } 24.0 \text{ V up to } 36 \text{ VDC}$ with $3.3 \text{ k}\Omega$ ext. resistor in series $U_{in}(\text{low}) = 0 \text{ to } 1.0 \text{ V}$	Isolated Input
6	GPO2	Out	Open emitter, max. 20 mA	Isolated Output
7	GPIO0	In/Out	$U_{in}(\text{low}) = -0.3 \text{ to } 0.8 \text{ VDC}$ $U_{in}(\text{high}) = 2.0 \text{ to } 5.5 \text{ VDC}$ $U_{out}(\text{low}) = 0 \text{ to } 0.4 \text{ VDC}$ $U_{out}(\text{high}) = 2.4 \text{ to } 3.3 \text{ VDC at max. } 20 \text{ mA}$	Non-isolated I/O (LVTTTL)
8	GPIO1	See Pin 7, GPIO0		
9	Reserved			
10	C-GND	PWR	0 VDC	Chassis ground and shielding

Table 86: TFM I/O connector pin assignment

## I/O use for UART

Table 87 shows which values must be selected to control I/Os using LineSelector.

Signal	LineSelector (GenICam)	UART line
EXT-GPIO 0	Line0	UART Tx
EXT-GPIO 1	Line1	UART Rx
EXT-GPIO 2	Line2	Not applicable
EXT-GPIO 3	Line3	Not applicable

Table 87: Value settings to control I/Os using the LineSelector feature



### Feature descriptions and firmware downloads

Alvium Features Reference: [www.alliedvision.com/en/support/technical-documentation/alvium-gige-documentation](http://www.alliedvision.com/en/support/technical-documentation/alvium-gige-documentation)

Firmware downloads: [www.alliedvision.com/en/support/firmware-downloads](http://www.alliedvision.com/en/support/firmware-downloads).

## I/Os and GPIOs

### Isolated input description

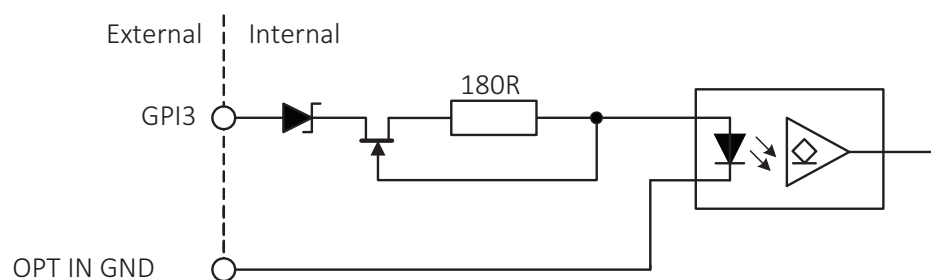

Figure 55: Input block diagram

The input can be connected directly to the system for voltages up to 24 VDC. An external resistor is not necessary.

## Levels

Parameter	Value
$U_{in}$ (low)	0 to 1.0 V
$U_{in}$ (high)	3 to 24 V
Current (constant-current source)	3 to 4 mA

Table 88: Input parameters

## Minimum pulse width

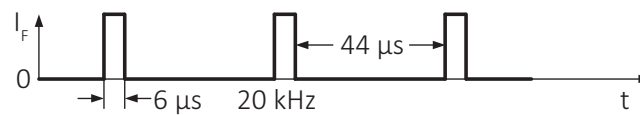

Figure 56: Minimum pulse width

## Test conditions

The input signal was driven with 3.3 V and no external additional series resistor.

## Isolated output description

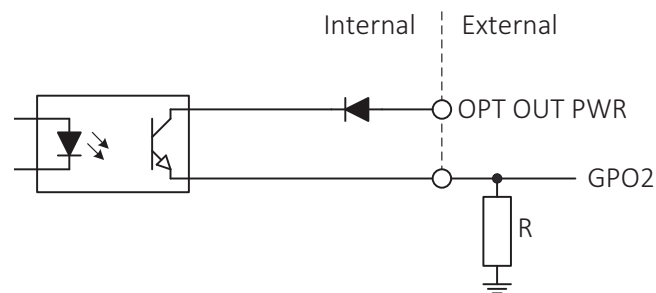

Figure 57: Output block diagram

## Levels



### NOTICE

#### Damage to the camera by high output current or voltage

Exceeding the maximum output voltage or current can damage the camera. Keep maximum output voltage below 24 VDC and output current below 20 mA.

Isolated out power	Resistor value <sup>1</sup>	
5 V	1.0 kΩ	at ~ 5 mA minimum required current draw
12 V	2.4 kΩ	
24 V	4.7 kΩ	

<sup>1</sup> A resistor is required when GPO2 is connected to a device with a high impedance < 5 mA draw.

Table 89: Isolated out power and external resistor

## Switching times

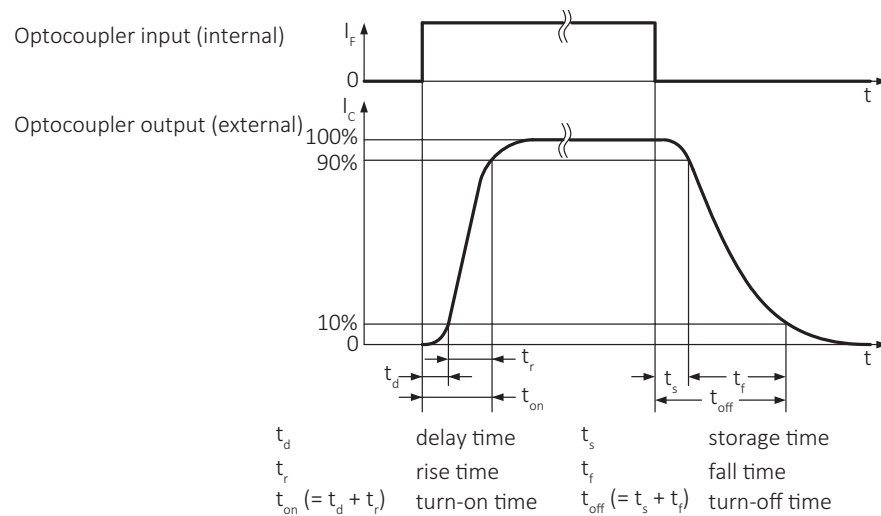

Figure 58: Output switching times

Parameter and value	
$t_d \approx 1 \mu\text{s}$	$t_s \approx 26 \mu\text{s}$
$t_r \approx 1 \mu\text{s}$	$t_f \approx 21 \mu\text{s}$
$t_{on} = t_d + t_r \approx 2 \mu\text{s}$	$t_{off} = t_s + t_f \approx 47 \mu\text{s}$ ( $t_{off}$ can deviate by $\pm 5 \mu\text{s}$ )

Table 90: Output parameters

### Test conditions

Output: external 2.4 kΩ resistor to GND, isolated out power set to 12 V.



Higher external values increase the times in the previous table.

## Non-isolated GPIOs description

The camera has two non-isolated GPIOs that can be configured by software to act as inputs or outputs.

Alvium G1 GPIOs use the push-pull technology to switch the signal level between low and high. For low levels, the signal is "pulled" down towards ground level. For high levels, the signal is "pushed" up towards VCC level.

Alvium G1 GPIOs feature the CMOS push-pull output drivers and Schmitt trigger inputs with an internal pull-up resistor and a filter circuit, shown in [Figure 59](#). The push-pull GPIOs are able to source or sink current from an external pin.

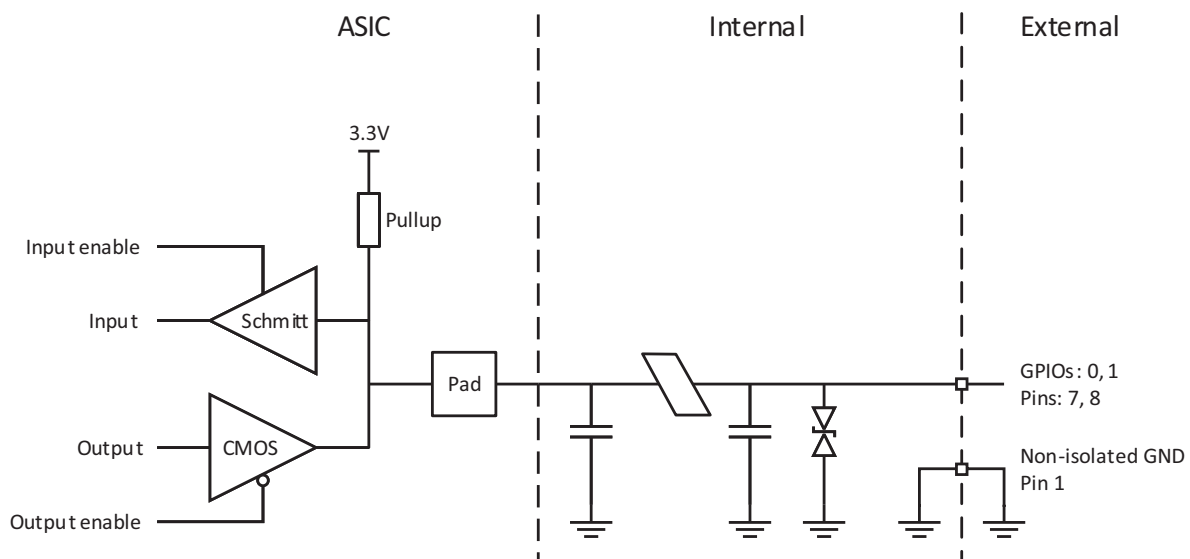

Figure 59: GPIOs block diagram



## Input levels

The GPIOs can be connected directly to the system controlling the camera for voltages up to 5.5 VDC. An external resistor is not necessary.



### NOTICE

#### Damage to the camera by high input voltage

Exceeding the maximum input voltage can damage the camera.  
Keep maximum input voltage below 5.5 VDC.

Parameter	Value
$U_{in}$ (low)	-0.3 to 0.8 VDC
$U_{in}$ (high)	2.0 to 5.5 VDC
Undefined levels	0.8 to 2.0 VDC

Table 91: GPIOs as input, voltage levels

## Output levels



### NOTICE

#### Damage to the camera by high output current

The camera can be damaged when connected to a device that exceeds the specified maximum current or voltage. Keep the maximum current below 12 mA per output.

Parameter	Value
External output voltage $U_{out}$ (low, Off state)	0 to 0.4 VDC
External output voltage $U_{out}$ (high, On state)	2.4 to 3.3 VDC
Undefined levels	0.4 to 2.4 VDC
Maximum external output voltage	3.3 VDC
Maximum output current	12 mA

Table 92: GPIOs as output, current and voltage levels



#### Output voltage for $U_{Out}$ (high) = On state

The voltage level in the On state depends on the load current. Higher currents yield lower voltage.

## Status LEDs

Alvium G1 cameras have LEDs to signal in yellow, green, or red color.



### LED settings

You can define LED settings with the `DeviceIndicatorLuminance` feature:

- A value of `10` enables LED signaling at the highest luminance level.
- Values below `10` reduce the luminance level.
- `0` disables LED signaling.

## LED codes



LED codes	Behavior	Status
	Continuously active	Camera is initializing
	1 flash per second	Camera is operational
	Continuously active	Error state

Table 93: LED codes



### Yellow LED color

With yellow, a green and a red LED are active in parallel. Seen directly from behind, this appears as yellow; seen from an angle, you can see green and red separately.

## Error state

If the camera signals an error, try the following to get the camera back to normal operation:

- Restart the camera.
- Should this fail, please contact support at [www.alliedvision.com/en/about-us/contact-us/technical-support-repair/-rma](http://www.alliedvision.com/en/about-us/contact-us/technical-support-repair/-rma).

# Triggering and timings



This chapter includes:

Trigger signal flow .....	156
Trigger latency .....	156
Triggering with rolling shutter cameras .....	157

# Trigger signal flow

Figure 60 shows a general diagram for the trigger signal flow. The external signal can be a physical source, such as light barrier as hardware trigger or a software trigger. This external signal starts the exposure of a frame. The end of exposure starts the readout. High levels show the active state of a signal.



## Feature descriptions and firmware downloads

Alvium Features Reference: [www.alliedvision.com/en/support/technical-documentation/alvium-gige-documentation](http://www.alliedvision.com/en/support/technical-documentation/alvium-gige-documentation)

Firmware downloads: [www.alliedvision.com/en/support/firmware-downloads](http://www.alliedvision.com/en/support/firmware-downloads).

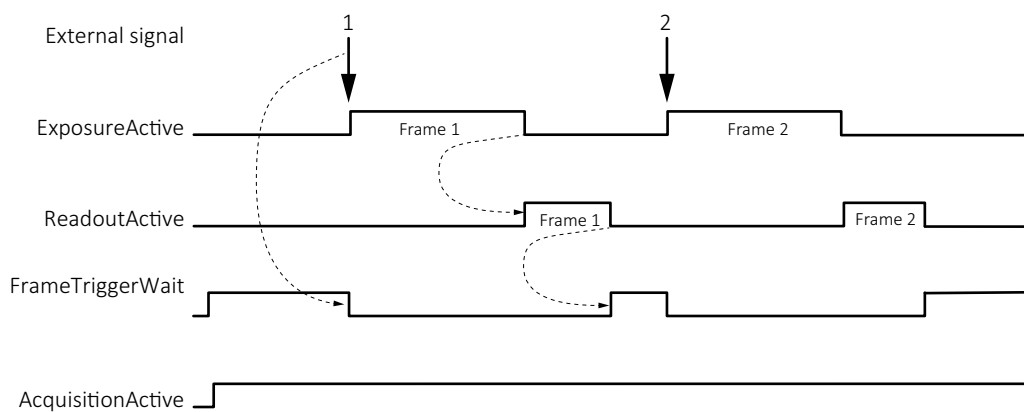

Figure 60: Schematic trigger signal flow

Term	Description
External signal	Electrical trigger signal starting the signal flow
<i>ExposureActive</i>	Exposing a frame
<i>ReadoutActive</i>	Reading out a frame
<i>FrameTriggerWait</i>	Waiting for a trigger
<i>AcquisitionActive</i>	Enables frame acquisition: Expose, read out data, or wait for triggers.

Table 94: Trigger signal flow terms

## Trigger latency

In theory, a trigger creates an immediate response of the camera, depending on the cable length. In practice, the computer may add a delay that is mostly unpredictable, especially on Windows systems. In addition, camera electronics and sensors have a delay.

We recommend you to trigger on the rising edge for the fastest reaction time.

Electronic rolling shutter (ERS) cameras in this document also have exposure delay, depending on camera settings, see [Triggering with rolling shutter cameras](#) on page 157. Electronic rolling shutter is commonly called rolling shutter.

# Triggering with rolling shutter cameras

This section describes triggering behavior for **Alvium G1-500m/c and G1-2050m/c** cameras with rolling shutter sensor. Figure 61 shows how an external signal triggers exposure and readout for cameras with rolling shutter sensors. Like for global shutter sensors, readout has a constant duration, acquisition must be active to enable exposure, the end of exposure starts readout.

ERS sensors run in cycles where **readout area** equals **exposure area**. Overlapping triggering is not supported. If exposure time is shorter than readout time, exposure starts with a delay:

$$\text{Exposure start delay} = \text{exposure area} - \text{exposure time.}$$

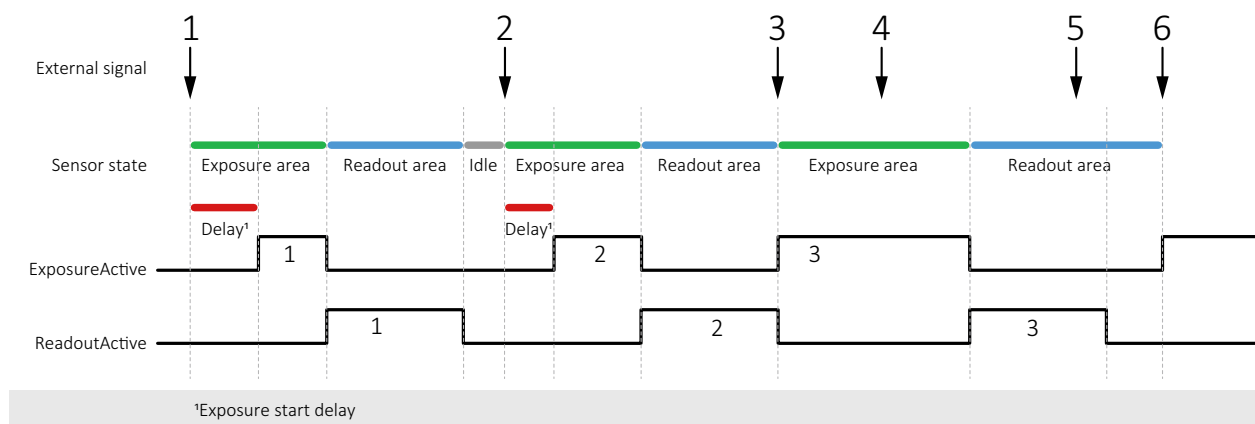

Figure 61: Triggering rolling shutter cameras

No	Conditions	Results
1	Exposure time is shorter than readout time.	Trigger 1 starts exposure 1 with a delay
2	Exposure time is shorter than readout time, but <b>longer</b> than for exposure 1.	Trigger 2 starts exposure 2 with a delay <b>shorter</b> than for exposure 1.
3	Exposure time is longer than readout time	Trigger 3 starts exposure time without a delay. Because the <b>exposure area</b> is longer, also the <b>readout area</b> is longer than for triggers 1 and 2
4	<b>Exposure area</b> is ongoing.	Trigger 4 is ignored.
5	<b>Readout area</b> is ongoing	Trigger 5 is ignored.
6	<b>Readout area</b> is finished. Exposure time is longer than readout time.	Trigger 6 starts exposure 6 without a delay

Table 95: Triggering results versus conditions



### TriggerSelector values for rolling shutter cameras

Cameras with rolling shutter **can** be triggered using *AcquisitionStart*, *AcquisitionEnd*, or *FrameStart* for **TriggerSelector**.

Cameras with rolling shutter **cannot** be triggered using *ExposureStart* or *ExposureEnd* for **TriggerSelector**.

## Ignored triggers

Alvium G1-500m/c, G1-1240m/c, and G1-2050m/c

Changing parameters while acquisition is active leads to ignored triggers until the parameters get active.

## Trigger features and UserSetDefault

See [Trigger features and UserSetDefault](#) on page 117.

# Image data flow



This chapter includes the image data flow for Alvium G1 cameras.

Figure 62 shows image data processing for Alvim G1 cameras in general.

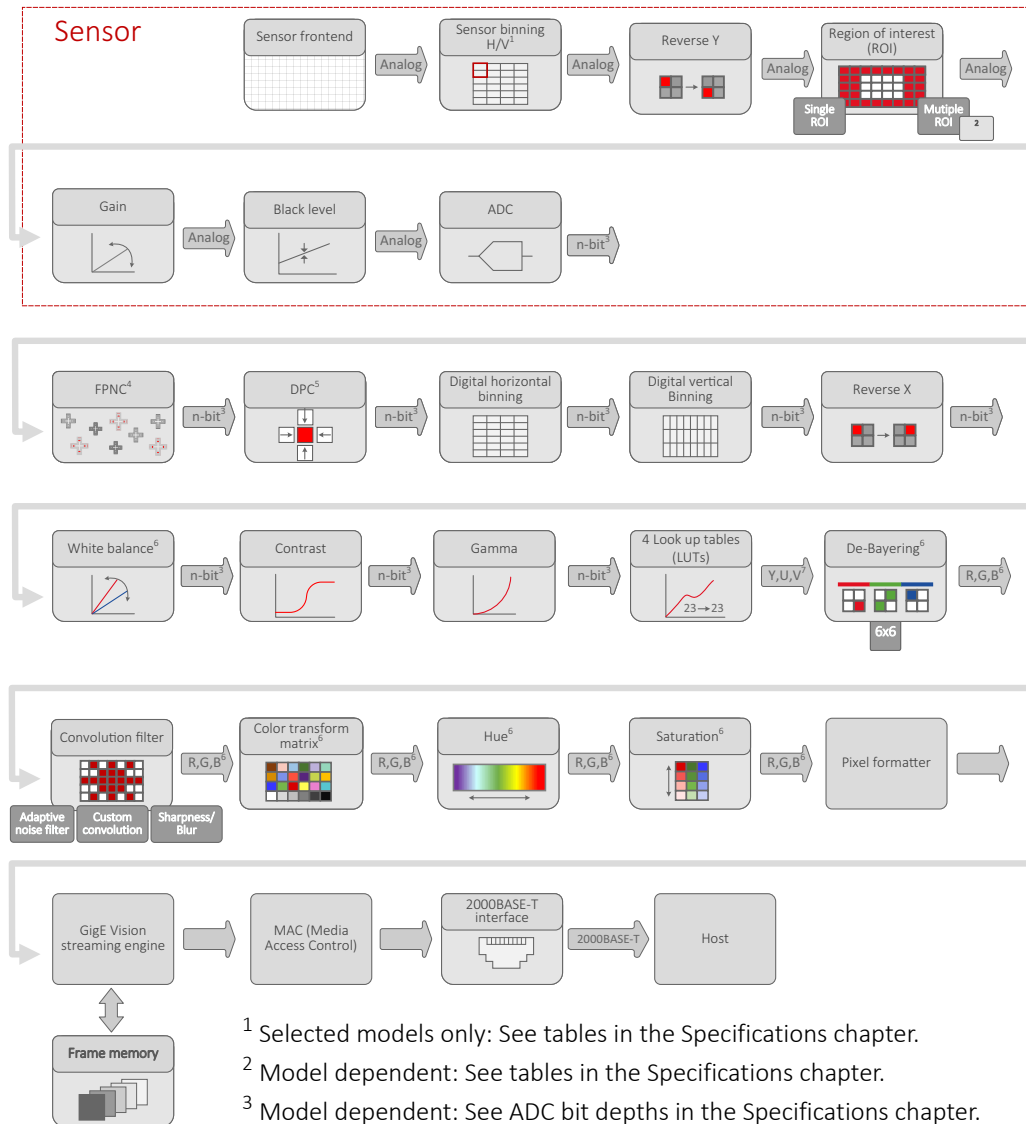

<sup>1</sup> Selected models only: See tables in the Specifications chapter.

<sup>2</sup> Model dependent: See tables in the Specifications chapter.

<sup>3</sup> Model dependent: See ADC bit depths in the Specifications chapter.

<sup>4</sup> Factory preset for FPNC = Fixed Pattern Noise Correction. FPNC is **currently not supported** by Alvim by G1-030 VSWIR, -130 VSWIR, and -2050.

<sup>5</sup> Factory preset for DPC = Defect pixel correction

<sup>6</sup> Color models only

<sup>7</sup> For monochrome models: Y only

Figure 62: Image data flow of Alvim G1 cameras



### Feature descriptions and firmware downloads

Alvim Features Reference: [www.alliedvision.com/en/support/technical-documentation/alvim-gige-documentation](http://www.alliedvision.com/en/support/technical-documentation/alvim-gige-documentation)

Firmware downloads: [www.alliedvision.com/en/support/firmware-downloads](http://www.alliedvision.com/en/support/firmware-downloads).



# Firmware update



This chapter describes how firmware is updated on Alvium G1 cameras.

## Please note

You should update firmware only to change camera functions or fix known issues.

**Consider:** Any firmware update may not only add new features to a camera or fix known issues. It may also replace previous features or change camera characteristics. See firmware release notes for details.



### Keep the camera connected

- Keep the camera and the computer running while you are executing a firmware update.
- If the camera is powered down during firmware update, it may get into a non-functional state. Recovery may not be possible.



### Use only suitable firmware

If unsuitable firmware is used, the camera may get into a non-functional state.

- Only update to newer versions. Do not downgrade firmware to an older version, unless this has been explicitly communicated.
- We recommend updating the firmware to the next increment version only. Skipping versions may cause issues.

## Firmware update with Vimba X

1. Download and install **Vimba X**.  
The download includes Vimba X documentation.
2. Download the firmware (AVF file).



### Downloads

- For **Vimba X**, see [www.alliedvision.com/en/products/software/vimba-x-sdk](http://www.alliedvision.com/en/products/software/vimba-x-sdk).
- For firmware updates, see [www.alliedvision.com/en/support/firmware](http://www.alliedvision.com/en/support/firmware).

3. Connect your Alvim camera to the host.
4. Execute the installer of the firmware updater.  
The **Vimba X Firmware Updater** window opens, displaying your camera and the installed firmware version.
5. Continue with [Updating the firmware](#) on page 163.

## Updating the firmware



### Screenshots

The following instruction shows the firmware update on a **Linux** system. On **Linux** systems with other skins and on **Windows**, the GUI will look different.

The screenshots show an Alvium CSI-2 camera, but it applies to all interfaces.

1. Click **Open** to select the firmware for the update.

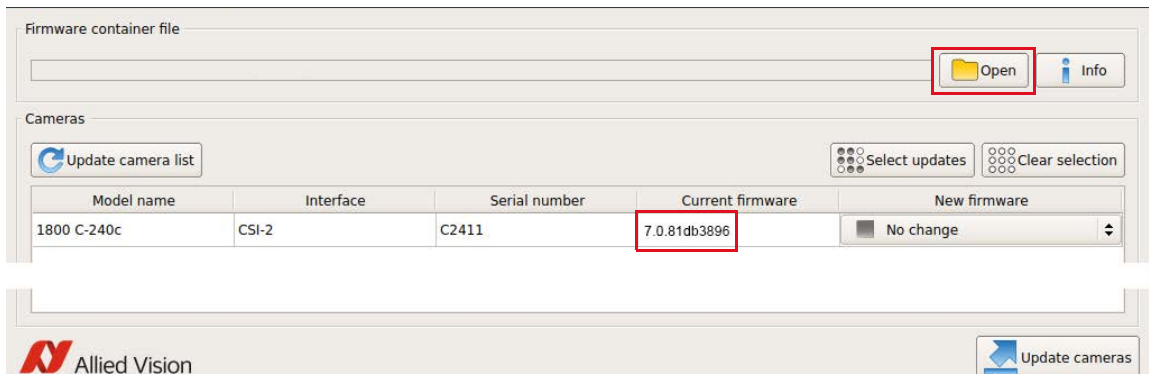

Figure 64: The camera and installed firmware are displayed

2. Select the firmware for the update from the drop-down menu.

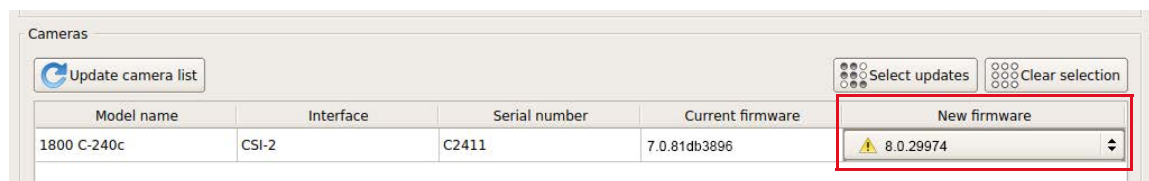

Figure 65: The firmware version is selected

3. Click **Update cameras**.



Figure 66: The update is being prepared

- Click **OK** to confirm.



Figure 67: The command to update the firmware is confirmed

The update progress is displayed.

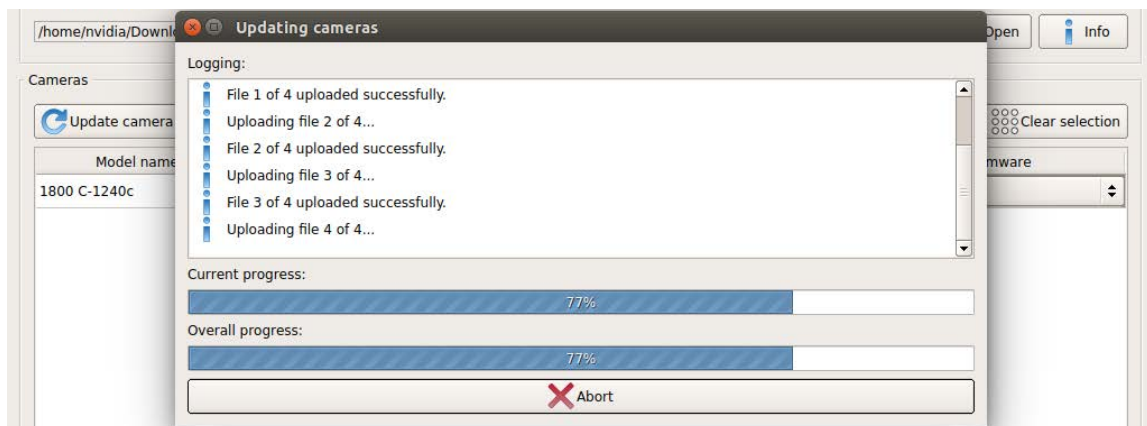

Figure 68: The update progress is displayed

- Click **Close** to confirm the completion of the update.

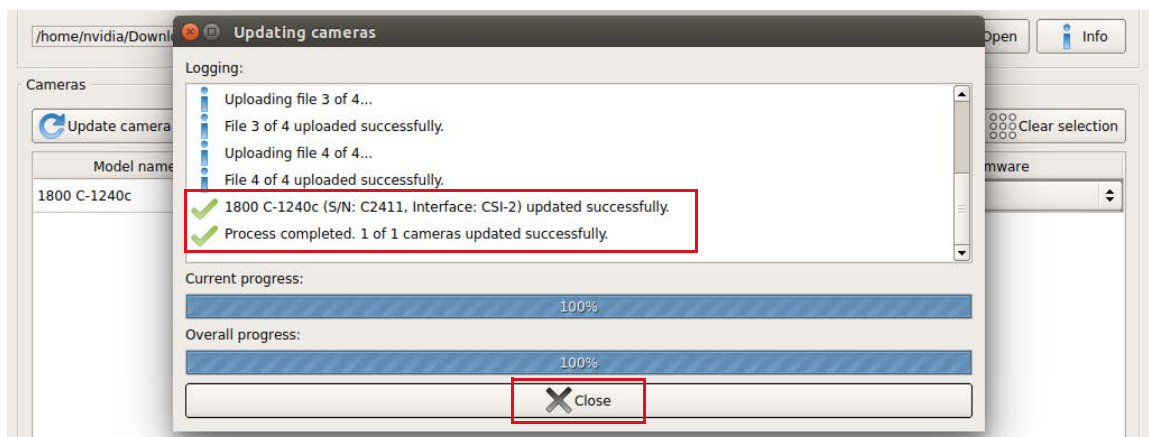

Figure 69: The update has been successfully completed

The camera is displayed with the updated firmware version.

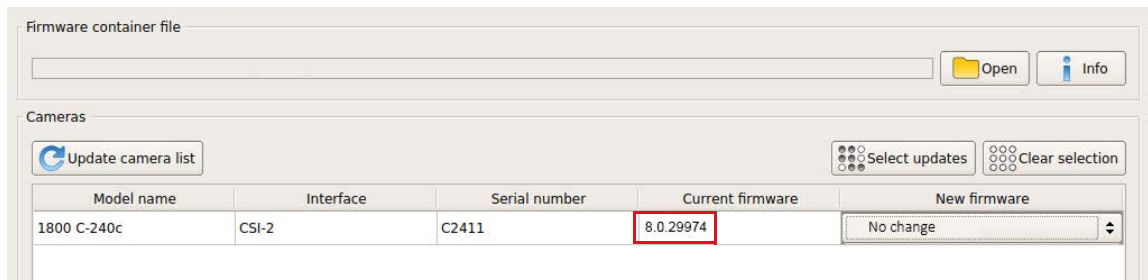

Figure 70: The updated firmware version is displayed

## Error handling

If firmware update fails,

- The camera is not recognized by **Vimba X Viewer**.
- You can repeat the firmware update.

Should the firmware update not succeed, please contact support at [www.alliedvision.com/en/about-us/contact-us/technical-support-repair-/-rma](http://www.alliedvision.com/en/about-us/contact-us/technical-support-repair-/-rma).

# Performance and troubleshooting



This chapter includes:

Tips and tricks to connect 1000BASE-T .....	167
Optimizing performance .....	174
Reference system .....	180
Troubleshooting common issues .....	182

# Tips and tricks to connect 1000BASE-T

This section is going to help you set up applications more easily.



## Data in this section

Data in this section was adapted from the corresponding section of the Alvim G5 User Guide. General information should be correct, but some values may not be suitable for Alvim G1.



## Troubleshooting

This section is covering most issues to enable proper camera operation. Should you need more help, see [Troubleshooting common issues](#) on page 182.

## Hardware selection

The selection of hardware components is a key factor to minimize the risk of dropped frames. This can be achieved by such as the recommended NICs to reduce the workload for the CPU or by real-time operating systems.

All components must support the link speed required to transfer and process the data output by the camera. Otherwise, the link speed of the camera must be configured accordingly. If a part of the link on the path is under heavy load, a QoS (quality of service) can be used to ensure the needed throughput.

## Intel I219LM chipset

Laptops, NICs, or Ethernet adapters using **Intel I219-LM** chipset may cause problems when Alvim G1 is connected directly. The link may not be activated or only runs at reduced bandwidth. The general functionality of the camera might also be limited. As a workaround, connect the camera to a different network adapter.



## Recommended products

Recommendations for products are based on tests and positive experience. We plan to extend these recommendations in future.

## SFP adapters

Inexpensive RJ45 / xBASE-T SFP+ modules can be used to integrate cameras in fast (Q)SFP+ or (Q)SFP28 equipment. Please check that SFP+ modules support 1000BASE-T.

## NIC hardware installation

Connect NICs directly to PCIe lanes of the CPU. If the NIC is connected to the chipset, ensure that the bandwidth between chipset and CPU is sufficient. Example: A NIC and an NVME SSD connected to the chipset, can create a bottleneck between chipset and CPU.

## NIC firmware and drivers

Consider updating the firmware of the NIC, if available. Use newest drivers available.

## NIC driver settings



### Switches

You must apply the same settings to switches as to NICs.



### 1000BASE-T mode

The 1000BASE-T mode must be enabled on some NICs and SFP modules.

In systems with more than one NUMA (non-uniform memory access) node, the interconnect between the nodes can become a bottleneck. We recommend you to optimize the settings as suggested by the CPU and NIC manufacturer. If possible, lock the host software to the NUMA node connected to the NIC.

## NIC driver settings under Linux



### Receive buffer size

You can increase the receive buffer size to handle the data throughput

- Temporarily: `sysctl -w net.core.rmem_max=33554432`
- Permanently: Add to the file `/etc/sysctl.conf`:  
`net.core.rmem_max=33554432`

The following commands can be used to find suitable settings. Note that these settings are **only temporary**. Adjust the corresponding system configuration files to change the settings permanently.

- Enabling Jumbo frames by setting the MTU size:  
`ifconfig <dev> mtu 9000`
- Setting the IP address:  
`ip a a 169.254.240.4/16 dev <dev>`



- Some 1000BASE-T NICs do not support auto negotiation.  
Setting the link speed manually:  
`ethtool -s <dev> autoneg off speed 1000`
- Enabling **Ethernet Flow Control**:  
`ethtool -A <dev> tx on rx on`  
`ethtool -A <dev> autoneg on`  
`ethtool -r <dev>`

## NIC driver settings under Windows

- Maximize the Jumbo frame size.
- Maximize the number of receive buffers.
- Switch off all non-required drivers, including filter drivers, in the network adapter settings. Mostly, the Vimba X filter driver helps to increase the performance. Be aware that using a PCAP filter, such as **Wireshark**, has an impact on the performance.
- Optimize settings related to IRQs (interrupt requests) in the network driver settings (interrupt moderation).
- RSS (receive side scaling) should be enabled to improve the performance when multiple cameras or several network adapters are connected to the host.
- Enable **Ethernet Flow Control** for Rx and Tx traffic.

## Operation system settings

### Settings under Linux

Be aware of automated network configuration tools. If configured incorrectly, these tools can periodically remove the network settings and try to find a connection to the Internet. Use a static configuration and deactivate these tools to avoid issues.

### Settings under Windows

- Disable any power-management that might impact the performance, especially on NICs, PCIe or the CPU.
  - Activate **Ultimate Performance** for power plan.
  - Disable sleep modes that turn off the screen.
- Avoid unnecessary CPU and network load, also on different network adapters where no camera is connected.
- Disable antivirus software if possible.
- Avoid system events causing lost packets, such as by plugging in USB devices.

## Vimba X TL settings

Configuring the **Vimba X** TL (transport layer) settings, can help to reduce dropped frames significantly. Look out for GenICam feature names starting with GVSP. Because every system is specific, individual experiments must be done.

This is an overview of GigE TL streaming features.



### Transport layer descriptions and firmware downloads

Alvium Features Reference: [www.alliedvision.com/en/support/technical-documentation/alvium-gige-documentation](http://www.alliedvision.com/en/support/technical-documentation/alvium-gige-documentation)

Firmware downloads: [www.alliedvision.com/en/support/firmware-downloads](http://www.alliedvision.com/en/support/firmware-downloads).

### GVSPDriverSelector

GVSPDriverSelector controls which software component is used to handle the streaming.

- **Windows:** Either the stream engine of the transport layer or the filter driver is used to receive and process the GVSP packets.
- **Linux:** Only the transport layer can be used.
- **Values:**
  - *Socket*: Use of the transport layers stream engine
  - *Filter*: Use of the filter drivers stream engine

Figure 71 gives an overview of the different stream handling methods.

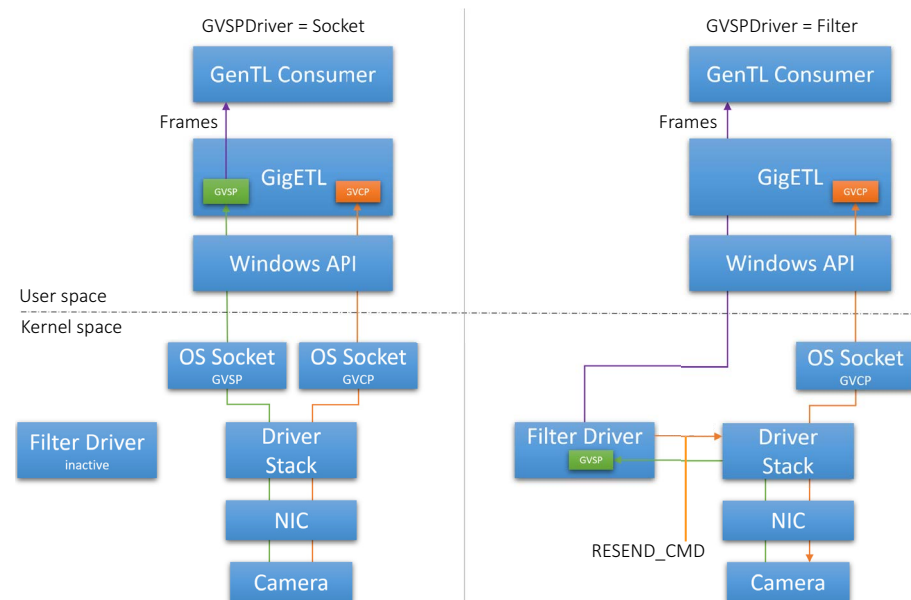

Figure 71: Stream handling with GVSPDriverSelector set to Socket or Filter

The filter driver minimizes the risk of lost frames substantially because it reduces the interactions between the user space and the kernel space, taking workload off the system:

When `GVSPDriver` is set to `Socket`, GVSP packets are processed in the user space. The downside of this approach: For each packet, system calls from the user space are required to enable GVSP packets pass from the kernel space.

Switching and transferring data between the kernel space and the user space is a time consuming process. This limits the number of GVSP packets a system can handle per second. Ensure the camera does not exceed this limit.

When `GVSPDriver` is set to `Filter`, the GVSP packets are processed by the filter driver that runs in the kernel space. This removes the linear dependency between system calls and GVSP packets. The filter driver copies the complete frame into the user space, coupling the number of system calls to the frame rate. Since the frame rate is substantially lower than the packet rate, the system has more resources left to handle the GVSP packets.

**We recommend using the filter driver instead of the socket driver to increase performance and reliability.**

If you cannot use the filter driver, you can reduce the number of GVSP packets per second. Increasing `GVSPPacketSize` is the only option to achieve this without reducing the performance of the camera.

## GVSPPacketSize

`GVSPPacketSize` configures the total size of a GVSP packet, including the IP-, UDP- and GVSP headers.

The performance of the stream processing is largely determined by the number of received packets. [Figure 72](#) shows how `GVSPPacketSize` affects the CPU load during streaming at different packet sizes for the socket driver and the filter driver.

The diagram shows the total CPU load over all cores; on single cores, the difference between socket and driver is much larger. Values on your system may vary from values measured on our test system, but the relation is the same.

The packet size is inversely proportional to the number of packets per second. [Figure 72](#) shows that increasing the packet size reduces the number of packets, minimizing the risk of lost frames.

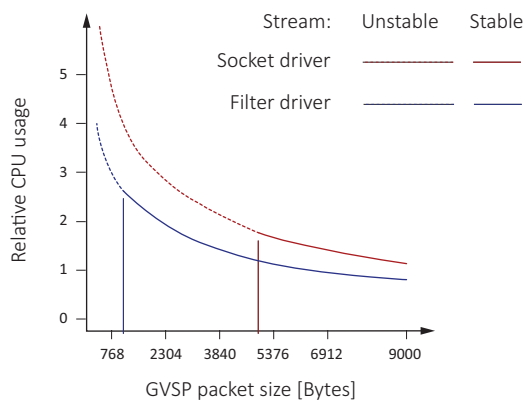

*Figure 72: GVSPPacketSize versus CPU usage while the camera is streaming*

**Note:** We recommend allowing the maximum packet size possible. To determine the maximum packet size supported by your system, the **Vimba X** API includes an automatic detection: Executing the **GVSPAdjustPacketSize** command first negotiates with the camera for the best possible packet size, then automatically sets **GVSPPacketSize**.

If the detected size is 1500 Bytes or less, ensure that Jumbo Frames are enabled on the host. Jumbo Frames must be enabled on all active Ethernet components.

## GVSPBurstSize

**GVSPBurstSize** configures the number of GVSP packets that are processed at once before further checks, like missing packet detection, are executed.

**Note:** Currently the stream performance is not significantly affected. We recommend using the default value of **1**.

## GVSPHostReceiveBufferSize

**GVSPHostReceiveBufferSize** controls the socket buffer space used to receive GVSP packets. The operating system adjusts the socket buffer continuously. The value may be limited internally by the operating system. See the **SO\_RCVBUF** documentation of the operating system.

**Note:** This feature cannot be used with the filter driver.

## GVSPTimeout

**GVSPTimeout** is used to react on a possible streaming interruption. If no GVSP packet is received during the last **GVSPTimeout** milliseconds, the stream engine forces a resend of currently missing GVSP packets.



### Dropped frames with certain ROIs

With certain ROIs, dropped frames may occur. This can mostly be avoided when **GVSPTimeout** is set to  $1/\text{frame rate}$ .

## GVSPtiltingSize

**GVSPtiltingSize** is used to cancel the reception of a single frame if a certain number of GVSP packets of the following frame has already been received.

The frame is marked as incomplete and returned to the GenTL consumer.

## GVSPMaxRequests

**GVSPMaxRequests** is used to configure the maximum amount of **RESEND\_COMMANDS** requested for a missing GVSP packet. Setting the feature to **0** disables the GigE Vision resend mechanism. The transport layer or filter driver does not request the re-transmission of any missing GVSP packet.

## GVSPMissingSize

`GVSPMissingSize` is used to cancel the reception of a single frame if the resend limit `GVSPMaxRequests` is reached for too many packets.

The frame is marked as incomplete and returned to the GenTL consumer.

## Configuring the resend behavior

`GVSPMaxLookBack` and `GVSPMaxWaitSize` can be used to configure the "timing" of `RESEND_CMDs`.

### GVSPMaxLookBack

`GVSPMaxLookBack` can be used to delay the first `RESEND_CMD` for a missing GVSP packet by X packets.

### GVSPMaxWaitSize

`GVSPMaxWaitSize` can be used to delay the `RESEND_CMD` for the same missing GVSP packet. The transport layer or the filter driver waits until `GVSPMaxWaitSize` of packets has been reached before requesting a resend for the same packet again.



*GVSPMaxLookBack = 1 | GVSPMaxWaitSize = 2 | GVSPMaxRequests = 2*

*Figure 73: Controlling the resend of packets (example)*

# Optimizing performance

## Image transfer with rolling shutter cameras

Alvium G1-500m/c, G1-1240, and G1-2050m/c

If acquisition is started and stopped in a short sequence, no image is transferred to the host. The duration cannot be predicted, because it depends on various factors.

## Frame rate jitter

Alvium G1-500m/c, G1-1240, and G1-2050m/c

Generally, some parameters can be changed during exposure without affecting the timing. For models with ON Semiconductor AR sensors and rolling shutter sensors, a different behavior must be considered for **camera operation in freerun mode without triggering**:

Changing parameters during exposure leads to frame rate jitter. When parameters are entered, the next frame starts only after readout and sensor reconfiguration delay are finished. When the camera is run in **ExposureAuto** mode, the actual frame rate is less than the calculated value for the corresponding exposure time. Consider frame rate jitter for your application, including a gap between **ExposureActive** signals.

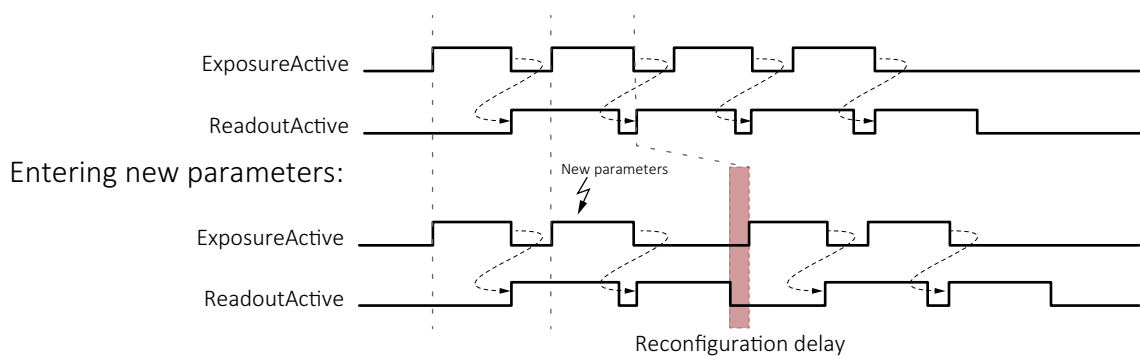

Figure 74: Delayed exposure due to parameter changes



### Parameter changes in triggered mode

See [Ignored triggers](#) on page 158 for more information.

## Value changes by feature interdependencies

The conversion between time and clock cycles affects control values. Features for pixel format, bandwidth, ROI, exposure time, and triggering are related to each other. Changing values for one feature can change values for another feature. For example, frame rates can be reduced when `PixelFormat` is changed subsequently. [Figure 75](#) shows the interdependencies.

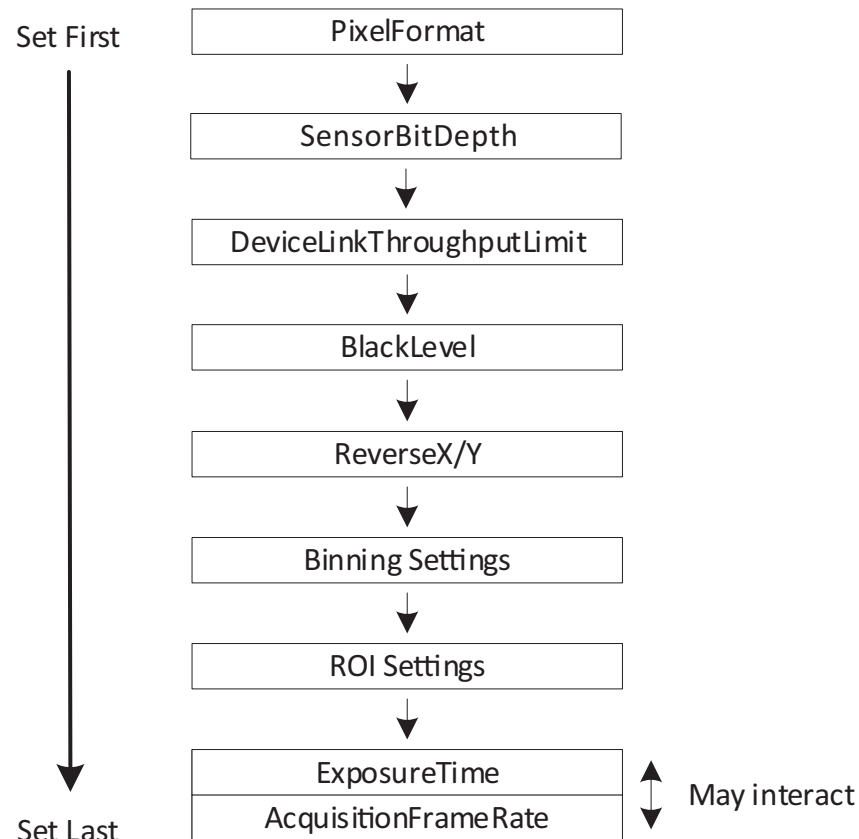

*Figure 75: Interdependencies between features*

### Effects for the interdependent features

Changing one control's value affects other control's values, such as:

If: `Height` value is changed.

Then: Other values may be affected, such as for `AcquisitionFrameRate` and `ExposureTime`.

We recommend you to consider:

- The more features you adjust, the more current values deviate from previously set values.
- The same effects that apply to `ExposureTime`, also apply to `AutoExposure`.
- To avoid readjustments, apply settings in the order shown in [Figure 75](#).

## Impact by other features

Input	Output	
	Exposure time values	Frame rate
AcquisitionFrameRate	Not affected	Affected
ExposureTime	Affected as expected	Affected
DeviceLinkThroughputLimit	Affected	Affected
Height	Not affected	Affected
Width	May be affected	May be affected

Table 96: Impact by other features

## Exposure times and frame rates with Sony IMX rolling shutter cameras

Alvium G1-1240m/c, G1-2050m/c

Generally, long exposure times result in low frame rates because one is roughly the inverse of the other. For Alvium G1 cameras with Sony IMX RS sensors:

- The range of available frame rates depends on the exposure time.
- The exposure time must be increased when low frame rates are used.
- The available range for frame rate values depends on the exposure time. If by changing the exposure time, the previous frame rate is moved out of the available range, the frame rate is adjusted automatically.



## Dark current compensation

All sensors accumulate dark current in the pixels. Dark current increases the signal level and black level. Most sensors in Alvium G1 cameras compensate for this.

If cameras are operated at high temperatures or long exposure times, compensation reaches its limits. The typical compensation mechanism uses a **margin** to compensate for dark current. This works only until dark current reaches the size of the margin. The following table shows the relation of the margin and accumulated dark current for a pixel in 8-bit mode with a maximum value of 255.

Effective signal versus noise	Description
	The pixel has accumulated no dark current, the margin has maximum size.
	The pixel has accumulated some dark current, reducing the size of the margin.
The following images show a pixel that has accumulated a higher dark current than the margin.	
	The pixel has accumulated dark current, the margin reduces to 0. <ul style="list-style-type: none"> <li>• Dark current compensation stays active.</li> <li>• Maximum saturation signal decreases.</li> <li>• Fixed pattern noise increases.</li> </ul> This sensor-internal compensation is typically used in the analog domain.

Table 97: Accumulated dark current affecting the effective image signal

## Additional compensation

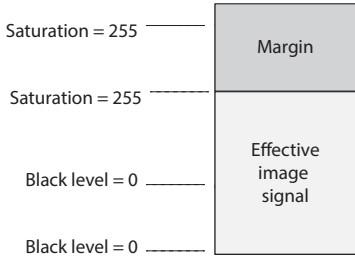
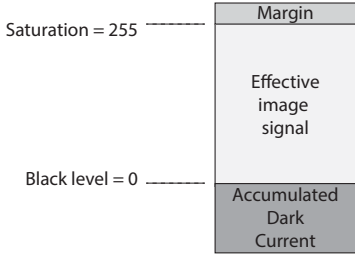
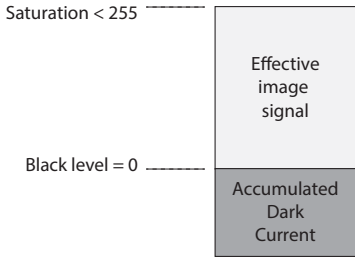

If compensation limits are reached and you cannot decrease operating temperature or exposure time, what can you do to keep signal quality high?

You can increase the margin size by using gain, with the following side effects:

- To give space to a larger margin, the effective pixel capacity decreases.
- White and light gray values are shifted down to gray.

## Shutter types affecting image readout

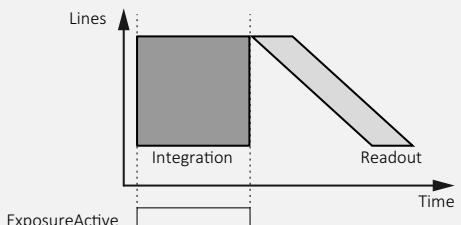
Some Alvium G1 camera models are operated using global shutter (GS):

Property	Line readout	Moving image
Global shutter (GS)		

Other models use rolling shutter (RS). Alvium G1-2050 models with Sony IMX183 sensor offer global reset shutter (GRS) in addition:



Property	Rolling shutter (RS)	Global reset shutter (GRS)
Line readout		
Line exposure start	Deferred from line to line	Common for all lines
Line exposure time	Common for all lines	Increases from line to line
Image acquisition of moving objects		
Image brightness	Constant over the image	Varying over the image
Moving objects	Distorted shape	Shape without distortion
Typical application	Static objects	Moving objects
Compensation	Use an additional mechanical shutter or use a strobe light:	
		

Table 98: Shutter types affecting image readout

## Operating systems and bandwidth

If the camera data output exceeds the bandwidth supported by the host computer, images may be corrupted. This section gives some background information to enable proper image transfer.

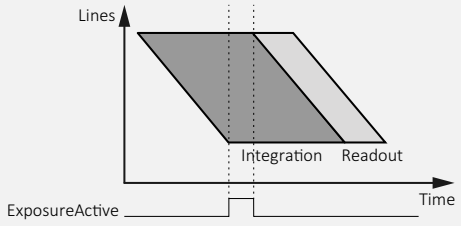
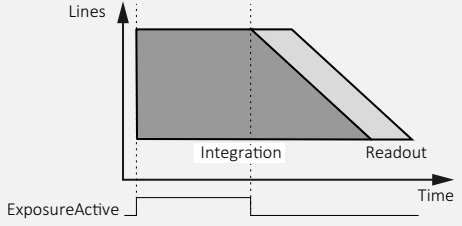
### Sensor data output and camera data output

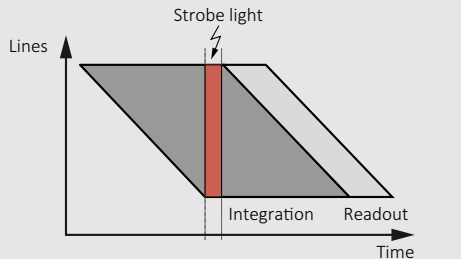
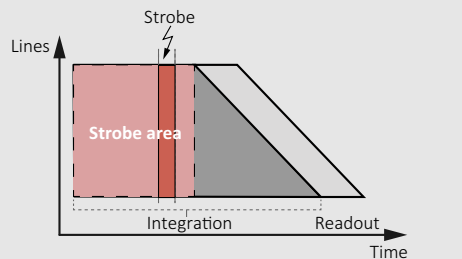
Typically, the required bandwidth for image acquisition can be estimated for a given frame rate, pixel format, and resolution by over-the-thumb calculations.

Figure 76 shows the bandwidth for a higher (1) and a lower (2) value for `DeviceLinkThroughputLimit` with Alvim G1.

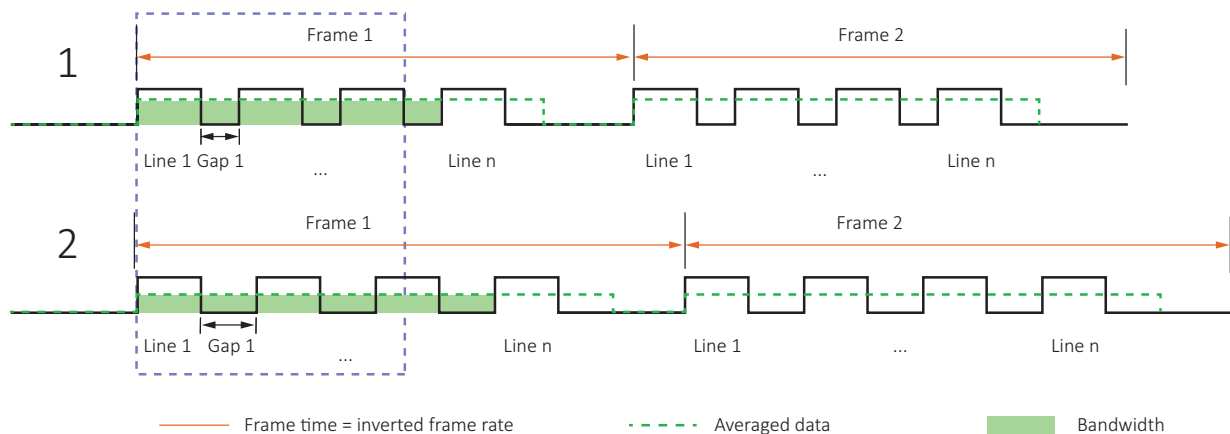

Figure 76: Sensor data output and camera data output

- Generally, data rate is averaged over the frame time.
- When high-resolution Alvim G1 cameras are operated at higher frame rates, corrupted frames can occur. This is shown schematically in Figure 76.
- Using `DeviceLinkThroughputLimit`: Reduces the maximum line data rate.

`DeviceLinkThroughputLimit` controls the maximum bandwidth of the data streamed out by the camera. When the value for this feature is reduced, the gaps between the lines are increased. This reduces the frame rate and therefore the bandwidth.

Additionally, you may reduce the frame rate to reduce bandwidth.

Consider that **Vimba X Viewer** does not gray out values that exceed the bandwidth supported by the host computer.



#### Feature description for `DeviceLinkThroughputLimit`

For a description of this feature, see the Alvim Features Reference: [www.alliedvision.com/en/support/technical-documentation/alvim-gige-documentation](http://www.alliedvision.com/en/support/technical-documentation/alvim-gige-documentation).

## Hardware and bandwidth

For a smooth data transfer of Alvium G1 cameras, the host computer must be equipped with a high-bandwidth 1000BASE-T compliant NIC. We recommend using direct point-to-point links from camera to NIC for best performance.

## Vimba X settings

During freerun, Alvium G1 cameras do not automatically adapt the frame rate to the limits of your system, including the NIC. If the data rate is too high, it receives corrupted frames. The image transfer status in **Vimba X Viewer** is signaled as **Running**. However, the corrupted frames are not displayed. For a solution, see [Camera cannot acquire images](#) on page 183.

## Reference system

We have tested available frame rates on a desktop PC. Cameras were operated in `AquisitionMode = Continuous`, frame rates were measured using **Raspberry Pi** and **pigpio library**.



### More information on pigpio library

For more information on pigpio library, see <https://abyz.me.uk/rpi/pigpio/index.html>.

Stated values were measured for bandwidths of 122 MByte/s and 12 MByte/s for [Operation for maximum frame rates](#), using the following test setup:

Component	Property
Operating system	Windows 10 Pro Version 1903, Build 18362. 1256
Work station	Dell Precision T5610
System type	x64-based PC
CPU	Intel(R) Xeon(R) CPU E5-2620 v2 @ 2.10GHz, 2095 Mhz, 6 Cores, 12 logical processors
BIOS	Dell Inc. A07, 4/29/2014
SM BIOS Version	V2.7
RAM	16 GB DDR3 DIMM (2 x 8 GB), 1600 MHz
Total virtual memory	18.3 GB
Page file space	2.38 GB
Kernel DMA Protection	Off
Virtualization-based security	Not enabled

Table 99: Test setup components (sheet 1 of 2)

Component	Property
Hype-V enabled for	<ul style="list-style-type: none"> <li>VM Monitor Mode Extensions</li> <li>Second Level Address Translation Extensions</li> <li>Virtualization Enabled in Firmware</li> <li>Data Execution Protection</li> </ul>
Graphics controller	NVIDIA NVS 310, driver 10.18.13.5362, 512 MB DDR3 PCI-Express
Hard discs 1,2 (RAID 1 system)	Seagate Desktop HDD S-ATA 7200 rpm, 1 TB, firmware CC45
NIC	Marvel FastLinQ Edge 10Gbit Network Adapter
NIC firmware	V3.0.18.0
Ethernet driver	Marvel Semiconductor Inc. 3.0.18.0

Table 99: Test setup components (sheet 2 of 2)

## Feature values

Source	Feature	Value	Comments
Camera	DeviceLinkThroughputLimitMode	<i>On</i>	Not applicable
	DeviceLinkThroughputLimit	115MByte/s <sup>1</sup>	1000BASE-T NICs
Transport layer	GVSPDriverSelector	<i>Filter</i>	Windows only
	GVSPPacketSize	16334	Vimba X default
	GVSPBurstSize	1	
	GVSPHostReceiveBufferSize	Not applicable	See footnote <sup>2</sup>
	GVSPMaxLookBack	30	Vimba X default
	GVSPMaxWaitSize	100	
	GVSPMissingSize	256	
	GVSPTiltingSize	100	
	GVSPTimeout	70	

<sup>1</sup> This value enables the host to request resent packets and sent command packets.

<sup>2</sup> This feature is disabled when *GVSPDriverSelector* is set to *Filter*.

Table 100: Feature values



### Description for camera and transport layer features

See the Alvim Features Reference: [www.alliedvision.com/en/support/technical-documentation/alvim-gige-documentation](http://www.alliedvision.com/en/support/technical-documentation/alvim-gige-documentation).

# Troubleshooting common issues

## Camera is not powered

### Camera or system issue?

When the camera is connected, the [Status LEDs](#) signal the camera status. If the LEDs of a connected camera are not illuminated, check with a working camera.

### Power supply

If using a custom power supply, ensure that

- The adapter and wire gauge are rated 1 A at 12 VDC (lower current for higher voltages).
- The TFM connector is supplied with minimum 10.8 VDC despite voltage drop across the cabling.

## Camera is not detected in the viewer

The camera is powered correctly, but it is not detected in the viewer.

### Ethernet cabling

Damaged or poor quality Ethernet cabling can result in no cameras found, dropped packets, decreased bandwidth, and other problems. Use Category 6 or higher rated Ethernet cabling.

### NICs and NIC ports

Laptops, NICs, or Ethernet adapters using **Intel I219-LM** chipset may cause problems when Alvium G1 is connected directly. The link may not be activated or only runs at reduced bandwidth. The general functionality of the camera might also be limited. As a workaround, connect the camera to a different network adapter.

### Ethernet adapter settings

Return to [Modifying the NIC IP address](#) on page 141, which describes how to adjust the IP address of the host adapter. Do not use gateways on your NIC. Connect a single camera directly to your NIC.

Ensure that IP address of the adapter is on the same subnet as the camera. If not, return the adapter address to the Auto IP configuration. A sample IP configuration for the camera and adapter is shown below.

	Adapter	Camera
IP address	169.254.23.2	169.254.43.3
Subnet mask	255.255.0.0	255.255.0.0

Table 101: Sample IP configuration

## Camera cannot acquire images

The camera is detected in the viewer but does not acquire images.

Revert the camera settings to factory default: In the controller window of **Vimba X Viewer**, under `SavedUserSets`, set `UserSetDefaultSelector = Default`, click `UserSetLoad`, and click the `Execute` button.

### If StatFramesDelivered / StatPacketsReceived = 0

- Click on `Stream > Statistics` to view camera freerun statistics.
- Disable your firewall on Ethernet adapter connected to camera to avoid blocking incoming traffic.
- Ensure that in **Vimba X Viewer**:  
`AcquisitionFrameRateEnable = True`  
`TriggerSelector = FrameStart`  
`TriggerSource = Software` or `LineX`
- Consider that some trigger modes require a trigger event to capture frames.

### If StatFramesDropped ≠ 0

Packets are incoming, but all dropping.

Enable Jumbo Frames on your adapter, see [Adjusting the NIC driver settings](#) on page 142.

### If StatFramesDelivered value increases, but images are black

- Ensure your scene is sufficiently lit.
- Increase the exposure time value, using `ExposureTimeAbs`.
- Ensure the lens is properly installed and the lens cap has been removed.



If you are still having problems, please contact support at [www.alliedvision.com/en/about-us/contact-us/technical-support-repair-/-rma](http://www.alliedvision.com/en/about-us/contact-us/technical-support-repair-/-rma).

## Packets are dropped

- Check the Ethernet cable. A damaged cable often causes the link to negotiate a lower speed as fallback.
- **Windows:** Disable auto updates and telemetry.
- Use the latest NIC driver from the NIC manufacturer.
- Enable Jumbo Frames/Packets on the NIC. Larger packets result in less overhead on the host CPU. See [Enabling Jumbo Packets](#) on page 142.



### Available packet size

Be aware that the effective maximum packet size is limited to the biggest size supported by all network devices on the path.

- Enable Ethernet Flow Control on NICs and switches, see [NIC driver settings](#) on page 168.
- Disable the firewall if no filter driver is used.
- If possible, use a dedicated network infrastructure:
  - Ideally, each camera has a point-to-point connection to a dedicated network adapter in the host.
  - Separate camera networks from other networks.
  - Avoid aggregating multiple cameras over a single network link if possible. The more cameras use a common link, the lower becomes the usable total system throughput, caused by packet losses or less effective processing on the host side.
- **Linux only:** Run as root, allowing the OS to boost the priority of the Allied Vision driver thread, and the driver to bind directly to the NIC adapter. Users who feel running as root compromises their system security may find the following implementation satisfactory:
  - Set the executable owner as root.
  - Set the “setuid” permission bit on the executable.
  - In code, when application starts use `capset()` to release all but these privileges: `CAP_SYS_NICE`, `CAP_NET_ADMIN`, `CAP_NET_BROADCAST`, `CAP_NET_RAW`. The application will start with all root privileges, but it will drop them immediately after startup.



# Index

## A

AcquisitionActive .....	156
Auto IP configuration .....	183

## B

back panel .....	147
------------------	-----

## C

camera connectors .....	147
camera hardware .....	145
camera mounting .....	134
Category 6 .....	143, 182
connectors .....	145
copyright .....	34
current and voltage .....	37

## D

dark current compensation .....	177
digital binning .....	49
dimensions .....	110
document	
conventions .....	28
history .....	24
overview .....	15

## E

ESD .....	36
-----------	----

## F

FCC .....	32
feature availability .....	118
firmware update .....	161
Flow Control	
Linux .....	169
Windows .....	169
frame rates > reference settings .....	46

## G

general safety notes .....	34
GenICam .....	42
GigE Vision .....	42
global reset shutter (GRS) .....	178
global shutter (GS) .....	178

## H

heat dissipation .....	35
heat sink mounting .....	133

## host computer

configuring .....	140
connecting .....	143
connecting 1000BASE-T .....	167
Jumbo Packets .....	142
NIC driver installation .....	140
NIC driver settings .....	142
NIC IP address .....	141

## I

I/Os, GPIOs	
connector pin assignment .....	148
description .....	149
image data flow .....	159
interfaces .....	145
IP class .....	42
IR cut filter .....	114

## J

Jumbo Packets .....	142
---------------------	-----

## L

lens	
focal length vs. FOV .....	120
maximum protrusion .....	40, 113
mounting .....	136
mounts .....	113
vignetting .....	121

## M

mass .....	110
MutipleRegions .....	49

## N

NIC	
safety .....	38
troubleshooting .....	182

## O

operating temperature .....	50
-----------------------------	----

## P

power consumption > reference settings .....	50
powering up the camera .....	144

## R

readout modes .....	47
reference system .....	180
ROI frame rates .....	46
rolling shutter (RS) .....	178

**S**

safety .....	2, 4, 8, 14, 29, 35
camera power .....	37
electrical connections .....	36
heat dissipation .....	35
heavy lenses .....	36
lens mounts .....	35
lens protrusion .....	40
mounting cameras .....	36
NIC .....	38
optical components .....	39
sensor .....	39
sensor ADC readout modes .....	47
sensor binning .....	49
sensor position accuracy .....	115
sensor shutter types .....	48
shock and vibration .....	42
specifications .....	41
standards applied .....	42
status LEDs .....	154

**T**

technical drawings .....	110
torque values .....	134
trigger latency .....	156
trigger signal flow .....	156
triggering with RS cameras .....	157
troubleshooting .....	166
bandwidth .....	179
dark current compensation .....	177
dropped packets .....	184
feature interdependencies .....	175
frame rate jitter .....	174
troubleshooting common issues .....	182

**U**

UART .....	149
user sets .....	117

**V**

vignetting .....	121
------------------	-----

**W**

white balance default .....	109
-----------------------------	-----