



Manual EXO series

**exo174*, exo183*CL, exo249*CL, exo250*CL, exo252*CL,
exo267*CL, exo304*CL, exo4000*CL, exo5000*CL**

Company Information

SVS-VISTEK GMBH
Mühlbachstr. 20
82229 Seefeld
Germany

Tel.: +49 (0) 81 52 9985-0
Fax: +49 (0) 81 52 9985-79
Mail: info@svs-vistek.com
Web: <http://www.svs-vistek.com>

This Operation Manual is based on the following standards:
DIN EN 62079, DIN EN ISO 12100, ISO Guide 37, DIN ISO 3864-2,
DIN ISO 3864-4, DIN ISO 16016:2002-5

This Operation Manual contains important instructions for safe and efficient handling of SVCam Cameras (hereinafter referred to as „camera“). This Operating Manual is part of the camera and must be kept accessible in the immediate vicinity of the camera for any person working on or with this camera.

Read carefully and make sure you understand this Operation Manual prior to starting any work with this camera. The basic prerequisite for safe work is compliant with all specified safety and handling instructions.

Accident prevention guidelines and general safety regulations should be applied.

Illustrations in this Operation Manual are provided for basic understanding and can vary from the actual model of this camera. No claims can be derived from the illustrations in this Operation Manual.

The camera in your possession has been produced with great care and has been thoroughly tested. Nonetheless, in case of any complaint, please contact your local SVS-VISTEK distributor. You will find a list of distributors in your area on www.svs-vistek.com

COPYRIGHT PROTECTION STATEMENT

Forwarding and duplicating of this document, as well as using or revealing its contents are prohibited without written approval. All rights reserved with regard to patent claims or submission of design or utility patent.

Content

1	Legal Information	6
2	Getting Started	7
2.1	Contents of Camera Set.....	7
2.2	Connect the camera.....	7
2.3	Camera status LED codes.....	7
2.4	Software.....	8
2.4.1	SVCapture 2.....	8
2.4.2	Camera Link Viewer Software.....	9
2.4.3	Update firmware.....	10
3	Connectors	11
3.1	Camera Link™	11
3.1.1	Connectors Camera Link™.....	11
3.1.2	Camera Link Pinout	12
3.2	Input / output connectors	14
4	The EXO	15
5	Feature description	17
5.1	Basics	17
5.1.1	Global shutter	17
5.1.2	Rolling Shutter	17
5.1.3	Exposure	20
5.1.4	Exposure speed	20
5.1.5	Acquisition and Processing Time	20
5.1.6	Auto exposure	21
5.1.7	Bit-Depth	21
5.1.8	Color.....	22
5.1.9	Resolution	23
5.1.10	Offset	23
5.1.11	Gain.....	24
5.1.12	Flip Image.....	25
5.1.13	Binning	26
5.1.14	Decimation	28
5.2	Camera Features	29
5.2.1	Basic Capture Modes	29
5.2.2	System Clock Frequency	32
5.2.3	Temperature Sensor	32
5.2.4	Camera Link timings	33
5.2.5	LookUp Table.....	35
5.2.6	ROI / AOI.....	36
5.2.7	Pixel Clock Frequency Selection	38
5.2.8	IR / glass filter	38
5.3	I/O Features	40
5.3.1	GenICam.....	40

5.3.2	PWM	41
5.3.3	Driver Circuit Schematics.....	43
5.3.4	Assigning I/O Lines – IOMUX	44
5.3.5	LED Strobe Control	48
5.3.6	Sequencer.....	50
5.3.7	Optical Input.....	55
5.3.8	PLC/Logical Operation on Inputs	56
5.3.9	Serial data interfaces.....	57
5.3.10	Trigger-Edge Sensitivity.....	58
5.3.11	Debouncing Trigger Signals.....	58
5.3.12	Prescale	60
6	Specifications	61
6.1	exo174*CL.....	62
6.2	exo183*CL.....	65
6.3	exo249*CL.....	68
6.4	exo250*CL.....	71
6.5	exo252*CL.....	74
6.6	exo267*CL.....	77
6.7	exo304*CL.....	80
7	Dimensions	83
7.1	exo174*CL, exo249*CL, exo183*CL	83
7.2	exo250*CL, exo252*CL.....	87
7.3	exo267*CL, exo304*CL.....	90
7.4	exo4000*CL.....	93
7.5	exo5000*CL.....	97
7.6	C & CS mount.....	100
8	Terms of warranty	102
9	FAQ.....	103
10	Glossary of Terms	104

1 Legal Information

Information given within the manual accurate as to: March 8, 2019, errors and omissions excepted.

These products are designed for industrial applications only. Cameras from SVS-Vistek are not designed for life support systems where malfunction of the products might result in any risk of personal harm or injury. Customers, integrators and end users of SVS-Vistek products might sell these products and agree to do so at their own risk, as SVS-Vistek will not take any liability for any damage from improper use or sale.



Europe

This camera is CE tested, rules of EN 55022:2010+AC2011 and EN61000-6-2:2005 apply.

The product is in compliance with the requirements of the following European directives:

2014/30/EU	Electromagnetic compatibility (EMC)
2011/65/EU	Restriction of the use of certain hazardous substances in electrical and electronic equipment (RoHS)

All SVS-VISTEK cameras comply with the recommendation of the European Union concerning RoHS Rules



USA and Canada

This device complies with part 15 of the FCC Rules. Operation is subject to the following conditions: (1) This device may not cause harmful interference, and (2) this device must accept any interference received, including interference that may cause undesired operation.

This equipment is compliant with Class A of CISPR 32. Warning: In a residential environment this equipment may cause radio interference. This equipment has been tested and found to comply with the limits for a Class A digital device, pursuant to part 15 of the FCC Rules.

It is necessary to use a shielded power supply cable. You can then use the "shield contact" on the connector which has GND contact to the camera housing. This is essential for any use. If not done and camera is destroyed due to Radio Magnetic Interference (RMI) WARRANTY is void.

- > US/UK and European power line adapter can be delivered. Otherwise use filtered and stabilized DC power supply
- > Shock & Vibration Resistance is tested: For detailed Specifications refer to Specification

2 Getting Started

2.1 Contents of Camera Set

- > Camera
- > Power supply (if ordered/option)
- > Quick guide
- > User Manual
- > Software installer – SVCam Kit
- > Euresys camera file (optional)

2.2 Connect the camera

Before connecting your camera to power, make sure your data cable is connected properly. Always connect data cable before power.



CAUTION! – This camera does not support hotplugging

1. First, connect the data cable.
2. Then connect power supply.

Connect the power supply with the Hirose connector. When using your own power supply (voltage range 10 -25 V DC) see also [Hirose 12-](#) pin layout of the power connector. For power input specifications refer to [specifications](#).

2.3 Camera status LED codes

On power up, the camera will indicate its current status with a flashing LED on its back. The LED will change color and rhythm.

The meaning of the blinking LED status codes translates as follows:

LED status code	Indication
	system booting
	system ready
	system error

2.4 Software

Further information, documentations, release notes, latest software and application manuals can be downloaded in the download area on SVS-Vistek's [download area](#). Depending on the type of camera you bought, several software packages apply.

2.4.1 SVCapture 2

SVCapture 2.x is a XML based software tool. It provides the possibility to control a GenICam based camera. The image result of any modification of a camera's adjustment is immediately visible, making it the ideal tool to optimize camera adjustments.

SVCapture covers following interfaces:

- > GigE Vision
- > 10 GigE Vision
- > Camera Link
- > USB3

SVCapture is included in the SVCam Kit, you can download it for free from SVS-Vistek's [download area](#).

Please refer to the SVCam Kit Install guide for details. You will find this document in the download area as well.

Generally, any GenICam based software package should be able to run a SVS-Vistek camera (GigE Vision, USB3, Camera Link).



It is strongly recommended to uninstall the existing version of SVCam Kit or SVCapture before installing the new version. While installing, please deactivate your firewall and antivirus programs.

Quick guide install

- > Download the SVCam Kit matching to your operating system
- > Disable firewall and antivirus programs
- > Unpack and install the software and the drivers required for your camera's interface type
- > Enable firewall and antivirus programs

Connect your camera's interface cable and power. Start SVCapture. Select your interface type in the discovery dialogue, SVCapture should show your camera after about 30 seconds.

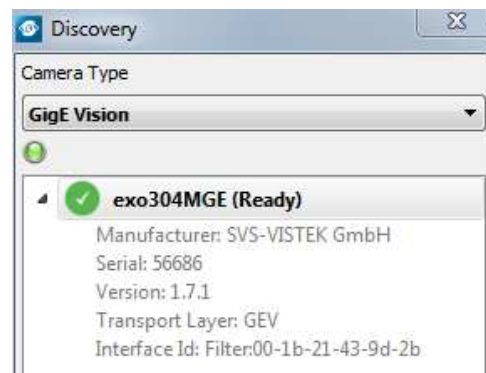

2.4.2 Camera Link Viewer Software

SVCam Kit or ConvCam are the recommended tools for modifying GenICam attributes. For viewing the resulting image you need external software. In most cases this will be the software delivered with your frame grabber. Assuming an Euresys framegrabber as an example, these are the steps for MultiCam Studio to display a camera image.

Run Multicam Studio.

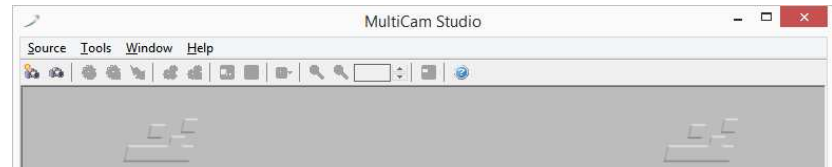

- > Add a new "source" to the application
- > Choose "Camera Link industrial Camera..."
- > Click "next"
- > In the list of camera vendors choose "SVS-VISTEK" and the camera you want to view.
- > Select frame grabber and connector

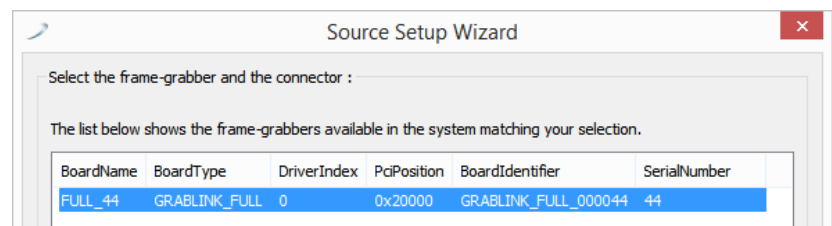

- > For "Topology" values refer to the Euresys documentation. At first: stay with "Mono" for topology

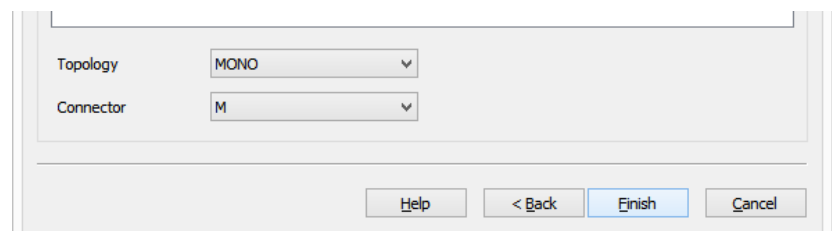

- > Choose your connector configuration
- > click "Finish"

According to your GenICam configuration, you should see the camera's image displayed.

For further information on Euresys Multicam Studio refer to the Euresys documentation.

2.4.3 Update firmware

Some features may not have been implemented in your camera at the time of selling. For updating your camera firmware to the most recent version, you need to download the firmware upgrade tool “CL FirmwareUpdater” and the firmware file (download it from website, login area) matching your camera model.

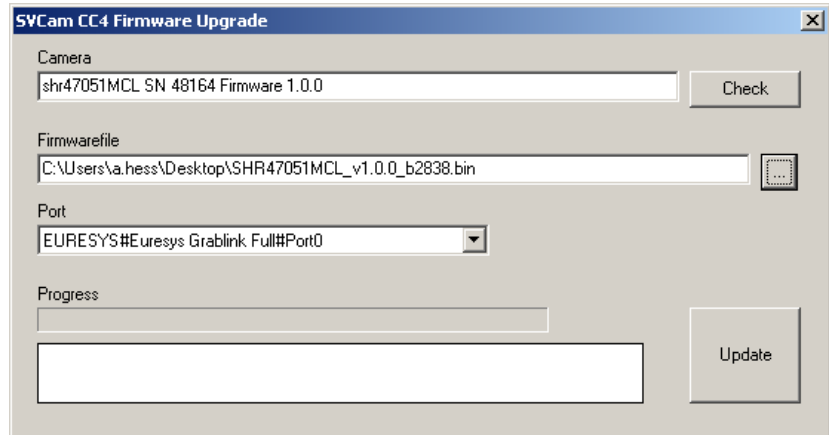

Execute firmware update

- > Unpack upgrade tool and the correct firmware file into any folder, e.g. “C:\temp”
- > Ensure proper camera connection configuration
- > Run the update tool
- > Adjust the port to the Camera Link port where your camera is attached
- > Press “check” button. Your camera and its current firmware should show up
- > Load the new firmware file
- > Press “update”. Wait until the process has finished. Do not touch the system while doing the upgrade!

3 Connectors

3.1 Camera Link™

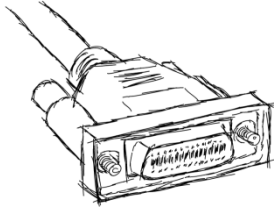

To use Camera Link a frame grabber is needed. Matching frame grabbers can be purchased from your distributor or from SVS-VISTEK.

3.1.1 Connectors Camera Link™



Specification	
Type	26 Pin connector MDR female
Mating Connector	3M
Part-Nr. connector	10126-6000EL
Part-Nr. hood	10326-A200-00
Operating Mode	Camera Link™ with RS 232 communication

3.1.2 Camera Link Pinout

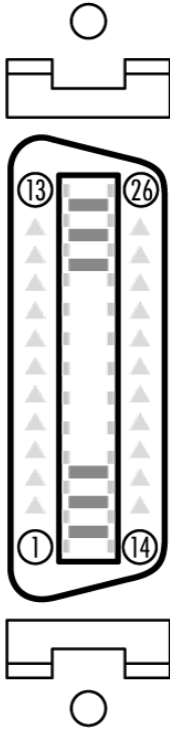

Pinout Pin	Signal Name	Direction	Signal Description
- 1 -	GND / 12 V	-	Shield 1 / 12 V power*
- 2 -	X0-	Camera to FG	Data
- 3 -	X1-	Camera to FG	Data
- 4 -	X2-	Camera to FG	Data
- 5 -	Xclk-	Camera to FG	Transmitter Clock / PVAL
- 6 -	X3-	Camera to FG	Data
- 7 -	SerTC+	FG to Camera	Camera Control (RS232)
- 8 -	SerTFG-	Camera to FG	Camera Control (RS232)
- 9 -	CC1-	FG to Camera	ExSync
- 10 -	CC2+	FG to Camera	Prin (not used)
- 11 -	CC3-	FG to Camera	External Camera Clock
- 12 -	CC4+	FG to Camera	nc
- 13 -	GND	-	Shield 3 / power return*
- 14 -	GND	-	Shield 2 / power return*
- 15 -	X0+	Camera to FG	Data
- 16 -	X1+	Camera to FG	Data
- 17 -	X2+	Camera to FG	Data
- 18 -	Xclk+	Camera to FG	Transmitter Clock
- 19 -	X3+	Camera to FG	Data
- 20 -	SerTC-	FG to Camera	Camera Control (RS232)
- 21 -	SerTFG+	Camera to FG	Camera Control (RS232)
- 22 -	CC1+	FG to Camera	Exsync
- 23 -	CC2-	FG to Camera	Prin (not used)
- 24 -	CC3+	FG to Camera	External Camera Clock
- 25 -	CC4-	FG to Camera	nc
- 26 -	GND / 12 V	-	Shield 4 / 12 V power *

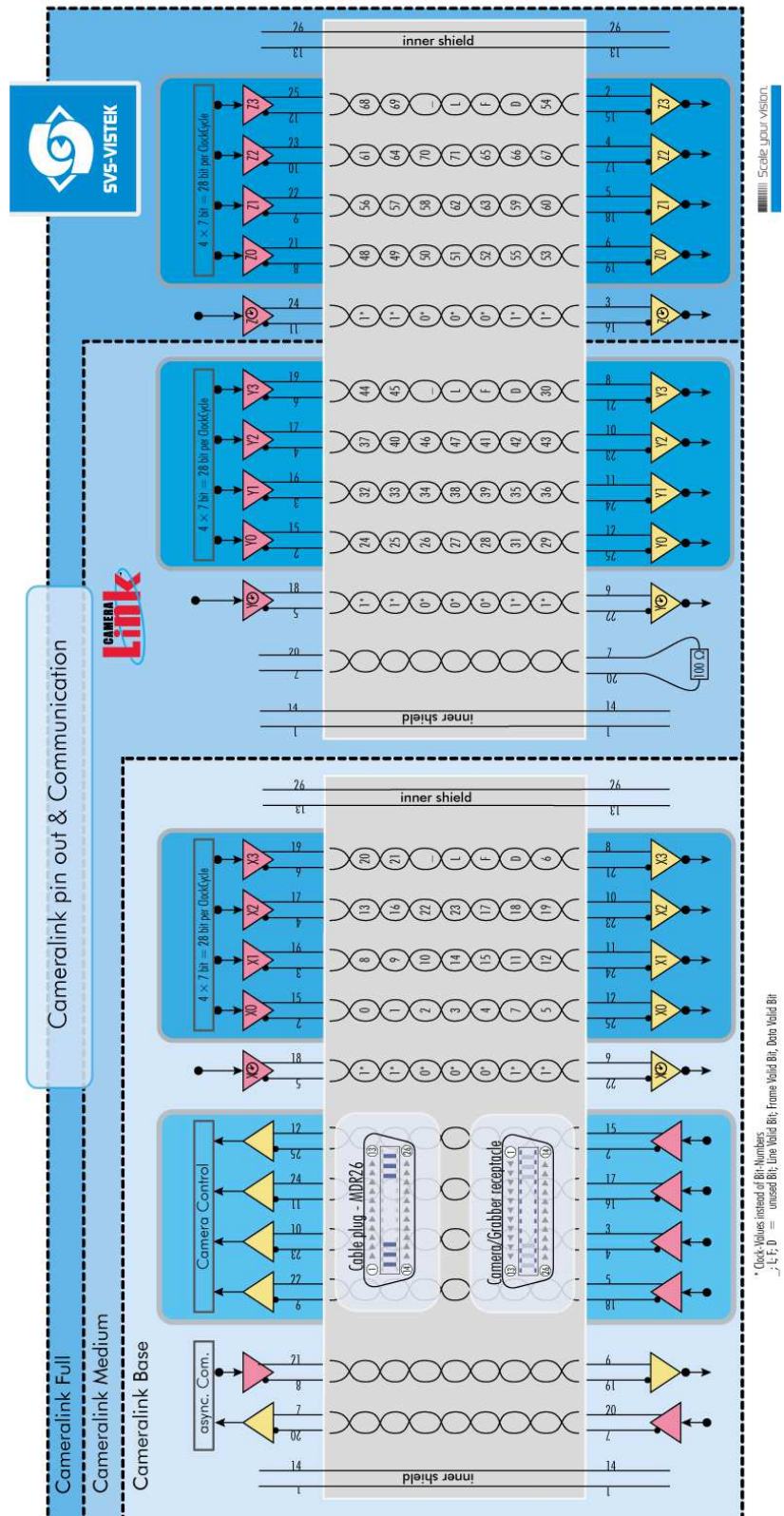

Cameralink pin out & Communication



Scale your vision

3.2 Input / output connectors

Hirose™ 12Pin

The Hirose connector provides the connectors to power, inputs and outputs. For detailed information about switching lights from inside the camera, refer to [strobe control](#).

Hirose 12 Pin

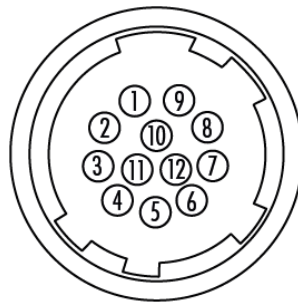

1	VIN –	(GND)
2	VIN +	(10V to 25V DC)
3	IN4	(RXD RS232)
4	OUT4	(TXD RS232)
5	IN1	(0-24V)
6	IN2	(0-24V)
7	OUT1	(open drain)
8	OUT2	(open drain)
9	IN3 +	(opto In +)
10	IN3 –	(opto In –)
11	OUT3	(open drain)
12	OUT0	(open drain)

Specification

Type	HR10A-10R-12P
Mating Connector	HR10A-10P-12S

4 The EXO

The EXO series is a series of machine vision cameras for the low and mid-range resolutions up to 20 MP. The EXO is available with different industry standard interfaces such as GigE Vision, Camera Link and USB3 Vision.

The EXO is easy to integrate and comes with a full package of useful hardware features.

The EXO-Series comes in a new 50 x 50 mm aluminum body. The elaborate, high precision machined unibody housing ensures perfect temperature distribution even for the most demanding sensors. A massive lens mount is designed to keep any kind of lens in its proper position. The electric circuitry of the EXO is optimized for low power dissipation, helped by the excellent temperature performance of the housing. The EXO features the latest global shutter CMOS and CCD sensors from SONY, CMOSIS and ON Semi.

A uniform form factor and identical standard interface connectors with identical pinout facilitate camera model interchangeability, allowing system integrators to adapt applications with varying conditions and requirements very quickly with minimum design effort.

Camera Link Features

Camera Link is the most direct interface connection to the camera sensor and preferred by integrators with high demands on bandwidth and especially low and defined latency times. Camera Link provides a deterministic timing of the camera, what is different to all other interface types.

As operating Camera Link always involves a frame grabber, the specs given in the [specifications](#) might differ from your setup. Please contact us for a recommendation of frame grabbers.

Depending on your camera model, following Camera Link specifics might apply (Please refer to the technical data of your specific camera model):

- > There are different transfer rates with different camera link types. Camera Link full (80 bit technology) is also known as "Camera Link Deca"
- > Some models support Power over Camera Link (PoCL). Please note, in case you use the 4IO PWM outputs to drive your lights, you need an external power supply as the PoCL is unable to deliver the high currents requested.

Some cameras and frame grabbers support 1x3 tap configuration. With this special tap configuration you might achieve higher framerates (up to 50% faster) than in specs. You find the 1x3 capabilities of your camera in the specification of your camera model. Contact us for recommended frame grabbers.

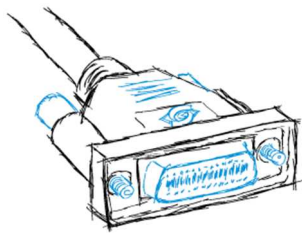

4IO adds Light and Functionality

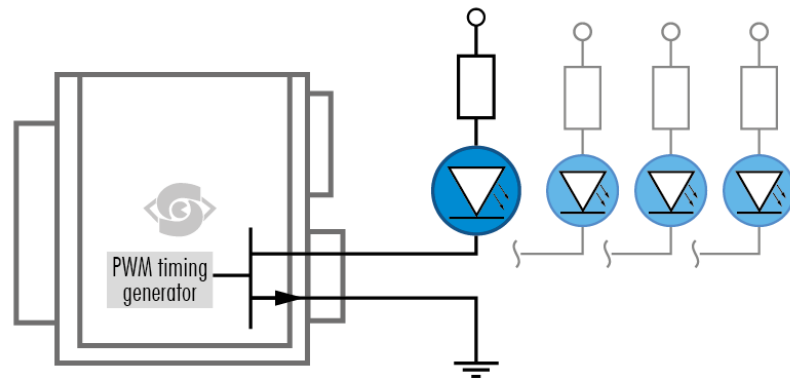

4IO concept with up to 4 switching LED lights

Your SVS-Vistek camera is equipped with the innovative 4IO-interface allowing full light control, replacing external strobe controllers. Each of the outputs can be individually configured and managed using pulse-width modulation. With its high current output, the camera is able to drive LED lights directly without external light controller.

The integrated sequencer allows multiple exposures with settings to be programmed, creating new and cost effective options. Logical functions like AND / OR are supported.

- > Up to 4 x open drain high power OUT
- > Up to 4 x high voltage IN – TTL up to 25 Volts
- > Power MOSFET transistors
- > PWM strobe control
- > Sequencer for various configurations
- > PLC functionality with AND, OR and timers
- > Safe Trigger (debouncer, prescaler, high low trigger)

Find an example how to operate light control in the [sequencer](#) section.

5 Feature description

This chapter covers features of SVCam cameras. Not every feature might be supported by your specific camera model. For information about the features of your specific model, please refer to the specifications area with your exact model.

5.1 Basics

5.1.1 Global shutter

The shutter is describing the functionality of exposing the light sensitive pixels of the sensor to light for a limited time. With global shutter all pixels are exposed to light at the same time for the same time.

All pixel will be exposed to light at the same starting point, and all pixel light exposure will stop at the same time. Fast moving objects will be captured without showing movement distortion, except motion blur if the moving object is so fast that the same point of the object covers different pixels at start and end while exposing.

Using flash with global shutter is straight forward: just make sure your flash is on while shutter is open, thus all pixels are exposed to light the same time. You might flash at any time within exposure time.

5.1.2 Rolling Shutter

Rolling shutter is a method of reading out a CMOS sensor, where the whole scene is scanned line after line very rapidly. Rolling shutter cameras in general are more sensitive in their light response than global shutter ones.

Despite the speed of scanning one line after the other („rolling“) is very high, it is important to note that the instant of imaging a single line will be different to the point of time of the next line imaging. As this works out without any effect in the final image with still sceneries, with moving objects you get geometric distortions (see example of rotating propeller), showing fast moving structures in an predictable, in the first moment yet surprising way.

As it takes some time to read out a whole sensor (and the whole sensor has always to be read out!) you need to make sure that light conditions are stable while reading the sensor. This restriction applies especially to using PWM driven lights or flash lighting with rolling shutter. Unstable light conditions will result in a horizontal line structured pattern noise.



propeller w/ rolling shutter artifacts

Light control with rolling shutter

Scanning sensor lines takes time. Not all sensor lines are sensitive to light at the same time. Make sure your light is ON as long any pixel are going to be exposed. An exo183xCL i.e. needs about 120ms of minimal scanning time.

There are 2 general guidelines for flashing with rolling shutter:

1. Make sure your light is ON and stable **the whole** period of time while scanning/exposing. Minimum flash time is scanning time plus exposure time. In this case, while flashing you will get geometric distortions as mentioned above. Exposure will be determined by camera exposure time and light intensity
2. If flash time is less than scanning time then exposure time has to be at least scanning time + flash time, with a delay of scanning time. In other words, your exposure time will be scanning time plus flash time, while you use a flash delay of scanning time. Thus flash release will start after the delay of scanning time, as soon the sensor is fully open. You should keep the object in total darkness while the first scanning time. In this case, as all lines are sensitive to light at the same time after the first scan time, flashing time can be as short as you like. You will not see the typical geometric rolling shutter distortions as shown above. Imaging will be similar to global shutter. Exposure will be determined by flash time/intensity.

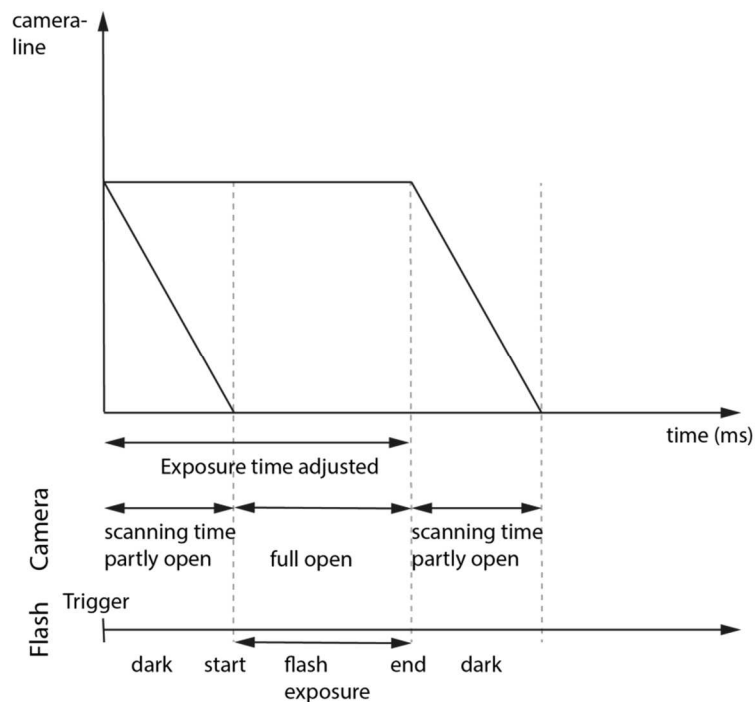

Rolling shutter lines light sensitivity versus time

As shown here, after triggering only part of the sensor is sensitive to light (scanning time). As soon as scanning time has finished, all pixels are sensitive to light, the sensor is fully open. While being fully open this is the time where flashing should happen. In the final scanning time, less and less pixels are sensitive to light until the sensor light sensitivity will finish.

Flashing of rolling shutter sensors is significantly different to global shutter flashing!

PWM lights with rolling shutter

PWM (Pulse Width Modulated) powered light or dimmed light is run at a fixed frequency. Experience teaches us this frequency might be less stable than expected. Unstable frequency might show up as unstable light, creating noise/line structures in the final rolling shutter image (in global shutter images the whole image is just more/less bright)

As a rule of thumb, make sure your PWM lighting frequency is **at least** double or triple the bitdepth of your image (e.g. 8bit image = 256, this means your PWM has to be switched at least $256*2=512$ times) while exposing. If exposure time is 5ms,

Required minimum PWM freq = $5\text{ms}/512 \sim 10\mu\text{s} \sim 100\text{kHz}$

If you have the possibility to use a strobe controller or dimmer with linear regulation, this might be preferable on short exposure times.

Rolling shutter limitations

Due to the principles of rolling shutter, some standard features of SVS-Vistek cameras are not applicable.

- > External exposure control (expose while trigger signal active) does not make sense with rolling shutter
- > ROI with rolling shutter
With rolling shutter the whole sensor has to be read out – always. That means applying ROI will reduce the amount of final data being transmitted out of the camera (and the framerate might rise, due to the limited bandwidth of the interface). Nonetheless, the maximum achievable framerate with applied ROI will be the maximum framerate of the sensor reading the full sensor area (internal full sensor speed), please refer to relating sensor specs.

Calculate Framerates

According to the calculation as below, the requested times for scanning through all lines of the sensor will affect maximum framerate calculation as well.

In this example, the camera is an exo183 with 3672 lines and 54 dummy lines. Each line takes 22.2 ms readout time (depending on CameraLink tap configuration). The camera does have about $300\mu\text{s}$ exposure time delay at worst case.

Framerate calculation with exo183CCL with rolling shutter			
lines			3672
dummy lines		+	54
total lines			<u>3726</u>
readout time 1x3_1Y	22,2 μs	* 3726 =	82717,2 μs
exp delay		+	300 μs
frame readout time			<u>83017,2 μs</u>
This is minimum time for camera readout with 0s exposure time.			
Exposure time has to be added:			
frame readout time			83017,2 μs
exposure time			<u>2500 μs</u>
total frame time			<u>85517,2 μs</u>
maximum sensor acquisition time	1/ frame time		<u>11,6 fps</u>
note: readout time 1x2_1Y = 32,63 μs			

5.1.3 Exposure

See various exposure and timing modes in chapter: [Basic capture modes](#).

Combine various exposure timings with PWM LED illumination, refer to [sequencer](#).

Setting Exposure time

Exposure time can be set by width of the external or internal triggers or programmed by a given value.

5.1.4 Exposure speed

Frames per second, or frame rate describes the number of frames output per second (1/ frame time). Especially GigE and USB cameras cannot guarantee predictable maximum framerates with heavy interface bus load.

Maximum frame rate might depend on

- > Pixel clock
- > Image size
- > Tap structure
- > Data transport limitation
- > Processing time

Limitations exo183 on exposure time

In general, the SVS-specific camera design permits framerates close to this formula:

$$\text{Fps_max} = 1 / \text{exposuretime}$$

The exo183 has some specific sensor properties. Most important, due to its sensor design it comes with an additional readout time of about 56ms. Thus, the maximum exo183 framerate calculates as follows (as long not restricted by interface speed):

$$\text{Fps_max} = 1 / (\text{exposuretime} + 56\text{ms})$$

The implication is that if you want to have full speed in frames per second, with the exo183 sensor you need to take care for short exposure times.

5.1.5 Acquisition and Processing Time

The camera has to read the sensor, process the data to a valid image and transfer this to the host computer. Some of these tasks are done in parallel. This implies the data transfer does not end immediately after end of exposure, as the image has to be processed and transferred after exposure.

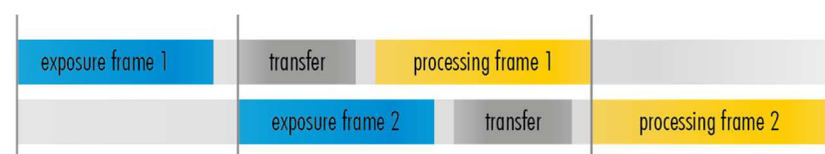

On the other side, while processing and transferring the image the sensor might capture already the next frame.

5.1.6 Auto exposure

Auto Luminance or auto exposure automatically calculates and adjusts exposure time and gain, frame-by-frame.

The auto exposure or automatic luminance control of the camera signal is a combination of an automatic adjustment of the camera exposure time (electronic shutter) and the gain.

The first priority is to adjust the exposure time and if the exposure time range is not sufficient, gain adjustment is applied. It is possible to pre-define the range (min. / max. -values) of exposure time and of gain.

The condition to use this function is to set a targeted averaged brightness of the camera image. The algorithm computes a gain and exposure for each image to reach this target brightness in the next image (control loop). Enabling this functionality uses always both – gain and exposure time.

Limitation

As this feature is based on a control loop, the result is only useful in an averaged, continuous stream of images. Strong variations in brightness from one image to next image will result in a swing of the control loop. Therefore it is not recommended to use the auto-luminance function in such cases.

5.1.7 Bit-Depth

Values of brightness are internally represented by numbers. The number of bits for brightness representation is limiting the number of colour values that can be represented. Bit depth defines the maximum unique colors or grey levels in an image.

No of grey values = $2^{\text{bit depth}}$

All SVCam models support 8-bit format. In most cases, the sensor itself is limiting maximum bit depth. Refer to specifications whether your model is supporting higher bit depth.

5.1.8 Color

Color cameras are identical to the monochrome versions. The color pixels are transferred in sequence from the camera, in the same manner as the monochrome, but considered as “raw”-format.

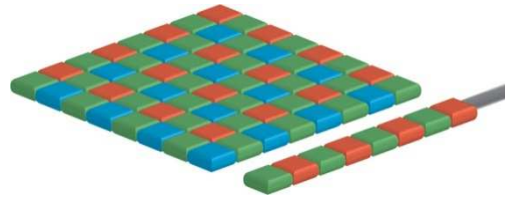

CCD with Bayer Pattern

The camera sensor has a color mosaic filter called “Bayer” filter pattern named after the person who invented it. The pattern alternates as follows:

E.g.: First line: GRGRGR... and so on. (R=red, B=blue, G=green)
 Second line: BGBGBG... and so on. Please note that about half of the pixels are green, a quarter red and a quarter blue. This is due to the maximum sensitivity of the human eye at about 550 nm (green). De-Bayering is not done in the camera, it has to be done in the client software. See SDK functions as well. Not all sensors do have the same sequence of color. The GenlCam property **PIXELCOLORFILTER** does indicate the sequence of the color pixels when reading color images.

Using color information from the neighboring pixels the RG and B values of each pixel is interpolated by software. E.g. the red pixel does not have **INFORMATION** of green and blue components. The performance of the image depends on the software used.

Camera Link frame grabber need information of the sequence order of the colours. The order depends on sensor type. USB3 and GigE cameras provide this in their XML file.



NOTICE

It is recommended to use an IR cut filter for color applications

White Balance

The human eye adapts to the definition of white depending on the lighting conditions. The human brain will define a surface as white, e.g. a sheet of paper, even when it is illuminated with a bluish light.

White balance of a camera does the same. It defines white or removes influences of a color based on a non-white illumination.

- > **Continuous:** Auto white balance will analyze the taken images and adjust exposure per color accordingly as long as the camera is taking images. Different colors of the same object in a sequence might be the result depending on the other objects in the image
- > **Once:** Auto white balance will adjust white balance as soon it is started and will stop modifying parameters as soon white balance is finished

5.1.9 Resolution

As mentioned in the specifications, there is a difference between the numerical sensor resolution and the camera resolution. Some pixels towards the borders of the sensor will be used only internally to calibrate sensor values (“dark pixels”). The amount of dark current in these areas is used to adjust the [offset](#).

For calculating image sizes, the maximum camera resolution is determining maximum image resolution. See [specifications](#) of your model.

5.1.10 Offset

For physical reasons the output of a sensor will never be zero, even the camera is placed in total darkness or simply closed. Always there will be noise or randomly appearing electrons that will be detected as a signal (dark noise: noise generated without light exposure).

To avoid this dark noise to be interpreted as a valuable signal, an offset will be set.

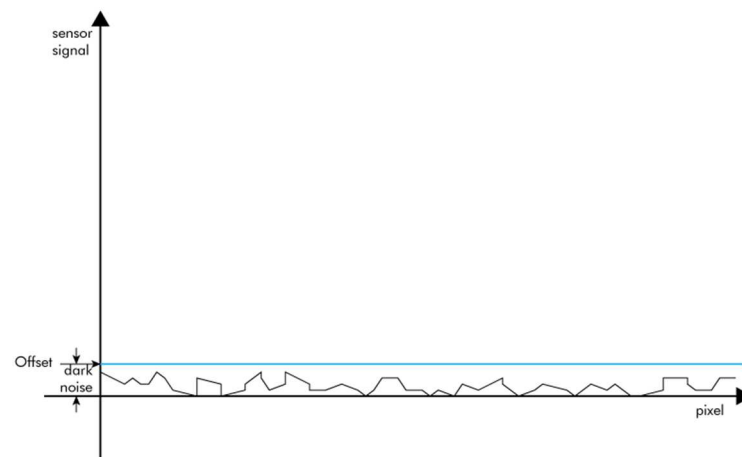

dark noise cut off by the offset

Most noise is proportional to temperature. To spare you regulating the offset every time the temperature changes. A precedent offset is set by the camera itself. It references certain pixels that never were exposed to light as black. So the offset will be set dynamically and conditioned to external influences.

The offset can be limited by a maximum bit value. If higher values are needed, try to set a look up table.

In case of multi-tap CCD sensors, offset can be altered for each tap separately (see tap balancing).

5.1.11 Gain

Setting gain above 0 dB (default) is a way to boost the signal coming from the sensor. Especially useful for low light conditions. Setting gain amplifies the signal of individual or binned pixels before the ADC. Referring to photography adding gain corresponds to increasing ISO. Increasing gain will increase noise as well.

add 6 dB	double ISO value
6 dB	400 ISO
12 dB	800 ISO
18 dB	1600 ISO
24 dB	3200 ISO

Table of dB and corresponding ISO value



NOTICE

Gain also amplifies the sensor's noise. Therefore, gain should be last choice for increasing image brightness. Modifying gain will not change the camera's dynamic range.

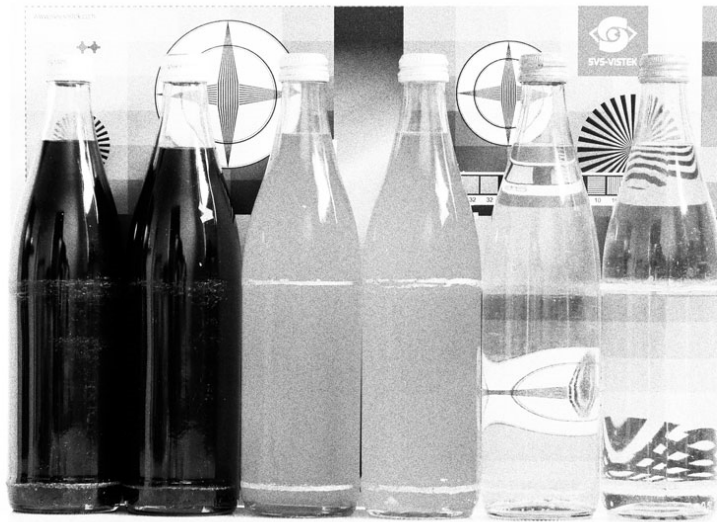

noise caused by too much gain

Auto Gain

For automatic adjustment of Gain please refer to [auto exposure](#).

When using autogain with steps of gain the non-continuous gain adjustment might be visible in final image. Depending on your application it might be preferable to use fixed gain values instead and modify exposure with exposure time.

5.1.12 Flip Image

Images can be mirrored horizontally or vertically. Image flip is done inside the memory of the camera, therefore not increasing the CPU load of the PC.



original image



horizontal flip



vertical flip

5.1.13 Binning

Binning provides a way to enhance dynamic range, but at the cost of lower resolution. Binning combines electron charges from neighboring pixels directly on the chip, before readout.

Binning is only used with monochrome CCD Sensors. For reducing resolution on color sensors refer to [decimation](#).

On CMOS sensors, binning will not affect image quality. In any case, binning will reduce the amount of pixel data to be transferred.

Vertical Binning

Accumulates vertical pixels.

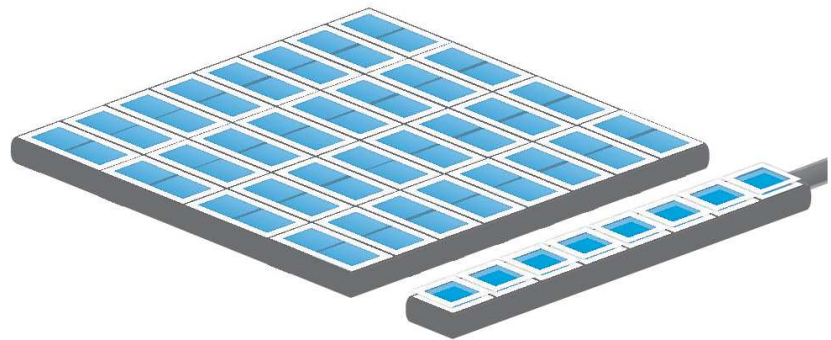

Vertical binning

Horizontal Binning

Accumulates horizontal pixels.

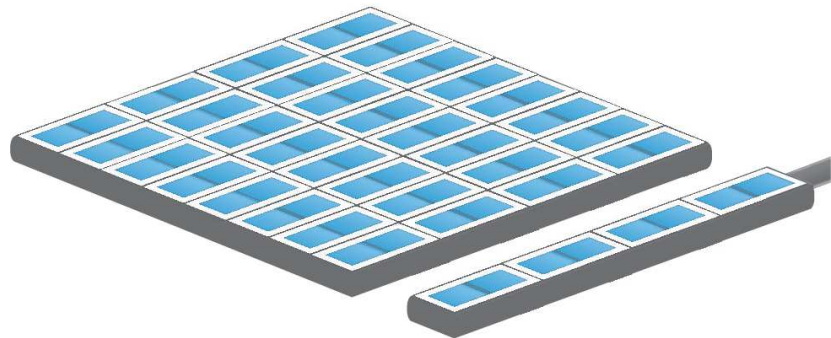

Horizontal binning

2×2 Binning

A combination of horizontal and vertical binning.

When DVAL signal is enabled only every third pixel in horizontal direction is grabbed.

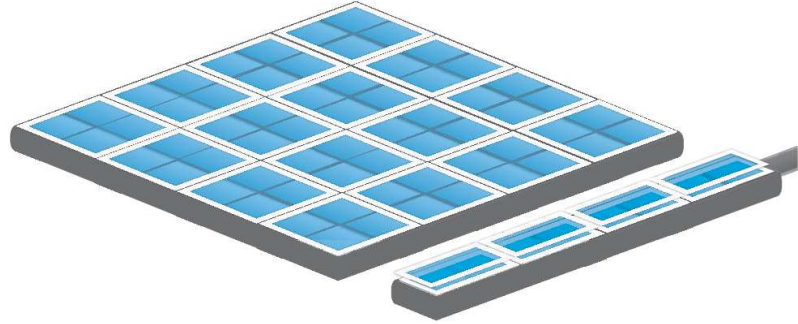

2x2 binning

5.1.14 Decimation

For reducing width or height of an image, decimation can be used. Columns or rows can be ignored.

Refer to AOI for reducing data rate by reducing the region you are interested in.



Horizontal decimation



Vertical decimation

Decimation on Color Sensors

The Bayer pattern color information is preserved with 1/3 horizontal and vertical resolution. The frame readout speed increases approx. by factor 2.5.

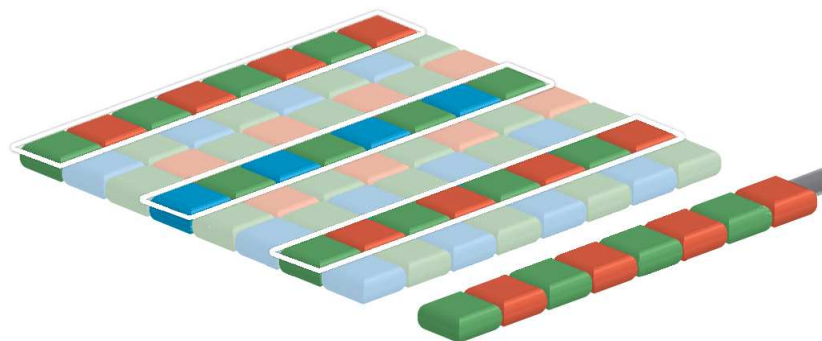

Decimation on color sensors

5.2 Camera Features

5.2.1 Basic Capture Modes

Free Running

Free running (fixed frequency) with programmable exposure time. Frames are readout continuously and valid data is indicated by LVAL for each line and FVAL for the entire frame.

Mode 0: Free Running with Programmable Exposure Time

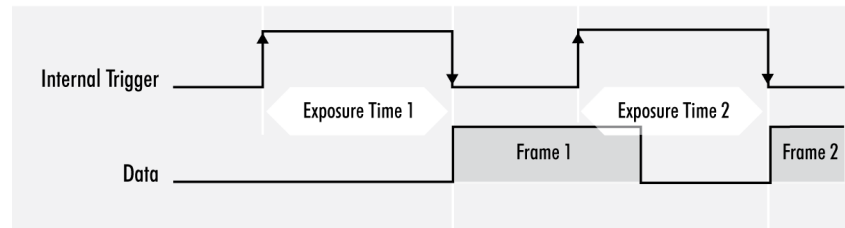

There is no need to trigger the camera in order to get data. Exposure time is programmable via serial interface and calculated by the internal logic of the camera.



NOTICE

The fundamental signals are:
 Line Valid: LVAL, Frame Valid: FVAL,
 And in case of triggered modes: trigger input.

Triggered Mode (pulse width)

External trigger and pulse-width controlled exposure time. In this mode the camera is waiting for an external trigger, which starts integration and readout. Exposure time can be varied using the length of the trigger pulse (rising edge starts integration time, falling edge terminates the integration time and starts frame read out). This mode is useful in applications where the light level of the scene changes during operation. Change of exposure time is possible from one frame to the next.

Mode 1: External Trigger with Pulse Width Exposure Control (overlap)

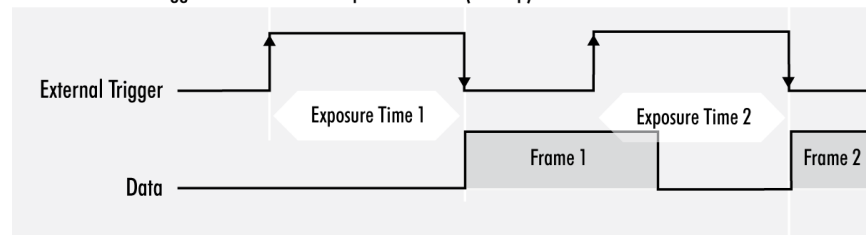

Exposure time of the next image can overlap with the frame readout of the current image (rising edge of trigger pulse occurs when FVAL is high). When this happens: the start of exposure time is synchronized to the falling edge of the LVAL signal.

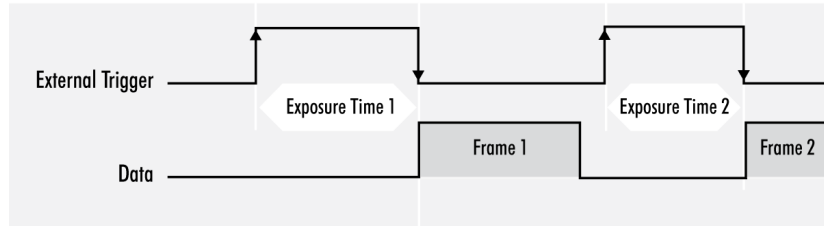
Mode 1: External Trigger with Pulse Width Exposure Control (non overlap)

When the rising edge of trigger signal occurs after frame readout has ended (FVAL is low) the start of exposure time is not synchronized to LVAL and exposure time starts after a short and persistent delay.

The falling edge of the trigger signal must always occur after readout of the previous frame has ended (FVAL is low).

Software Trigger

Trigger can also be initiated by software (serial interface).



NOTICE

Software trigger can be influenced by jitter. Avoid Software trigger at time sensitive applications

External Trigger (Exposure Time)

External trigger with programmable exposure time. In this mode the camera is waiting for an external trigger pulse that starts integration, whereas exposure time is programmable via the serial interface and calculated by the internal microcontroller of the camera.

At the rising edge of the trigger the camera will initiate the exposure.

The software provided by SVS-Vistek allows the user to set exposure time e.g. from 60 μ s 60 Sec (camera type dependent).

Exposure time of the next image can overlap with the frame readout of the current image (trigger pulse occurs when FVAL is high). When this happens, the start of exposure time is synchronized to the negative edge of the LVAL signal (see figure)

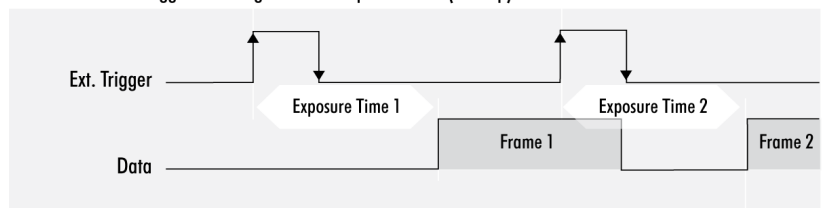
Mode 2: External Trigger with Programmable Exposure Time (overlap)

When the rising edge of trigger signal occurs after frame readout has ended (FVAL is low), the start of exposure time is not synchronized to LVAL and exposure time starts after a short and persistent delay.

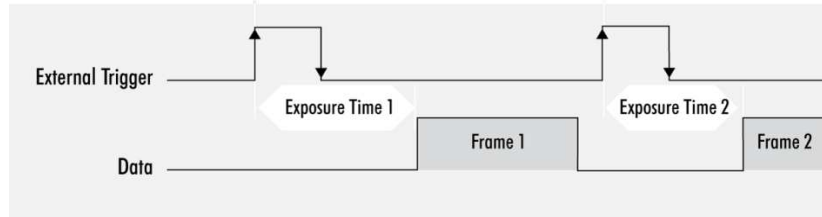
Mode 2: External Trigger with Programmable Exposure Time (non overlap)

Exposure time can be changed during operation. No frame is distorted during switching time. If the configuration is saved to the EEPROM, the set exposure time will remain also when power is removed.

Detailed Info of External Trigger Mode

Diagrams below are equivalent for CCD and CMOS technique.

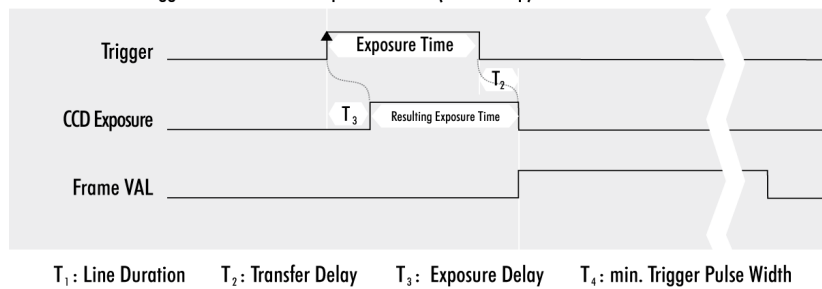
Mode 1: External Trigger with Pulse Width Exposure Control (non overlap)

Mode 1: External Trigger with Pulse Width Exposure Control (overlap)

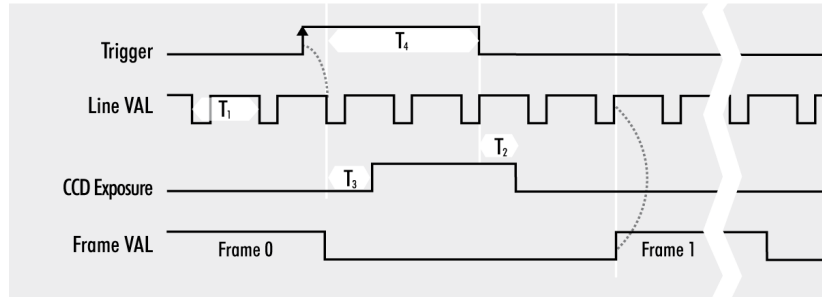

T_1 : Line Duration T_2 : Transfer Delay T_3 : Exposure Delay T_4 : min. Trigger Pulse Width

Mode 2: External Trigger with Programmable Exposure Time (non overlap)

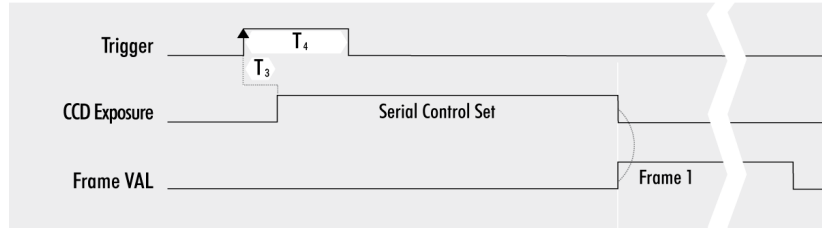

T_1 : Line Duration T_2 : Transfer Delay T_3 : Exposure Delay T_4 : min. Trigger Pulse Width

Mode 2: External Trigger with Programmable Exposure Time (overlap)

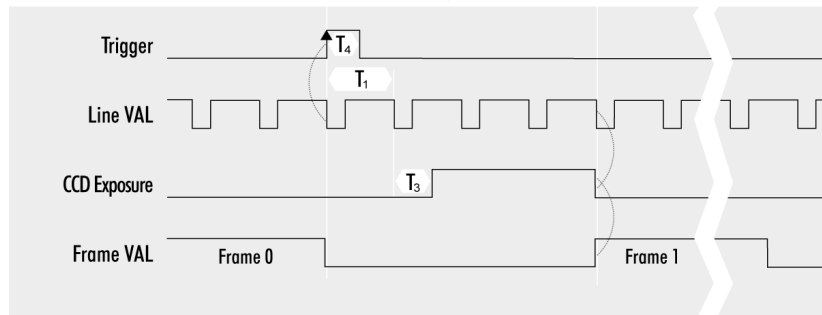

T_1 : Line Duration T_2 : Transfer Delay T_3 : Exposure Delay T_4 : min. Trigger

5.2.2 System Clock Frequency

Default system clock frequency in almost every SVCam is set to 66.6 MHz. To validate your system frequency refer to: [specifications](#).

Using the system clock as reference of time, time settings can only be made in steps. In this example, the transfer rate is 66.7 MHz, thus resulting in steps of 15 ns.

$$t = \frac{1}{66.6 \text{ MHz}} = \frac{1}{66\,666\,666.6 \frac{1}{s}} = 15 \cdot 10^{-9} \text{ s} = 15 \text{ ns}$$



NOTICE

Use multiples of 15 ns to write durations into camera memory

5.2.3 Temperature Sensor

A temperature sensor is installed on the mainboard of the camera.

To avoid overheating, the temperature is constantly monitored and read. Besides software monitoring, the camera indicates high temperature by a red flashing LED. (See flashing LED codes)

5.2.4 Camera Link timings

It might be interesting to know when “valid data” can be expected exactly.

px_h = pixel horizontal [count]

px_v = pixel vertical [count]

LVAL – t_{Lvd}

Every line has periods with no valid data. The Duration of None Valid Data between two lines (t_{nvd}) is three time the Camera Link clock (clk). Delay before every first line is 2 times clk.

$$t_{Lvd} = \frac{px_h}{CL_geometry_X} \times \frac{1}{CL_clock}$$

CL_clock = 85 MHz

FVAL – t_{Fvd}

Frames are not sent permanently. Between two frames will be a gap – even at highest frame rates. Minimum duration between two valid frame signals is the duration of one line.

$$t_{Fvd} = 2 \times \frac{1}{CL_clock} + (t_{Lvd} + t_{nvd}) \times \frac{px_v}{CL_geometry_Y}$$

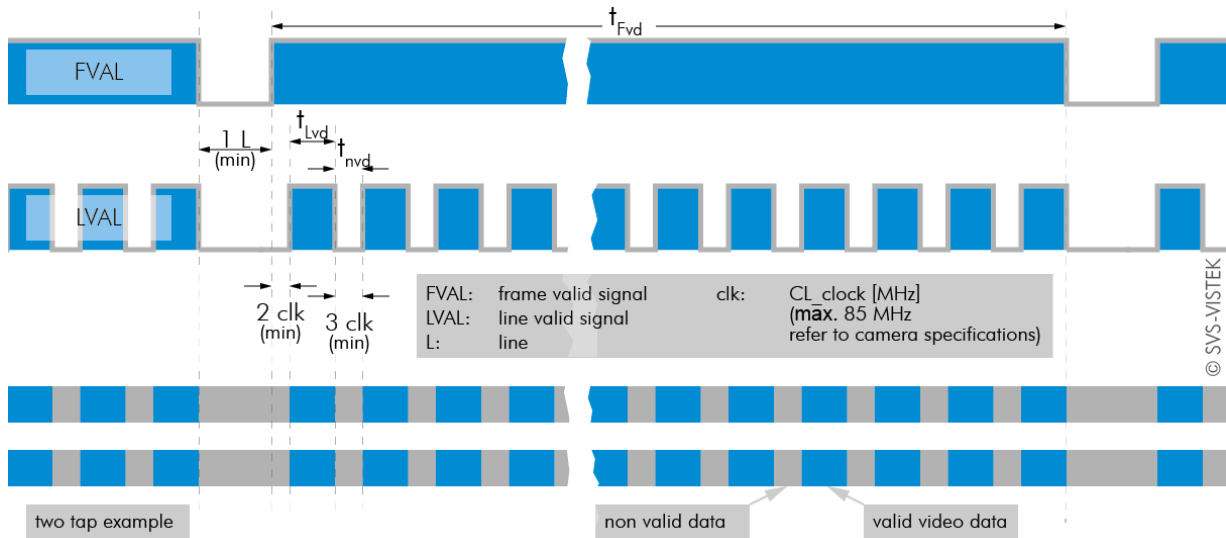

overview of FVAL and LVAL signal timing on Camera Link

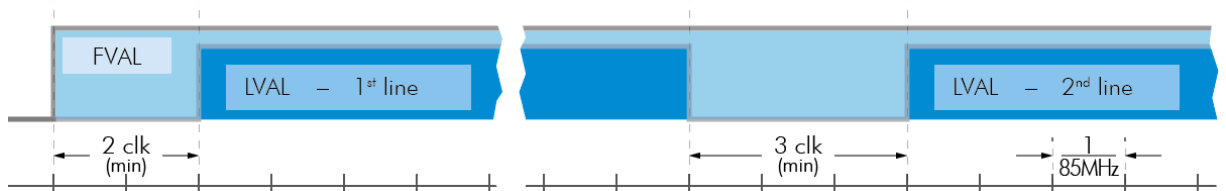

more detailed view of LVAL signal timing on Camera Link

Example calculation		on exo174*CL	
>	$t_{Lvd} = \frac{(1920 / 2)}{\text{px in line / sent at once}} \times \frac{(1/85\text{MHz})}{\text{CL_clock}}$ $= \frac{960}{960} \times \frac{(1/85e^6) \text{ s}}{(1/85e^6) \text{ s}}$		$\approx 11,29 \mu\text{s}$
>	$t_{nvd} = \frac{3 \times (1/85\text{MHz})}{\text{time between two valid line data packages}}$		$\approx 35,3 \text{ ns}$
>	$t_{Fvd} = \frac{2 \times (1/85\text{MHz})}{\text{delay before first line}} + (t_{Lvd} + t_{nvd}) \times \frac{1200}{\text{lines [count]}}$ $= \frac{(2/85e^6) \text{ s}}{(2/85e^6) \text{ s}} + (11,29 \mu\text{s} + 35,3 \text{ ns}) \times 1200$ $= 23,5 \text{ ns} + (11,29 \mu\text{s} + 35,3 \text{ ns}) \times 1200$ $= \frac{(2 + (960 + 3) \times 1200) \text{ s}}{85e^6} \approx 13,6 \text{ ms}$		
Camera Link architecture exo174*CL: 1X2_1Y count = 2 pixelh = 1920 pixelv = 1200 CL_clock = 85 MHz			

example calculation of Camera Link timing on a exo174*CL

5.2.5 LookUp Table

The LookUp Table Feature (LUT) lets the user define certain values to every bit value that comes from the ADC.

To visualize a LUT a curve diagram can be used, similar to the diagrams used in photo editing software.

The shown custom curve indicates a contrast increase by applying an S-shaped curve. The maximum resolution is shifted to the mid-range. Contrasts in this illumination range is increased while black values will be interpreted more black and more of the bright pixels will be displayed as 100 % white...

For further Information about curves and their impact on the image refer to our homepage: [Knowledge Base – LUT](#)

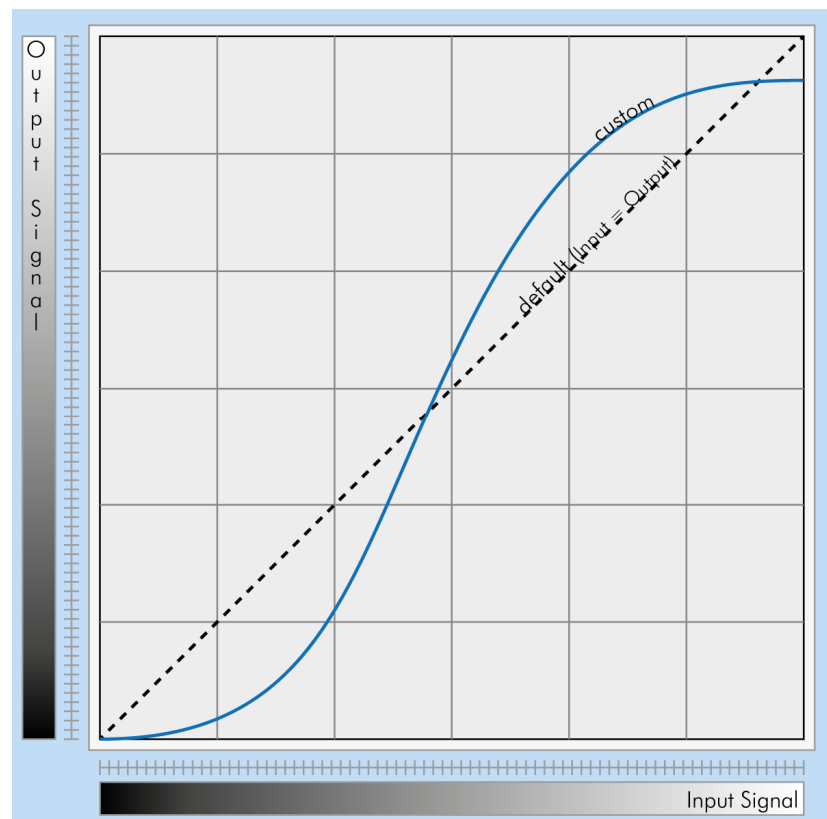

Figure 1: Custom LUT adding contrast to the midtones



NOTICE

LUT implementation reduces bit depth from 12 bit to 8 bit on the output.

Gamma Correction

Using the LookUp Table makes it also possible to implement a logarithmic correction. Commonly called Gamma Correction.

Historically Gamma Correction was used to correct the illumination behavior of CRT displays, by compensating brightness-to-voltage with a Gamma value between 1,8 up to 2,55.

The Gamma algorithms for correction can simplify resolution shifting as shown seen above.

Input & Output signal range from 0 to 1

$$\text{Output-Signal} = \text{Input-Signal}^{\text{Gamma}}$$

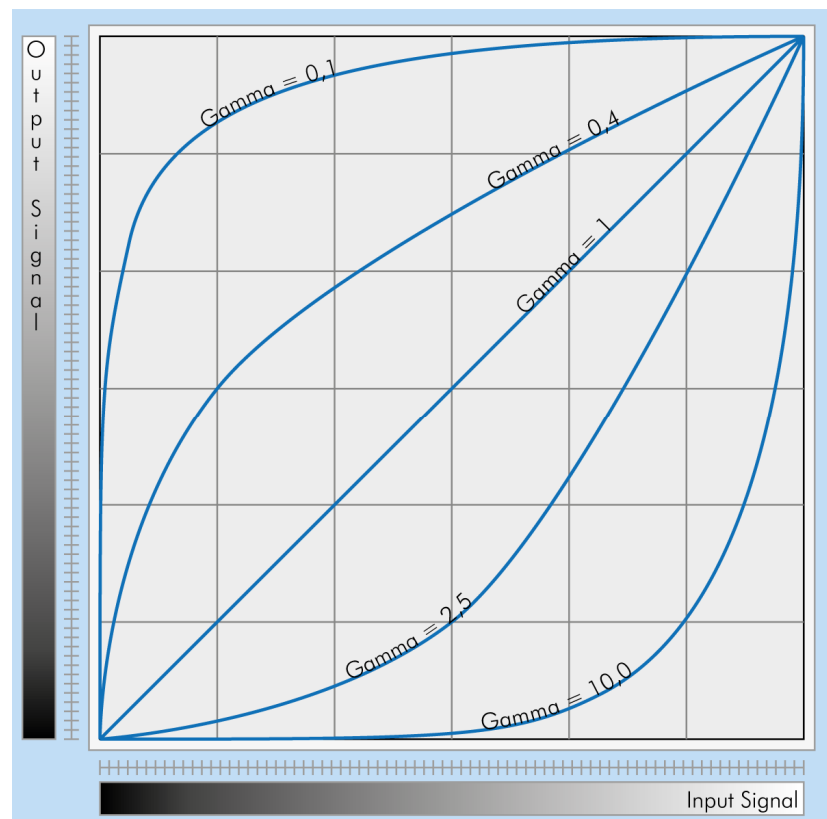

Figure 2: Several gamma curves comparable to a LUT

Gamma values less than 1.0 map darker image values into a wider ranger.

Gama values greater than 1.0 do the same for brighter values.



NOTICE

Gamma Algorithm is just a way to generate a LUT. It is not implemented in the camera directly..

5.2.6 ROI / AOI

In Partial Scan or Area-Of-Interest or Region-Of-Interest (ROI) -mode only a certain region of the sensor will be read.

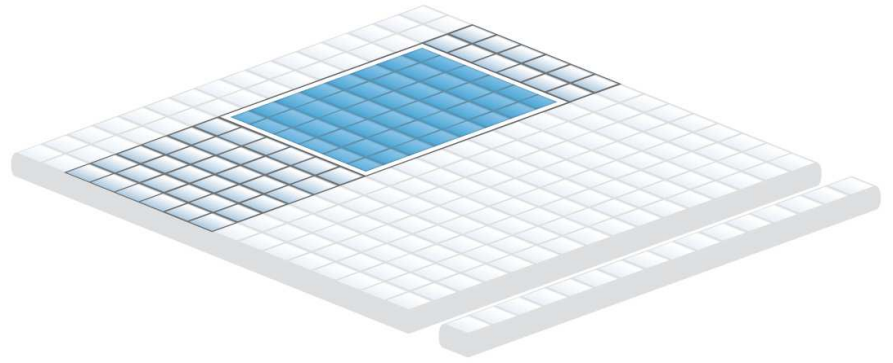

AOI on a CCD sensor

Selecting an AOI will reduce the number of horizontal lines being read. This will reduce the amount of data to be transferred, thus increasing the maximum speed in term of frames per second.

With CCD sensors, setting an AOI on the left or right side does not affect the frame rate, as lines must be read out completely.

With CMOS Sensors, AOI is sensor dependant. Some CMOS sensors require the camera to read full horizontal sensor lines internally. Reducing horizontal size with AOI might result in limited framerate gain.

ROI sizes

Sensors do have special requirements regarding the sizing of regions of interest. Please find below restrictions for your sensor type

camera	sensor	Bit depth	smallest ROI	Width step x	Height step y	Offset x	Offset y
exo	Sony IMX	8	128x2	8	2	8	2
exo	Sony IMX	12	128x2	16	2	8	2
exo814CU3	ICX814	8	16x16	8	1	8	2
exo814CU3	ICX814	12	16x16	16	1	16	2
exo4000CGE	CMV4000	8	32x32	8	2	8	2
exo4000CGE	CMV4000	12	32x32	16	2	8	2

5.2.7 Pixel Clock Frequency Selection

Besides the factory frequency setting other values can be available for CCD sensors. Please contact us in case you need higher pixel clock.

Charges will be transported faster, more frames per second will be generated.

Default value is as recommended in [sensor specifications](#).



NOTICE

Higher Frequencies can result in a loss of quality.

5.2.8 IR / glass filter

To avoid influences of infrared light to your image, cameras are equipped with an IR (Infrared) cut filter or an anti-reflection coated glass (AR filter).

- > Monochrome cameras come by default with an AR-Filter (anti reflex)
- > Color models version comes by default with an IR-cut-filter

Please refer to your camera order to see if a filter is built in. Alternatively take a close look on the sensor. Built-in IR-filters are screwed into the lens mount. Filters will change the optical path length. The camera specs are including the standard filters.

Image impact of IR cut filter

Due to chromatic aberration, limiting the spectral bandwidth of light will result in sharper images. Without an IR cut filter:

- > Monochrome sensor images might get muddy.
- > Color sensor images are affected, especially red will be higher in intensity than visible with bare eyes. White balance gets much more difficult. Contrast is lower.

SVS-VISTEK recommends IR cut filter for high demands on sharpness with monochrome or color sensors.

Spectral impact of IR cut filters

IR cut filter do influence the spectral sensitivity of the sensor. The spectral graph below shows the wavelength relative impact of the SVS-VISTEK standard filter.

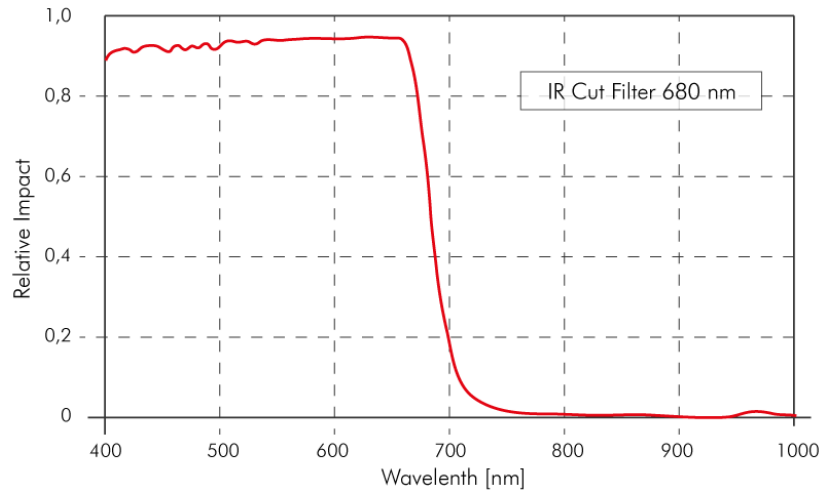

IR cut filter light transmission

Focal impact of filters

As an IR cut filter mainly consist of a small layer of glass (1 mm thick) there is an impact on the flange focal distance. Refraction within the layer cause shortening this distance.

When ordering a standard camera with an extra IR cut filter you might have to compensate the focal length with an extra ring. Please refer to your local distributor for more detailed information on your camera behaving on C-Mount integrated filters.

As BlackLine models have an IR cut filter by default, the focal distance is compensated by default.



NOTICE

Removing the IR cut filter lengthen the focal distance and will invalidate camera warranty.

5.3 I/O Features

5.3.1 GenlCam

GenlCam™ provides a generic programming interface to control all kinds of cameras and devices. Regardless of the interface technology (GigE Vision, USB3 Vision, CoaXPress, Camera Link, etc.) or implemented feature, the application programming interface (API) will always be the same. The SNFC makes sure the feature names are similar throughout the manufacturers, making it more easy to switch camera models.



The GenlCam™ standard consists of multiple modules according to the main tasks to be solved:

- > GenApi: configuring the camera
- > SNFC: Standard Feature Naming Convention, a catalogue of standardized names and types for common device features
- > GenTL: transport layer interface, grabbing images
- > GenCP: generic GenlCam control protocol
- > GenTL SFNC: recommended names and types for transport layer interface.

The GenlCam properties are organized as a tree. Manufacturers can add more features.

With your SVCam, the GenlCam tree does have some hardware related extensions, especially in the I/O sector. See the [Quick guide install](#) for a short introduction into SVS-Vistek's GenlCam tree.

5.3.2 PWM

During Pulse Width Modulation (PWM), a duty cycle is modulated by a fixed frequency square wave. This describes the ratio of ON to OFF as duty factor or duty ratio.

Why PWM?

Many electrical components must be provided with a defined voltage. Whether it's because they do not work otherwise or because they have the best performance at a certain voltage range (such as diodes or LEDs).

LED characteristics

Since LEDs have a bounded workspace, the PWM ensures a variable intensity of illumination at a constant current on the diodes. The constant current guarantees a linear light emission response curve of the LED from 0-100% PWM intensity.

Running LED lighting in flash mode will increase LED lifetime because of reduced LED heat dissipation.

Implementation of PWM

The basic frequency of the modulation is defined by the cycle duration "T".

$$T_{PWM} = \frac{1}{f_{PWM}}$$

Duty cycle "T" is written into the registry by multiple of the inverse of camera frequency. (15 ns steps) Refer to: [Time unit of the camera](#).

$$\begin{aligned} T_{PWM} &= \frac{1}{66,6MHz} \cdot PWMMax[SeqSelector] \\ &= 15 ns \cdot PWMMax[SeqSelector] \end{aligned}$$

THE INTENSITY OF A PWM:

That duty ratio is calculated as: $\Delta\% = t / T$. It is written about the value of "t" as PWMChange0-3[SeqSelector] per sequence into the Registry.

PWMChange0-3[SeqSelector] unit is percentage value.

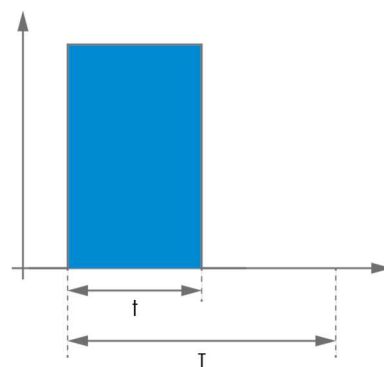

EXAMPLES OF PWMs:

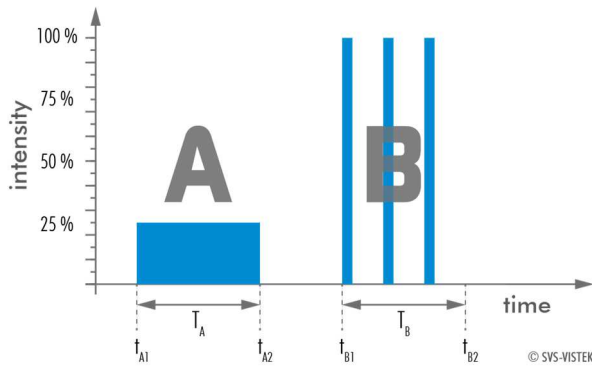

25% PWM load

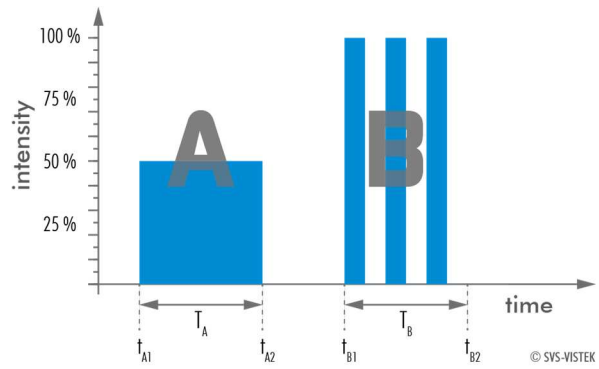

50% PWM load

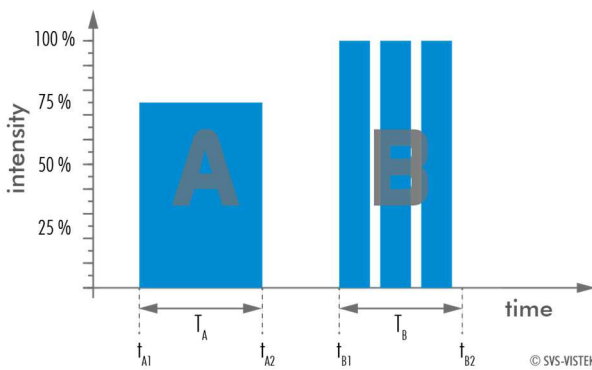

75% PWM load

The integrals over both periods T_A and T_B are equal.

$$\int_{t_{A1}}^{t_{A2}} A = \int_{t_{B1}}^{t_{B2}} B$$

An equal amount of Photons will be emitted. The intensity of light is the same.

$$t_{A2} - t_{A1} = t_{B2} - t_{B1}$$

The periods T_A and T_B are equal in length.

THE PWM MODULE:

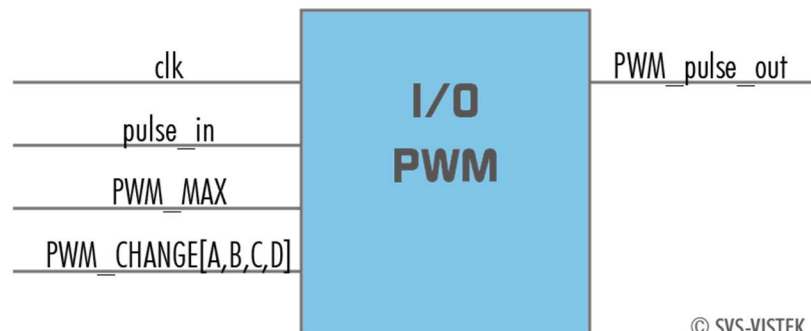

© SVS-VISTEK

5.3.3 Driver Circuit Schematics

Camera power supply and power supply for PWM out is 25V max. Power for PWM out has to be supplied via [Hirose connector](#). The open drain outputs are ledged to ground, that means you connect your LED on the positive side to your (light-)power source, the negative LED connector goes to the camera out. This setup requires common ground.

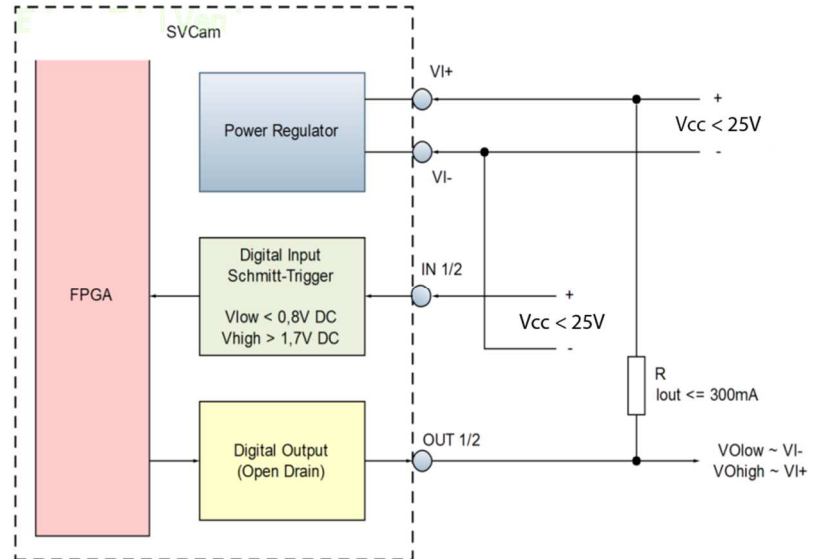

5.3.4 Assigning I/O Lines – IOMUX

The IOMUX is best described as a switch matrix. It connects inputs, and outputs with the various functions of SVCam I/O. It also allows combining inputs with Boolean arguments.

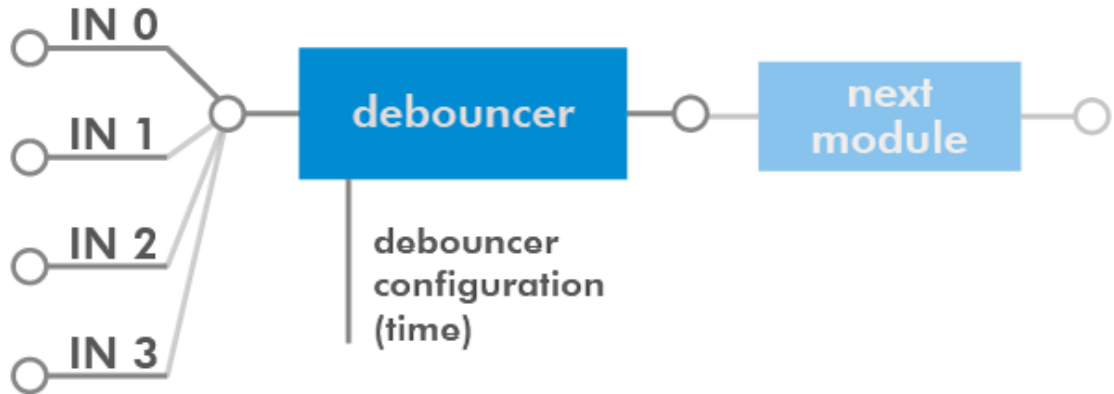

"IN0" connected to "debouncer"

The input and output lines for Strobe and Trigger impulses can be arbitrarily assigned to actual [data lines](#). Individual assignments can be stored persistently to the EPROM. Default setting can be restored from within the Camera.

LineSelector	translation
Line0	Output0
Line1	Output1
Line2	Output2
Line3	Output3
Line3	Output4
Line5	Uart In
Line6	Trigger
Line7	Sequencer
Line8	Debouncer
Line9	Prescaler
Line10	Input0
Line11	Input1
Line12	Input2
Line13	Input3
Line14	Input4
Line15	LogicA
Line16	LogicB
Line17	LensTXD
Line18	Pulse0
Line19	Pulse1
Line20	Pulse2
Line21	Pulse3
Line22	Uart2 In

Note:

If you connect the camera with a non-SVS-Vistek GigEVision client, you might not see the clearnames of the lines, but only line numbers. In this case, use this list of line names

Refer to pinout in [input / output connectors](#) when physically wiring.

input vector to switch matrix

nr.	name	description
0	io_in(0)	trigger input 0 – 24 Volt / RS-232 / opto *
1	io_in(1)	trigger input 0 – 24 Volt / RS-232 / opto *
2	io_in(2)	trigger input 0 – 24 Volt / RS-232 / opto *
3	io_in(3)	trigger input 0 – 24 Volt / RS-232 / opto *
4	io_rxd input	
5	txd_from_uart1	input
6	strobe(0)	output from module iomux_pulseloop_0
7	strobe(1)	output from module iomux_pulseloop_1
8	rr_pwm_out_a	output from module iomux_sequenzer_0
9	rr_pwm_out_b	output from module iomux_sequenzer_0
10	expose input	
11	readout input	
12	r_sequenzer_pulse_a	output from module iomux_sequenzer_0 (pulse)
13	rr_pwm_out_c	output from module iomux_sequenzer_0
14	rr_pwm_out_d	output from module iomux_sequenzer_0
15	r_sequenzer_active	output from module iomux_sequenzer_0
16	r_debouncer	output from module iomux_dfilter_0
17	r_prescaler	output from module iomux_prescaler_0
18	r_sequenzer_pulse_b	output from module iomux_sequenzer_0 (pwm mask)
19	r_logic	output from module iomux_logic_0
20	strobe(2)	output from module iomux_pulseloop_2
21	strobe(3)	output from module iomux_pulseloop_3
22	mft_rxd input	
23	trigger_feedback	input
24	txd_from_uart2	input

* refer to pinout or [specifications](#)

output vector from switch matrix

nr.	name / register	description
0	io_out(0)	output open drain
1	io_out(1)	output open drain
2	io_out(2)	output open drain *
3	io_out(3)	output open drain *
4	io_txd	output, when debug='0'
5	rxd_to_uart1	output (uart_in)
6	trigger	output
7	sequenzer_hw_trigger	input to module iomux_sequenzer_0
8	debounce input	input to module iomux_dfilter_0
9	prescale input	input to module iomux_prescaler_0
10	logic inputa	input to module iomux_logic_0
11	logic inputb	input to module iomux_logic_0
12	mft_txd	output
13	pulseloop_hw_trigger	input to module iomux_pulseloop_0
14	pulseloop_hw_trigger	input to module iomux_pulseloop_1
15	pulseloop_hw_trigger	input to module iomux_pulseloop_2
16	pulseloop_hw_trigger	input to module iomux_pulseloop_3
17	rxd_to_uart2	output (uart2_in)

* for physical number of open drain outputs refer to pinout or [specifications](#)

5.3.5 LED Strobe Control

The SVCam 4I/O concept contains an integrated strobe controller. Its controls are integrated into the GenICam tree. With LED lights attached to the outputs, this enables the user to control the light without external devices. Being controlled via GenICam, any GenICam-compliant 3rd party software is able to control the light as well. Maximum ON-time is 100ms. Depending on the camera model, up to 4 (see [specifications](#)) independent channels are supported with a max current of 3A@40ms . Maximum continuous current is 0.3 A. Despite internal protections, higher current peaks might be able to damage the camera.

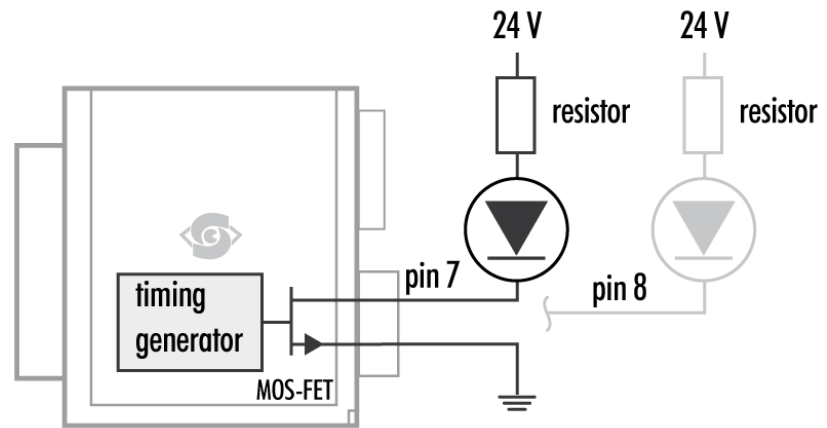

Attach LED lights to camera outputs



USE RIGHT DIMENSION OF RESISTOR!

To avoid destruction of your LED light or camera, make sure to use the right dimension of shunt resistor. If not done so, LEDs and/or Camera might be damaged.

Calculate LED shunt resistors

Shunt resistors are used to limit the LED current. Make sure, neither shunt nor LED run above specs.

LEDs in Continuous Mode

Example Calculation "No Flash" (CW Mode)	
Voltage drop at 5 LEDs, 2,2V per LED (see spec. of LED)	11 V
Max. continuous current (see spec. of LED)	250 mA
Voltage supply	24 V
Voltage drop at resistor (24 V – 11 V)	13 V
Pull up Resistor $R = \frac{13 V}{250 mA}$	52 Ω
<hr/>	
Total power ($P = U \times I$)	6 W
Power at LEDs (11 V \times 250 mA)	2,75 W
Power loss at resistor (13 V \times 250 mA)	3,25 W

LEDs in Flash Mode

Most LED lights can cope with currents higher than specs. This gives you higher light output when light is ON. Please refer to your LED specs if LED overdrive is permitted.

By controlling the duty cycle the intensity of light and current can be controlled. See sequencer example how to adjust the values in the GenICam tree for strobe control.



NOTICE

The shorter the „time on“ – the higher current can be used when driving LEDs with current higher than spec

Strobe vocabulary

For an example how to enable and adjust the integrated strobe controller refer to [sequencer](#). Times and frequencies are set in tics. 1 tic = 15ns.

Exposure Delay

A tic value, representing the time between the (logical) positive edge of trigger pulse and start of integration time.

Strobe Polarity

Positive or negative polarity of the hardware strobe output can be selected.

Strobe Duration

The exposure time of LED lights can be set in **tics**. The min duration is 1 μ sec. The longest time is 1 second.

Strobe Delay

The delay between the (logical) positive edge of trigger pulse and strobe pulse output.

5.3.6 Sequencer

The sequencer is used when different exposure settings and illuminations are needed in a row.

Values to set	Description
Sequencer interval	Duration of the interval
Exposure start	Exposure delay after interval start
Exposure stop	Exposure stop related to interval Start
Strobe start	Strobe delay after interval start
Strobe stop	Strobe stop related to interval Start
PWM frequency	Basic duty cycle (1 / Hz) for PWM
PWM change	Demodulation results

In the current GenlCam implementation, all values have to be entered in tic values.

1 tic = 15 ns

Every adjustment (times, frequencies) has to be recalculated into tics and done in tics. See the example below.

When setting “Exposure Start” and “Stop” consider ‘read-out-time’ of the sensor. It has to be within the Sequencer interval.

For physical input and output connections refer to pinout or specifications or see example below. After trigger signal all programmed intervals will start. Up to 16 intervals can be programmed.

Sequencer settings can be saved to camera EEPROM.

Example

For demonstration, imagine following task to be done:

Scenario

An object should be inspected with a monochrome camera. For accentuating different aspects of the image, 4 images should be taken in a row with 4 different colours of light: Red, Green, Blue, White. White light should be generated from the RGB lights being activated at the same time. Basis is a dark environment without other light sources.

Camera wiring

- 3 LED lights are physically connected to the camera on out 0-2 (red, green, blue)
- Out 3 is not used

I/O matrix

- 4 images to be taken (RGBW) result in 4 sequences
- RGB PWM change with different intensities (duty cycle) taking care for differences in spectral response of the camera sensor
- PWM change 0-2 is connected to out 0-2
- Seq pulse A is driving the exposure (trigger)
- Seq pulse B is driving the strobe
- Seq pulse B in WHITE sequence is reduced down to 33% as light intensities of 3 lights (RGB) will add up

Notes

- Different exposure / strobe timings are used for illustration. In most cases they will show values same as exposure
- The resulting exposure time shows the period of sensor light exposure. ("masking" of exposure time by creating strobe light impulses shorter than exposure time). This value is not adjustable at the camera
- PWM change is shown with reduced height for demonstrating reduced intensity. In reality though, PWM change will be full height (full voltage, shunt resistor might be necessary) with the adjusted duty cycle
- Use a PWM frequency high enough not to interfere with your timings (here: 1000 Hz)

Scenario values	Interval 0 (RED)	Interval 1 (GREEN)	Interval 2 (BLUE)	Interval 3 (WHITE)
Sequencer Interval	1000 ms	1000 ms	1000 ms	1000 ms
Seq pulse A start	0 ms	0 ms	100 ms	0 ms
Seq pulse A stop	100 ms	300 ms	300 ms	100 ms
Seq pulse B start	0 ms	100 ms	200 ms	0 ms
Seq pulse B stop	100 ms	200 ms	300 ms	33 ms
PWM Frequency f	1000 Hz	1000 Hz	1000 Hz	1000 Hz
PWM change 0 (RED)	100%	0%	0%	100%
PWM change 1 (GREEN)	0%	70%	0%	70%
PWM change 2 (BLUE)	0%	0%	80%	80%
PWM change 3	-	-	-	-

As being said before, all these values have to be entered into the camera's GenICam tree as tic values.

The timing values translate like this into tics:

Values to set in GenICam properties	Interval 0 (RED)	Interval 1 (GREEN)	Interval 2 (BLUE)	Interval 3 (WHITE)
Sequencer Interval	6666667 tic (1000 ms)	6666667 tic (1000 ms)	6666667 tic (1000 ms)	6666667 tic (1000 ms)
Seq pulse A start	0 tic (0 ms)	0 tic (0 ms)	6666667 tic (100 ms)	0 tic (0 ms)
Seq pulse A stop	6666667 tic (100 ms)	20000000 tic (300 ms)	20000000 tic (300 ms)	6666667 tic (100 ms)
Seq pulse B start	0 tic (0 ms)	6666667 tic (100 ms)	13333333 tic (200 ms)	0 tic (0 ms)
Seq pulse B stop	6666667 tic (100 ms)	13333333 tic (200 ms)	20000000 tic (300 ms)	2200000 tic (33 ms)
Effective exposure time	100 ms	100 ms	100 ms	33 ms
PWM Frequency f	66667 tic (1000 Hz)	66667 tic (1000 Hz)	66667 tic (1000 Hz)	66667 tic (1000 Hz)
PWM change 0 (RED)	66667 tic (100% of 1000 Hz)	0 tic	0 tic	66667 tic (100% of 1000 Hz)
PWM change 1 (GREEN)	0 tic	46667 tic (70% of 1000 Hz)	0 tic	46667 tic (70% of 1000 Hz)
PWM change 2 (BLUE)	0 tic	0 tic	53333 tic (80% of 1000 Hz)	53333 tic (80% of 1000 Hz)
PWM change 3	-	-	-	-

In a timings diagram, the sequence values above will look like this

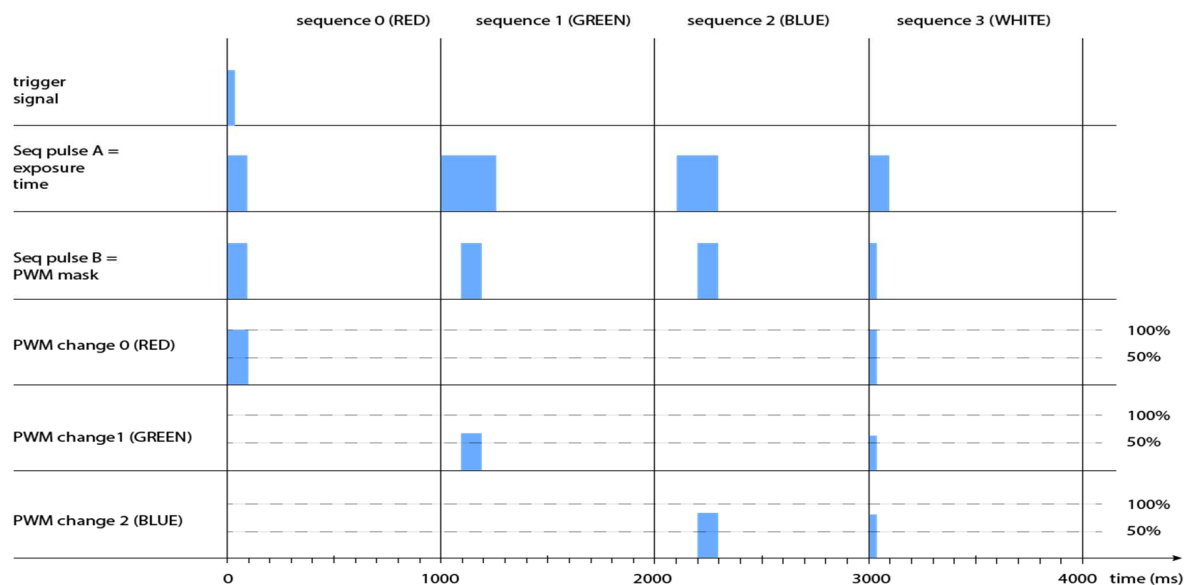

Sequencer setup with SVCapture

Starting with SVCapture 2.5.2, there is a sequencer assistant, providing easy setup of the sequencer settings. The assistant will help you to setup timings for start exposure and lighting and so on. The PWMs are connected to the physical outputs (e.g. for driving LED lights)..

For making the sequencer work in general, have a look into the GenICam tree or even more simple into the I/O assistant. Connect the the I/O lines as below:

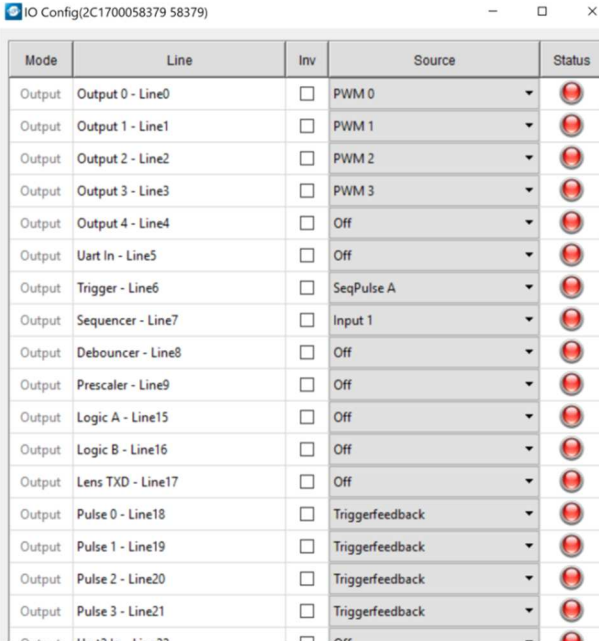

IO Config(2C1700058379 58379)

Mode	Line	Inv	Source	Status
Output	Output 0 - Line0	<input type="checkbox"/>	PWM 0	
Output	Output 1 - Line1	<input type="checkbox"/>	PWM 1	
Output	Output 2 - Line2	<input type="checkbox"/>	PWM 2	
Output	Output 3 - Line3	<input type="checkbox"/>	PWM 3	
Output	Output 4 - Line4	<input type="checkbox"/>	Off	
Output	Uart In - Line5	<input type="checkbox"/>	Off	
Output	Trigger - Line6	<input type="checkbox"/>	SeqPulse A	
Output	Sequencer - Line7	<input type="checkbox"/>	Input 1	
Output	Debouncer - Line8	<input type="checkbox"/>	Off	
Output	Prescaler - Line9	<input type="checkbox"/>	Off	
Output	Logic A - Line15	<input type="checkbox"/>	Off	
Output	Logic B - Line16	<input type="checkbox"/>	Off	
Output	Lens TXD - Line17	<input type="checkbox"/>	Off	
Output	Pulse 0 - Line18	<input type="checkbox"/>	Triggerfeedback	
Output	Pulse 1 - Line19	<input type="checkbox"/>	Triggerfeedback	
Output	Pulse 2 - Line20	<input type="checkbox"/>	Triggerfeedback	
Output	Pulse 3 - Line21	<input type="checkbox"/>	Triggerfeedback	

You may start the sequence with a hardware trigger input signal (sequencer is connected to Input 1). As an alternative you might use a software trigger. For software trigger setup, adjust as below:

Feature Name	Feature Value
Acquisition Control - Acquisition Mode	Continuous
Acquisition Control – Trigger Selector - Trigger Mode	On
Acquisition Control – Trigger Selector - Trigger Source	Line 1
Acquisition Control – Trigger Selector – Exposure Mode	Trigger Width
Enhanced IO – PWMEnable	On
Enhanced IO – SeqEnable	On

The Exposure mode „trigger width“ makes exposure start at a certain timing (Seq pulse A) and stop at Seq pulse B. In the GenICam tree this

will reflect as following:

Property	Value
> Device Control	
> Image Format Control	
> Acquisition Control	
Acquisition Mode	Continuous
> Trigger Selector	Acquisition Start
Trigger Mode	On
Generate Software Trigger	(command)
Trigger Source	Line 1
Trigger Activation	Rising Edge
Trigger Delay	0 us
Exposure Mode	Trigger Width
Acquisition Frame Rate	10 Hz
Exposure Time	99871 us
Exposure Auto	Off
Exposure First	<input type="checkbox"/> Off
ExposureTimeMin	1000 us
ExposureTimeMax	300000 us
Sensor Shutter Mode	Global Shutter
> Strobe Control	
> Enhanced IO	
PWMEnable	<input checked="" type="checkbox"/> On
SeqTrigger	(command)
SeqTriggermode	Trigger on high level
> SeqSelector	3
SeqInterval	6700000
SeqPulseAStart	0
SeqPulseAStop	6666666
SeqPulseBStart	0
SeqPulseBStop	6666666
PWMMax	66666
PWMChange0	0
PWMChange1	0
PWMChange2	0
PWMChange3	66666
SeqCount	4
SeqEnable	<input checked="" type="checkbox"/> On
SeqLoop	<input type="checkbox"/> Off
DebounceDuration	66666
PrescaleDivisor	2
> LUT Control	

5.3.7 Optical Input

In many trigger signals you find noise, transients and voltage spikes. These are able to damage components in the camera and trigger signal interpretation might be difficult.

An optical input separates the electrical trigger and camera circuits. The benefit of such an optical input is to avoid all these kinds of interaction from power sources or switches. The disadvantage of an optical input is that it is slower in terms of signal transmission and slew rate than a direct electrical connection.

If you need super fast response from the camera, direct electrical access is your choice. If your camera trigger is in the ms range or slower, we recommend to use the optical input.

An optical input needs some current for operation. The SVS-Vistek optical input is specified to 5-24V, 8mA.

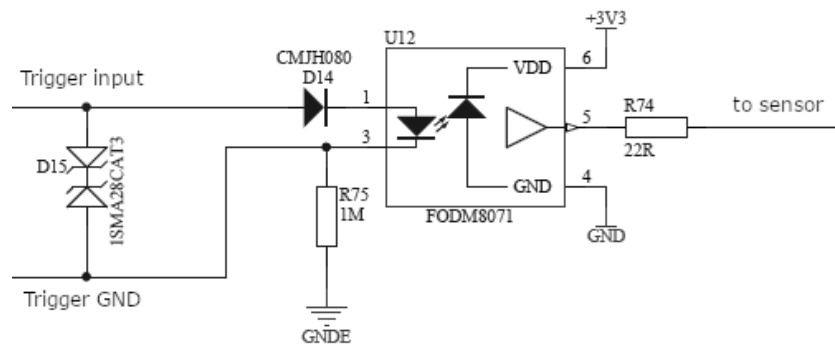

The opto coupler galvanically separates electrical circuits by emitting light on one side and interpreting light in the other. There is no direct electric interaction between both electrical circuits.

5.3.8 PLC/Logical Operation on Inputs

The logic input combines trigger signals with Boolean algorithms. The camera provides AND, NAND, OR, NOR as below. You might combine true/false states of the inputs to determine camera actions. The result can be connected to a camera trigger signal or it may be source for the next logical operation with another input. It is possible to connect it to an OUT line as well.

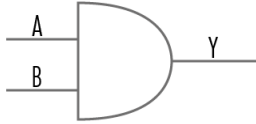

AND

Both trigger inputs have to be true.

A	B	$Y = A \wedge B$
0	0	0
0	1	0
1	0	0
1	1	1

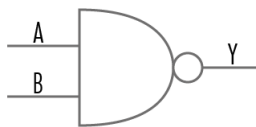

NAND

The **NEGATIVE-AND** is true only if its inputs are false.

Invert the output of the AND module.

A	B	$Y = A \text{ NAND } B$
0	0	1
0	1	1
1	0	1
1	1	0



OR

If neither input is high, a low pulse_out (0) results.

Combine trigger input one and two.

A	B	$Y = A \vee B$
0	0	0
0	1	1
1	0	1
1	1	1



NOR

No trigger input – one nor two – results in a high or a low level pulse_out.

Invert both trigger inputs. By inverting the resulting pulse_out you will get the NOR I pulse

A	B	$Y = A \bar{\vee} B$	NOR	$Y = A \vee B$	NOR i
0	0	1		0	
0	1	0		1	
1	0	0		1	
1	1	0		1	

5.3.9 Serial data interfaces

(ANSI EIA/) TIA-232-F

RS-232 and RS-422 (from EIA, read as Radio Sector or commonly as Recommended Standard) are technical standards to specify electrical characteristics of digital signalling circuits. Serial connection might be used to control SVCams. These signals are used to send low-power data signals to control exposure, light or lenses (MFT). Usage scenario is a control possibility without network. Be aware of low connection speed.

serial interface parameters – RS-232 and RS-422

Serial interface Parameter	RS-232	RS-422
Maximum open-circuit voltage	±25 V	±6 V
Max Differential Voltage	25 V	10 V
Min. Signal Range	±3 V	2 V
Max. Signal Range	±15V	10 V

See your camera [data sheet](#) regarding its serial capabilities.

Data transport is always asynchronous. Synchronization is implemented by first and last bit of a package. Datarate (bits per second) must be defined before transmission.

RS232

RS232 is splitted into 2 lines receiving and transferring Data.

RXD receive data
TXD transmit data

Signal voltage values are:

low: -3 ... -15 V
high: +3 ... +15 V

With restrictions: refer to table of serial interface parameter above.

Packaging Data into containers (adding start and stop bits) is implemented by the UART (Universal Asynchronous Receiver Transmitter)

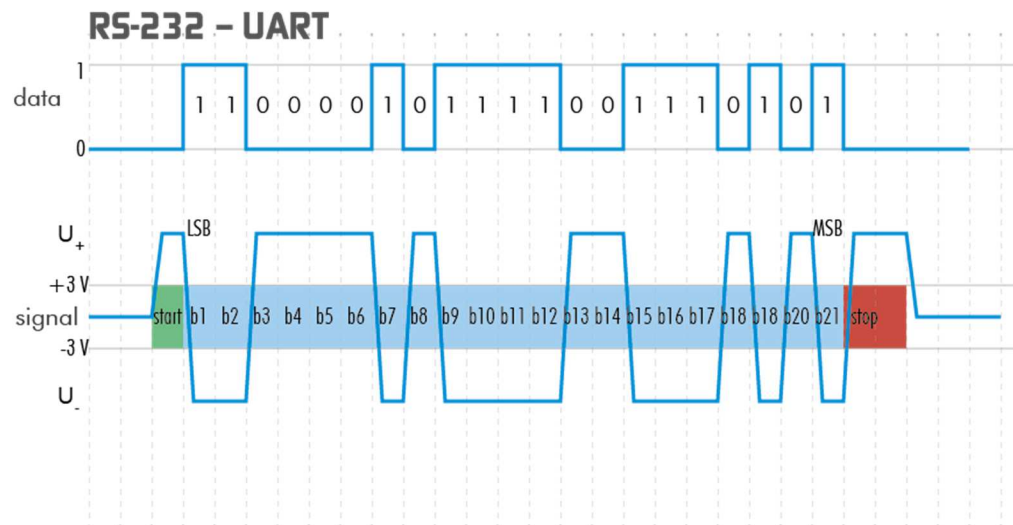

UART encoding of a data stream

5.3.10 Trigger-Edge Sensitivity

Trigger-Edge Sensitivity is implemented by a “schmitt trigger”. Instead of triggering to a certain value Schmitt trigger provides a threshold.

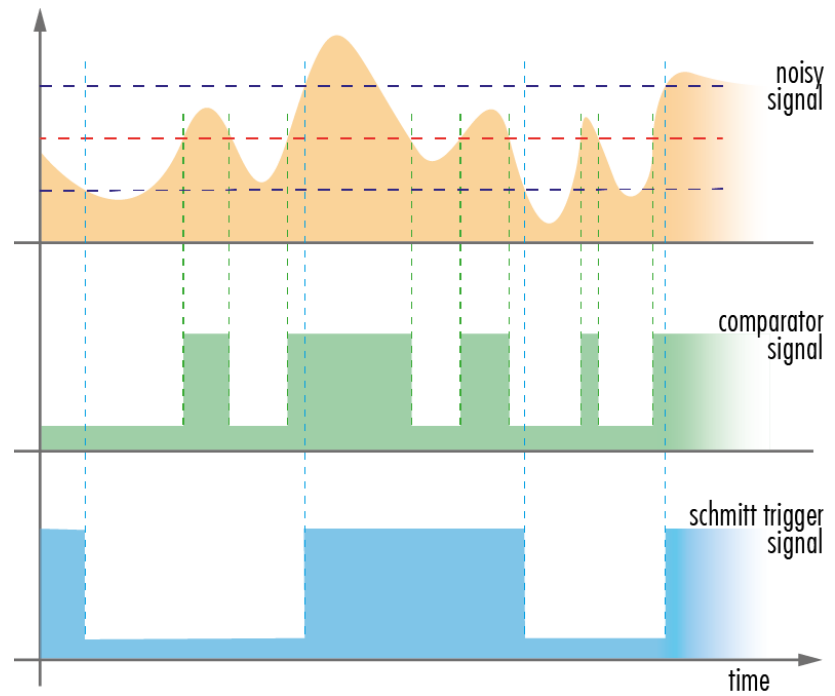

Schmitt trigger noise suppression

5.3.11 Debouncing Trigger Signals

Bounces or glitches caused by a switch can be avoided by software within the SVCam.

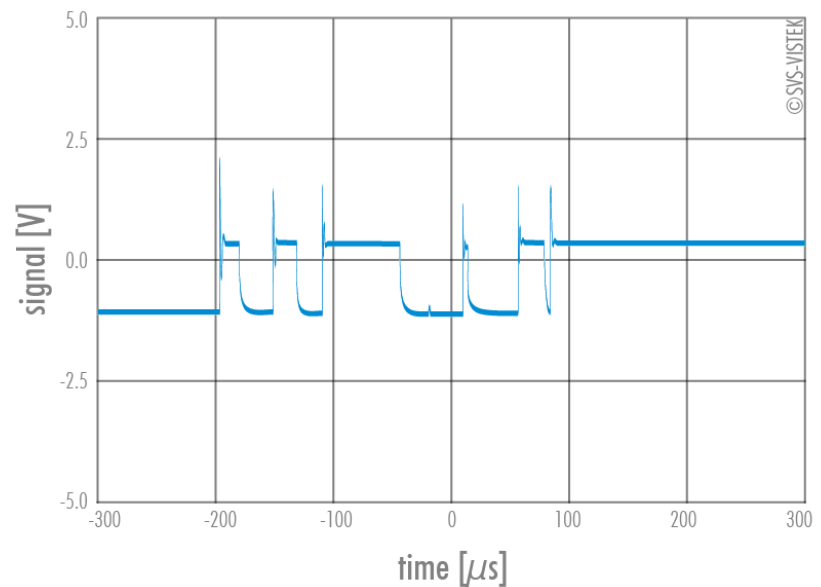

bounces or glitches caused by a switch

Therefore the signal will not be accepted till it lasts at least a certain time.

Use the IO Assignment tool to place and enable the debouncer module in between the "trigger" (schmitt trigger) and the input source (e.g.: line 1).

DebounceDuration register can be set in multiples of 15ns (implement of system clock). E.g. 66 666 \approx 1 ms

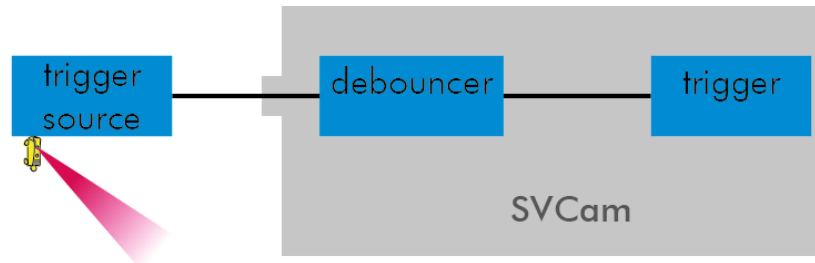

debouncer between the trigger source and trigger

The Debouncer module

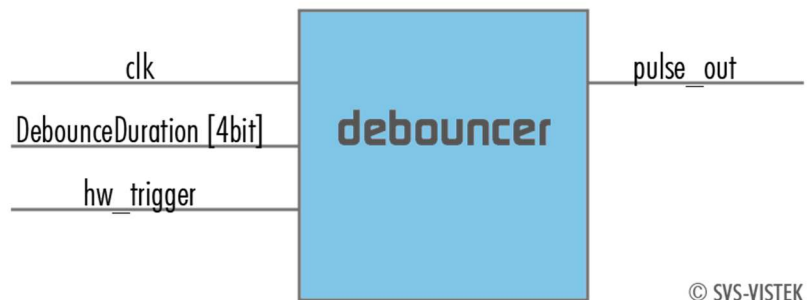

the debouncer module

5.3.12 Prescale

The Prescaler function can be used for masking off input pulses by applying a divisor with a 4-bit word, resulting in 16 unique settings.

- > Reducing count of interpreted trigger signal
- > Use the prescaler to ignore a certain count of trigger signals.
- > Divide the amount of trigger signals by setting a divisor.
- > Maximum value for prescale divisor: is 16 (4 bit)

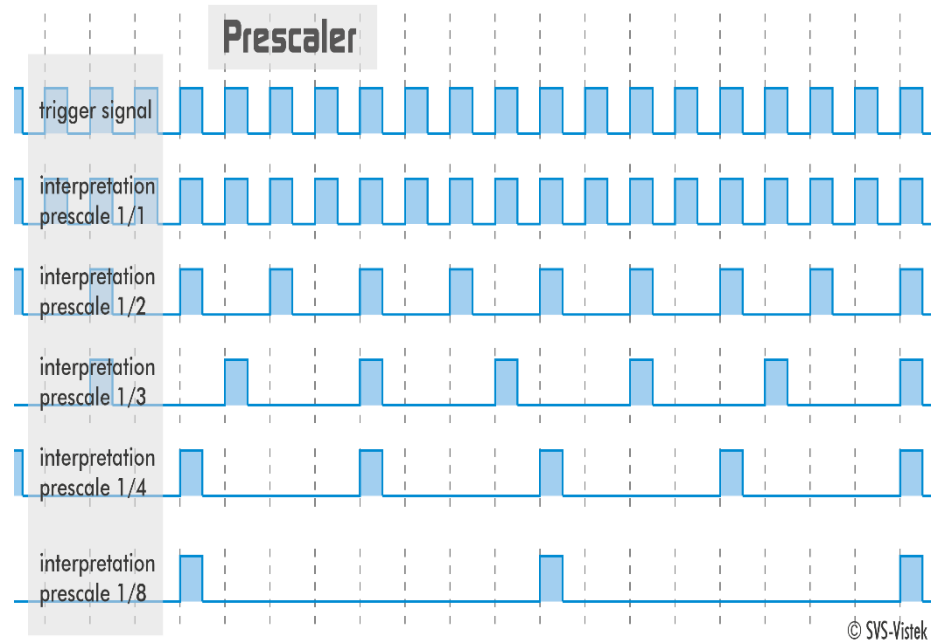

Prescale values and their result on trigger signal

The prescale module

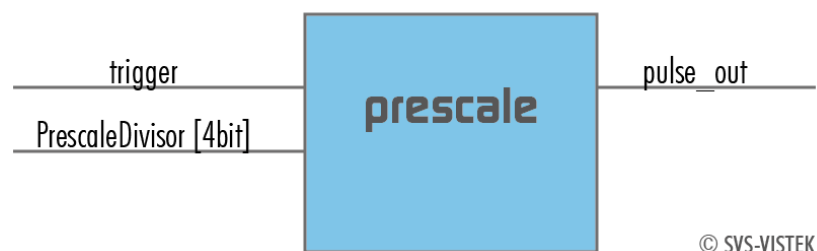

the prescale module

6 Specifications

All specifications can be viewed as well on our website, www.svs-vistek.com. We are proud to have ongoing development on our cameras, so specs might change and new features being added. Spectral response curves are sensor only and do not include camera spectral response modifications due to filters or cover glass.

The following pages will give an overview of the core features of EXO Camera Link cameras.

Note: The EXO*CL cameras are supporting 1x3_1y tap configuration. If your framegrabber is supporting this as well, you might get framerates up to 50% higher than shown in the datasheet.

6.1 exo174*CL

Model	exo174MCL	exo174CCL
family	EXO	EXO
active pixel w x h	1920 x 1200	1920 x 1200
max. frame rate	105 fps	105 fps
chroma	mono	color
interface	Camera Link Base	Camera Link Base
sensor name	IMX174LLJ	IMX174LQJ
sensor manufacturer	Sony	Sony
sensor architecture	Area CMOS	Area CMOS
shutter type	global	global
equivalent format	1/1.2"	1/1.2"
diagonal	13.4 mm	13.4 mm
pixel w x h	5.86x5.86 μm	5.86x5.86 μm
optic sensor w x h	11.34x7.13 mm	11.34x7.13 mm
exposure time	20 μs / 1s	20 μs / 1s
max. gain	18 dB	18 dB
dynamic range	72 dB environment dependant	72 dB environment dependant
S/N Ratio	44 dB environment dependant	44 dB environment dependant
frame buffer	256MB RAM 32MB Flash	256MB RAM 32MB Flash
CL geometry	1x2-1y;1x3-1y	1x2-1y;1x3-1y
frequency select	-	-
exp. time adjustment	manual;auto;external	manual;auto;external
px format 8 / 12 / 16	x / x / -	x / x / -
packed readout	-	-
max binning h / v	2 / 2	2 / 2
LUT	12to8(1)	12to8(1)
ROI	1	1
white balancing	-	auto;manual
tap balancing	-	-
gain	auto;manual	auto;manual
black level	manual	manual
PIV	-	-
readout control	-	-
flat field correction	-	-
shading correction	-	-
defect pixel correction	-	-
image flip	horizontal;vertical	horizontal;vertical
trigger int / ext / soft	x / x / x	x / x / x
trigger edge high / low sequencer	x / x	x / x

PWM power out	x	x
trigger IN TTL-24 V	2	2
outputs open drain	4	4
optical in / out	1 / -	1 / -
RS-232 in / out	1 / 1	1 / 1
RS-422 in / out	- / -	- / -
power supply	10...25 V	10...25 V

lens mount	C-Mount	C-Mount
dynamic lens control	-	-
size w / h / d (1)	50x50x33.89 mm	50x50x33.89 mm
weight	138 g	138 g
protection class	IP40	IP40
power consumption	4.0 W	4.0 W
operating temperature	-10...60°C	-10...60°C
humidity non-condensing	10...90 %	10...90 %
status	production	production

(1) please refer to drawings

Spectral sensitivity characteristics

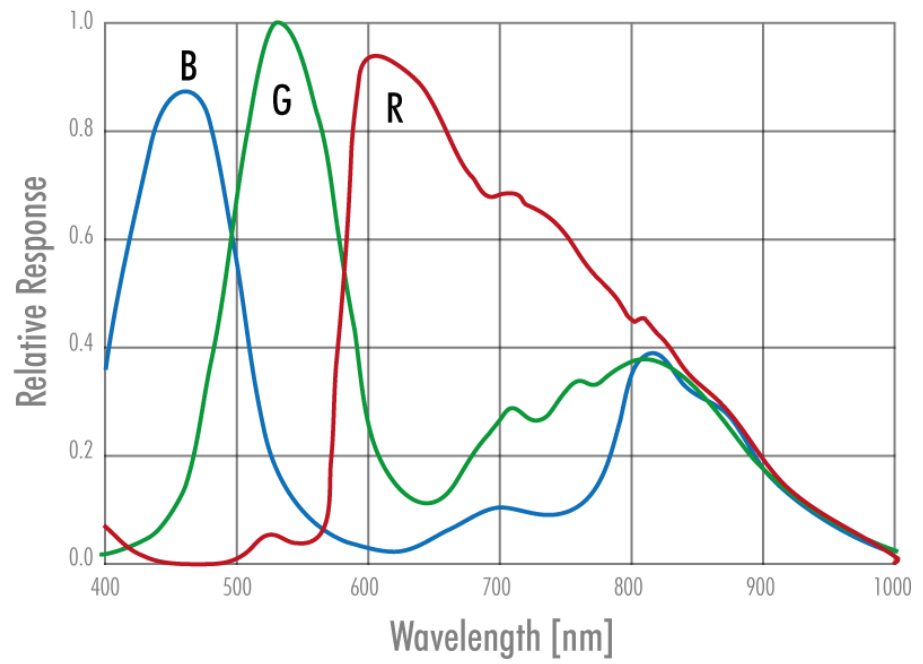
Color

IMX174LQJ

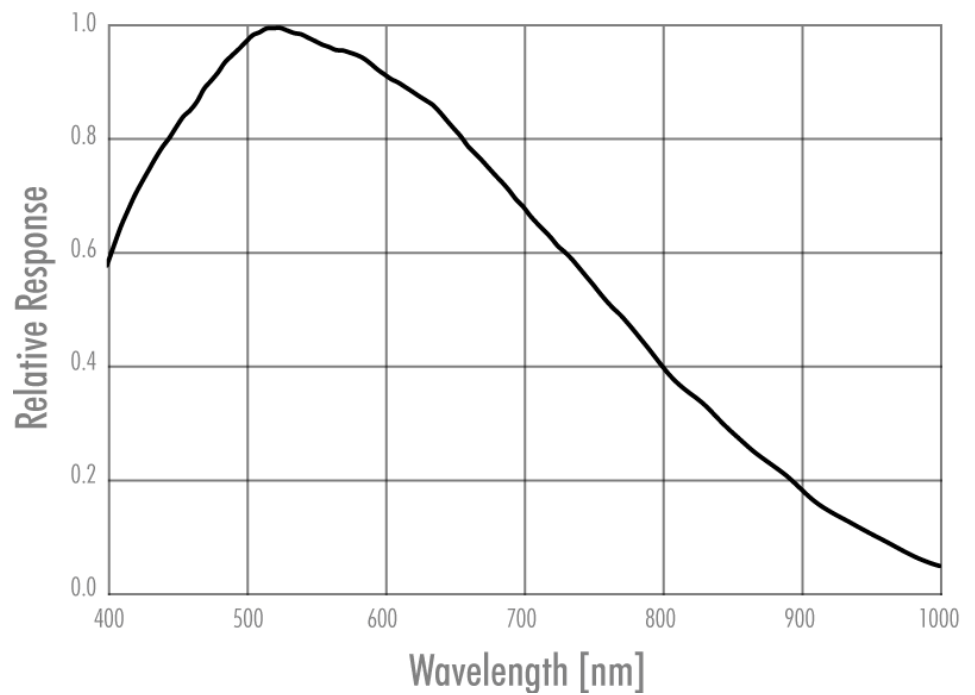
Mono

IMX174LLJ

6.2 exo183*CL

Model	exo183MCL	exo183CCL
family	EXO	EXO
active pixel w x h	5488 x 3672	5488 x 3672
max. frame rate	12 fps	12 fps
chroma	mono	color
interface	Camera Link Base	Camera Link Base
sensor name	IMX183CLK	IMX183CQJ
sensor manufacturer	Sony	Sony
sensor architecture	Area CMOS	Area CMOS
shutter type	rolling	rolling
equivalent format	1"	1"
diagonal	15.9 mm	15.9 mm
pixel w x h	2.4x2.4 μm	2.4x2.4 μm
optic sensor w x h	16.05x12.61 mm	16.05x12.61 mm
exposure time	228 μs / 1s	228 μs / 1s
max. gain	18 dB	18 dB
dynamic range	72 dB environment dependant	72 dB environment dependant
S/N Ratio	40 dB environment dependant	40 dB environment dependant
frame buffer	256MB RAM 32MB Flash	256MB RAM 32MB Flash
CL geometry	1x2-1y;1x3-1y	1x2-1y;1x3-1y
frequency select	-	-
exp. time adjustment	manual;auto	manual;auto
px format 8 / 12 / 16	x / x / -	x / x / -
packed readout	-	-
max binning h / v	2 / 2	2 / 2
LUT	12to8(1)	12to8(1)
ROI	1	1
white balancing	auto;manual	auto;manual
tap balancing	-	-
gain	auto;manual	auto;manual
black level	manual	manual
PIV	-	-
readout control	-	-
flat field correction	-	-
shading correction	-	-
defect pixel correction	-	-
image flip	-	-
trigger int / ext / soft	x / x / x	x / x / x
trigger edge high / low	x / x	x / x
sequencer	x	x
PWM power out	x	x
trigger IN TTL-24 V	2	2

outputs open drain	4	4
optical in / out	1 / -	1 / -
RS-232 in / out	1 / 1	1 / 1
RS-422 in / out	- / -	- / -
power supply	10...25 V	10...25 V

lens mount	C-Mount	C-Mount
dynamic lens control	-	-
size w / h / d (1)	50x50x33.89 mm	50x50x33.89 mm
weight	138 g	138 g
protection class	IP40	IP40
power consumption	4.0 W	4.0 W
operating temperature	-10...60°C	-10...60°C
humidity non-condensing	10...90 %	10...90 %
status	production	production

(1) please refer to drawings

Spectral sensitivity characteristics

Color

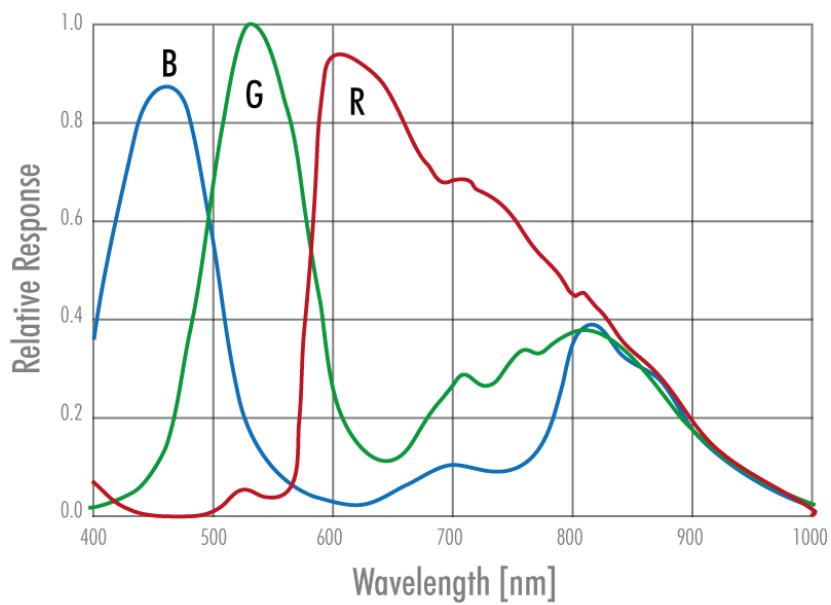

IMX183LQJ

Mono

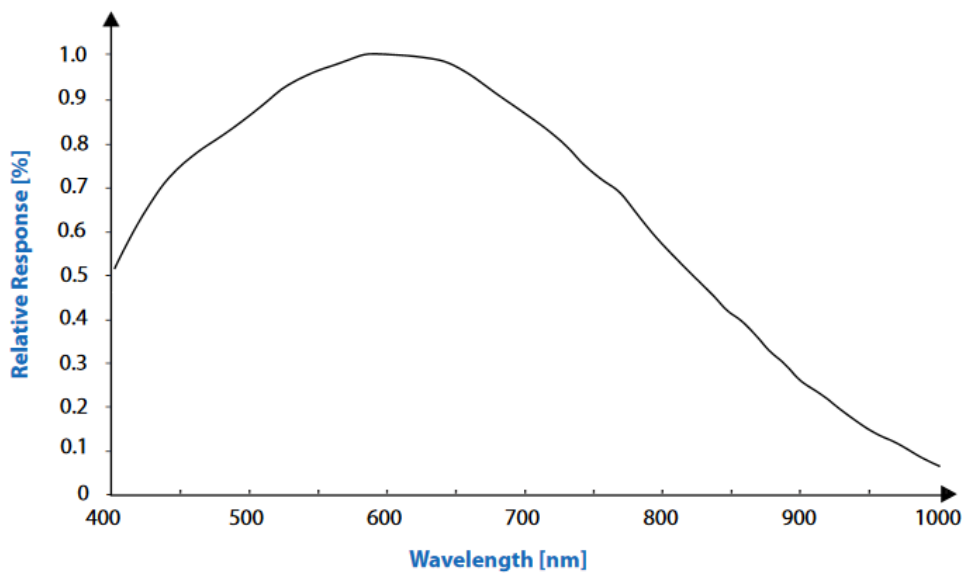

IMX183LLR

6.3 exo249*CL

Model	exo249CCL	exo249MCL
family	EXO	EXO
active pixel w x h	1920 x 1200	1920 x 1200
max. frame rate	31 fps	31 fps
chroma	color	mono
interface	Camera Link Base	Camera Link Base
sensor name	IMX249LQJ	IMX249LLJ
sensor manufacturer	Sony	Sony
sensor architecture	Area CMOS	Area CMOS
shutter type	global	global
equivalent format	1/1.2"	1/1.2"
diagonal	13.4 mm	13.4 mm
pixel w x h	5.86x5.86 μm	5.86x5.86 μm
optic sensor w x h	11.34x7.13 mm	11.34x7.13 mm
exposure time	38 μs / 1s	38 μs / 1s
max. gain	18 dB	18 dB
dynamic range	72 dB environment dependant	72 dB environment dependant
S/N Ratio	44 dB environment dependant	44 dB environment dependant
frame buffer	256MB RAM 32MB Flash	256MB RAM 32MB Flash
CL geometry	1x2-1y;1x3-1y	1x2-1y;1x3-1y
frequency select	-	-
exp. time adjustment	manual;auto;external	manual;auto;external
px format 8 / 12 / 16	x / x / -	x / x / -
packed readout	-	-
max binning h / v	2 / 2	2 / 2
LUT	12to8(1)	12to8(1)
ROI	1	1
white balancing	-	auto;manual
tap balancing	-	-
gain	auto;manual	auto;manual
black level	manual	manual
PIV	-	-
readout control	-	-
flat field correction	-	-
shading correction	-	-
defect pixel correction	-	-
image flip	horizontal;vertical	horizontal;vertical
trigger int / ext / soft	x / x / x	x / x / x
trigger edge high / low	x / x	x / x
sequencer	x	x
PWM power out	x	x
trigger IN TTL-24 V	2	2

outputs open drain	4	4
optical in / out	1 / -	1 / -
RS-232 in / out	1 / 1	1 / 1
RS-422 in / out	- / -	- / -
power supply	10...25 V	10...25 V

lens mount	C-Mount	C-Mount
dynamic lens control	-	-
size w / h / d (1)	50x50x33.89 mm	50x50x33.89 mm
weight	138 g	138 g
protection class	IP40	IP40
power consumption	4.0 W	4.0 W
ambient temperature	-10...45°C	-10...45°C
humidity non-condensing	10...90 %	10...90 %
status	replaced	replaced

(1) please refer to drawings

Spectral sensitivity characteristics

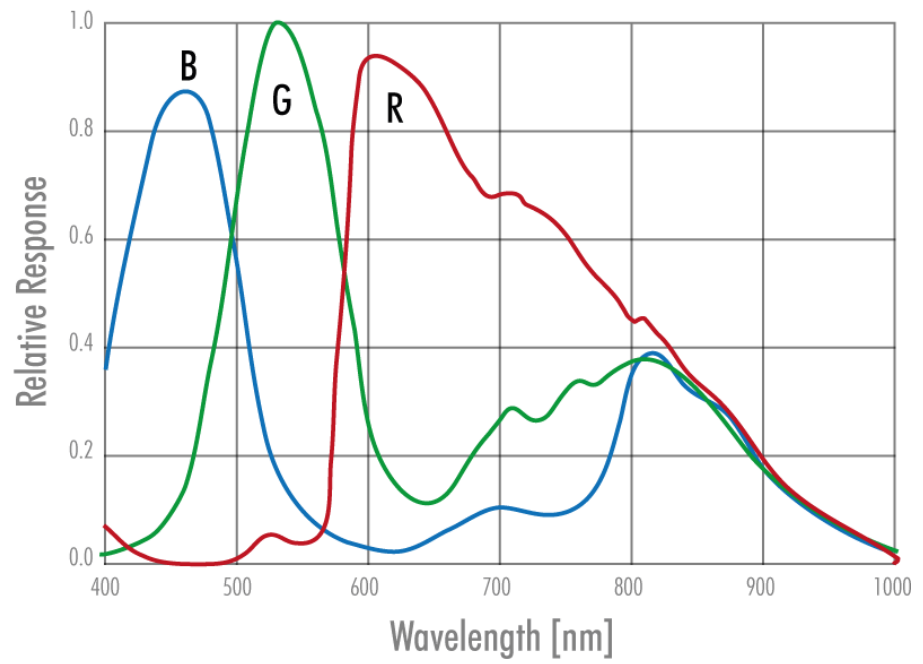
Color

IMX249LQJ

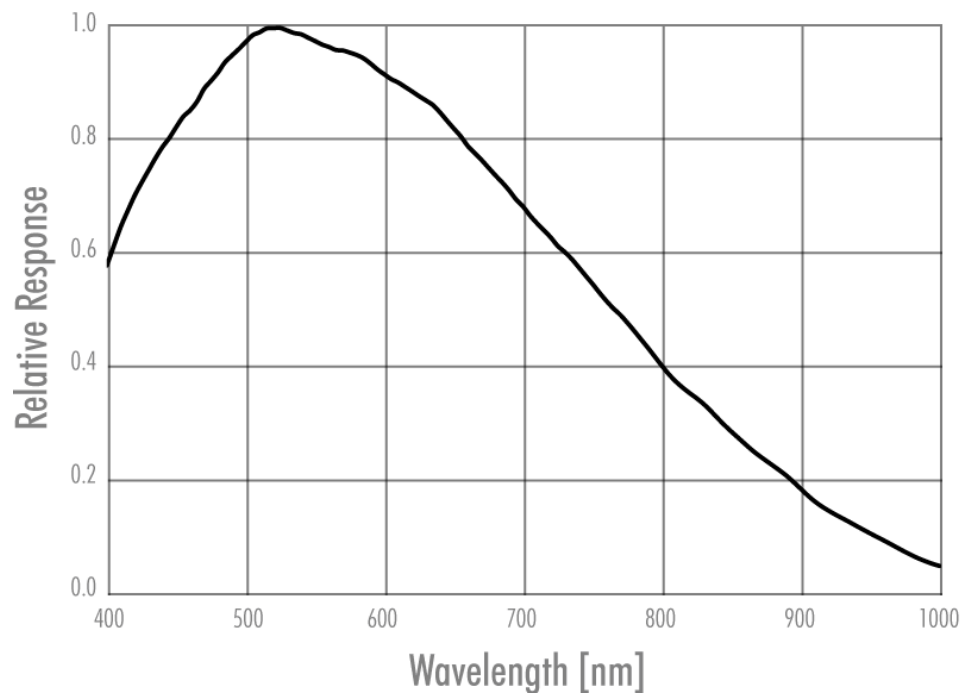
Mono

IMX249LLJ

6.4 exo250*CL

Model	exo250MCL	exo250CCL
family	EXO	EXO
active pixel w x h	2448 x 2048	2448 x 2048
max. frame rate	49 fps	49 fps
chroma	mono	color
interface	Camera Link Base	Camera Link Base
sensor name	IMX250LLR	IMX250LQR
sensor manufacturer	Sony	Sony
sensor architecture	Area CMOS	Area CMOS
shutter type	global	global
equivalent format	2/3"	2/3"
diagonal	11.1 mm	11.1 mm
pixel w x h	3.45x3.45 μ m	3.45x3.45 μ m
optic sensor w x h	8.5x7.09 mm	8.5x7.09 mm
exposure time	20 μ s / 1s	20 μ s / 1s
max. gain	18 dB	18 dB
dynamic range	72 dB environment dependant	72 dB environment dependant
S/N Ratio	40 dB environment dependant	40 dB environment dependant
frame buffer	256MB RAM 32MB Flash	256MB RAM 32MB Flash
CL geometry	1x2-1y;1x3-1y	1x2-1y;1x3-1y
frequency select	-	-
exp. time adjustment	manual;auto;external	manual;auto;external
px format 8 / 12 / 16	x / x / -	x / x / -
packed readout	-	-
max binning h / v	2 / 2	2 / 2
LUT	12to8(1)	12to8(1)
ROI	1	1
white balancing	-	auto;manual
tap balancing	-	-
gain	auto;manual	auto;manual
black level	manual	manual
PIV	-	-
readout control	-	-
flat field correction	-	-
shading correction	-	-
defect pixel correction	-	-
image flip	horizontal;vertical	horizontal;vertical
trigger int / ext / soft	x / x / x	x / x / x
trigger edge high / low sequencer	x / x	x / x

PWM power out	x	x
trigger IN TTL-24 V	2	2
outputs open drain	4	4
optical in / out	1 / -	1 / -
RS-232 in / out	1 / 1	1 / 1
RS-422 in / out	- / -	- / -
power supply	10...25 V	10...25 V

lens mount	C-Mount	C-Mount
dynamic lens control	-	-
size w / h / d (1)	50x50x34.12 mm	50x50x34.12 mm
weight	138 g	138 g
protection class	IP40	IP40
power consumption	4.0 W	4.0 W
operating temperature	-10...60°C	-10...60°C
humidity non-condensing	10...90 %	10...90 %
status	production	production

(1) please refer to drawings

Spectral sensitivity characteristics

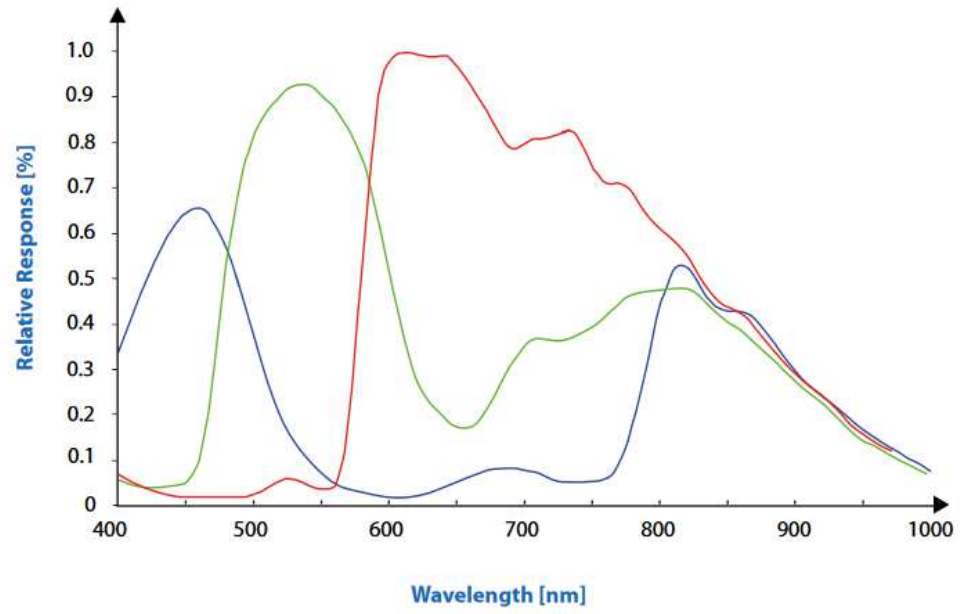
Color

IMX250LQJR

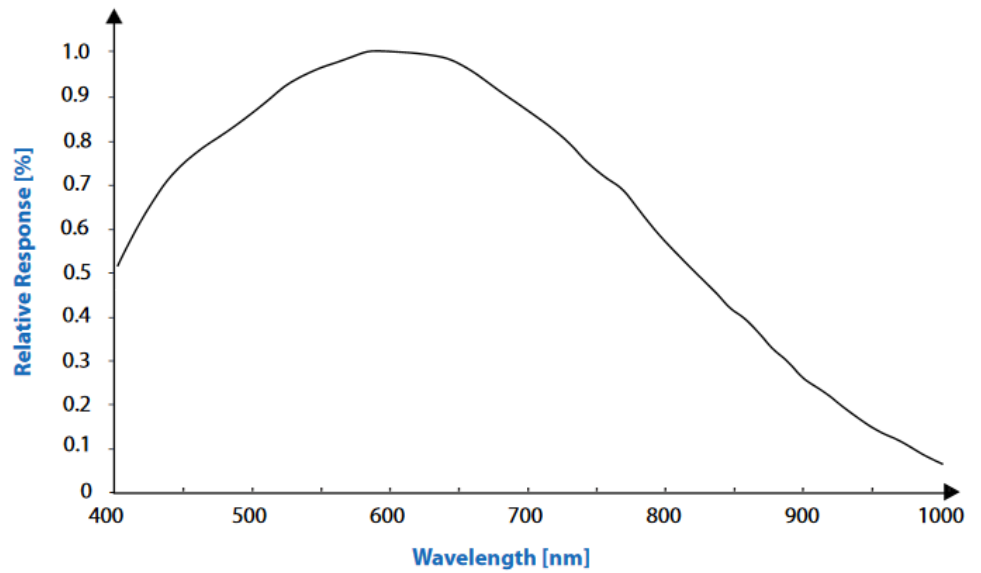
Mono

IMX250LLR

6.5 exo252*CL

Model	exo252MCL	exo252CCL
family	EXO	EXO
active pixel w x h	2048 x 1536	2048 x 1536
max. frame rate	78 fps	78 fps
chroma	mono	color
interface	Camera Link Base	Camera Link Base
sensor name	IMX252LLR	IMX252LQR
sensor manufacturer	Sony	Sony
sensor architecture	Area CMOS	Area CMOS
shutter type	global	global
equivalent format	1/1.8"	1/1.8"
diagonal	8.9 mm	8.9 mm
pixel w x h	3.45x3.45 μ m	3.45x3.45 μ m
optic sensor w x h	8.5x7.09 mm	8.5x7.09 mm
exposure time	20 μ s / 1s	20 μ s / 1s
max. gain	18 dB	18 dB
dynamic range	71 dB environment dependant	71 dB environment dependant
S/N Ratio	40 dB environment dependant	40 dB environment dependant
frame buffer	256MB RAM 32MB Flash	256MB RAM 32MB Flash
CL geometry	1x2-1y;1x3-1y	1x2-1y;1x3-1y
frequency select	-	-
exp. time adjustment	manual;auto;external	manual;auto;external
px format 8 / 12 / 16	x / x / -	x / x / -
packed readout	-	-
max binning h / v	2 / 2	2 / 2
LUT	12to8(1)	12to8(1)
ROI	1	1
white balancing	-	auto;manual
tap balancing	-	-
gain	auto;manual	auto;manual
black level	manual	manual
PIV	-	-
readout control	-	-
flat field correction	-	-
shading correction	-	-
defect pixel correction	-	-
image flip	horizontal;vertical	horizontal;vertical
trigger int / ext / soft	x / x / x	x / x / x
trigger edge high / low sequencer	x / x	x / x

PWM power out	x	x
trigger IN TTL-24 V	2	2
outputs open drain	4	4
optical in / out	1 / -	1 / -
RS-232 in / out	1 / 1	1 / 1
RS-422 in / out	- / -	- / -
power supply	10...25 V	10...25 V

lens mount	C-Mount	C-Mount
dynamic lens control	-	-
size w / h / d (1)	50x50x34.12 mm	50x50x34.12 mm
weight	138 g	138 g
protection class	IP40	IP40
power consumption	4.0 W	4.0 W
operating temperature	-10...60°C	-10...60°C
humidity non-condensing	10...90 %	10...90 %
status	production	production

(1) please refer to drawings

Spectral sensitivity characteristics

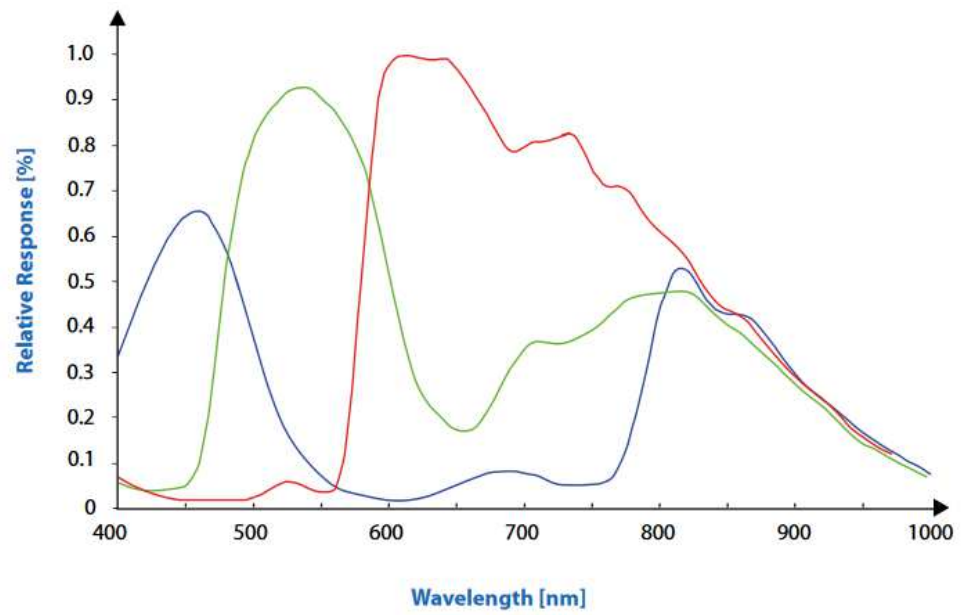
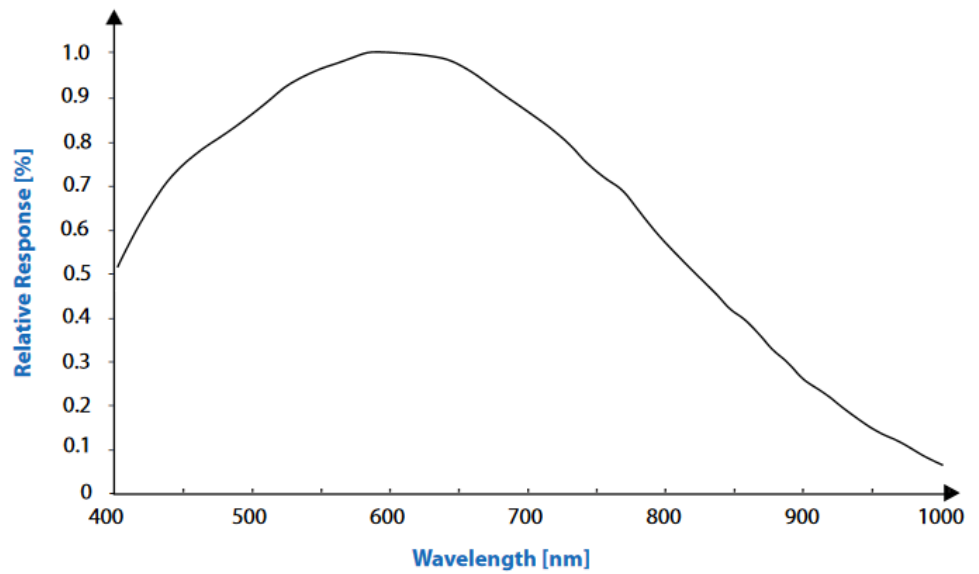
Color*Mono*

6.6 exo267*CL

Model	exo267MCL	exo267CCL
family	EXO	EXO
active pixel w x h	4096 x 2160	4096 x 2160
max. frame rate	28 fps	28 fps
chroma	mono	color
interface	Camera Link Base	Camera Link Base
sensor name	IMX267LLR	IMX267LQR
sensor manufacturer	Sony	Sony
sensor architecture	Area CMOS	Area CMOS
shutter type	global	global
equivalent format	1"	1"
diagonal	16.0 mm	16.0 mm
pixel w x h	3.45x3.45 μm	3.45x3.45 μm
optic sensor w x h	8.5x7.09 mm	8.5x7.09 mm
exposure time	29 μs / 1s	29 μs / 1s
max. gain	18 dB	18 dB
dynamic range	72 dB environment dependant	72 dB environment dependant
S/N Ratio	39 dB environment dependant	39 dB environment dependant
frame buffer	256MB RAM 32MB Flash	256MB RAM 32MB Flash
CL geometry	1x2-1y;1x3-1y	1x2-1y;1x3-1y
frequency select	-	-
exp. time adjustment	manual;auto;external	manual;auto;external
px format 8 / 12 / 16	x / x / -	x / x / -
packed readout	-	-
max binning h / v	2 / 2	2 / 2
LUT	12to12(1)	12to12(1)
ROI	-	-
white balancing	-	-
tap balancing	-	-
gain	auto;manual	auto;manual
black level	manual	manual
PIV	-	-
readout control	-	-
flat field correction	x	x
shading correction	external	external
defect pixel correction	x	x
image flip	horizontal;vertical	horizontal;vertical
trigger int / ext / soft	x / x / x	x / x / x
trigger edge high / low sequencer	x / x	x / x
	x	x

PWM power out	x	x
trigger IN TTL-24 V	2	2
outputs open drain	4	4
optical in / out	1 / -	1 / -
RS-232 in / out	1 / 1	1 / 1
RS-422 in / out	- / -	- / -
power supply	10...25 V	10...25 V

lens mount	C-Mount	C-Mount
dynamic lens control	-	-
size w / h / d (1)	50x50x34.12 mm	50x50x34.12 mm
weight	140 g	140 g
protection class	IP40	IP40
power consumption	4.0 W	4.0 W
operating temperature	-10...60°C	-10...60°C
humidity non-condensing	10...90 %	10...90 %
status	production	production

(1) please refer to drawings

Spectral sensitivity characteristics

Color

Figure 3: IMX267LQR

Mono

Figure 4: IMX267LLR

6.7 exo304*CL

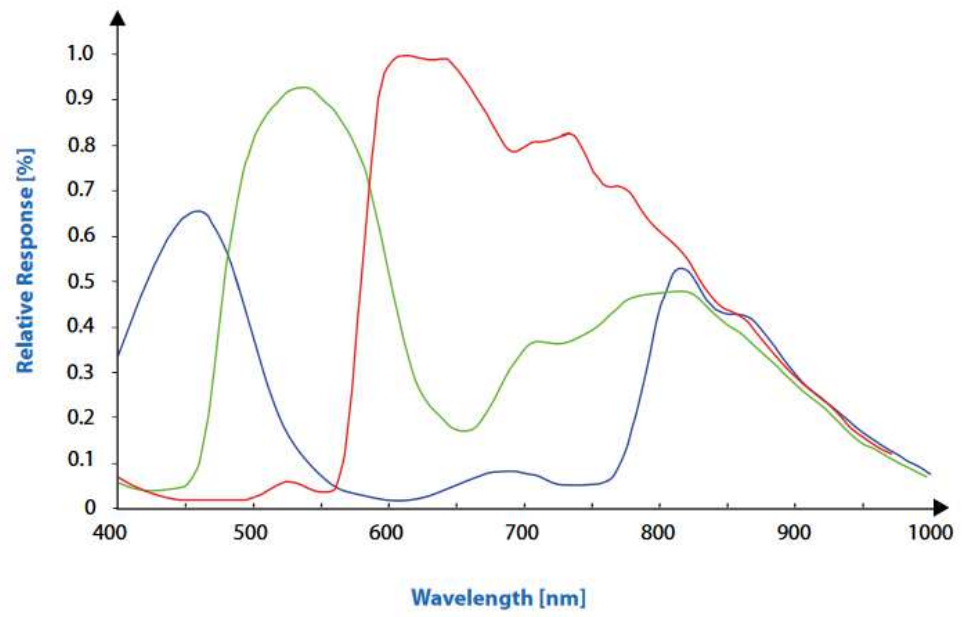
Model	exo304MCL	exo304CCL
family	EXO	EXO
active pixel w x h	4096 x 3000	4096 x 3000
max. frame rate	20 fps	20 fps
chroma	mono	color
interface	Camera Link Base	Camera Link Base
sensor name	IMX304LLR	IMX304LQR
sensor manufacturer	Sony	Sony
sensor architecture	Area CMOS	Area CMOS
shutter type	global	global
equivalent format	1.1"	1.1"
diagonal	17.6 mm	17.6 mm
pixel w x h	3.45x3.45 μ m	3.45x3.45 μ m
optic sensor w x h	8.5x7.09 mm	8.5x7.09 mm
exposure time	29 μ s / 1s	29 μ s / 1s
max. gain	18 dB	18 dB
dynamic range	72 dB environment dependant	72 dB environment dependant
S/N Ratio	40 dB environment dependant	40 dB environment dependant
frame buffer	256MB RAM 32MB Flash	256MB RAM 32MB Flash
CL geometry	1x2-1y;1x3-1y	1x2-1y;1x3-1y
frequency select	-	-
exp. time adjustment	manual;auto;external	manual;auto;external
px format 8 / 12 / 16	x / x / -	x / x / -
packed readout	-	-
max binning h / v	2 / 2	2 / 2
LUT	12to8(1)	12to8(1)
ROI	1	1
white balancing	-	auto;manual
tap balancing	-	-
gain	auto;manual	auto;manual
black level	manual	manual
PIV	-	-
readout control	-	-
flat field correction	-	-
shading correction	-	-
defect pixel correction	-	-
image flip	horizontal;vertical	horizontal;vertical
trigger int / ext / soft	x / x / x	x / x / x
trigger edge high / low sequencer	x / x	x / x

PWM power out	x	x
trigger IN TTL-24 V	2	2
outputs open drain	4	4
optical in / out	1 / -	1 / -
RS-232 in / out	1 / 1	1 / 1
RS-422 in / out	- / -	- / -
power supply	10...25 V	10...25 V

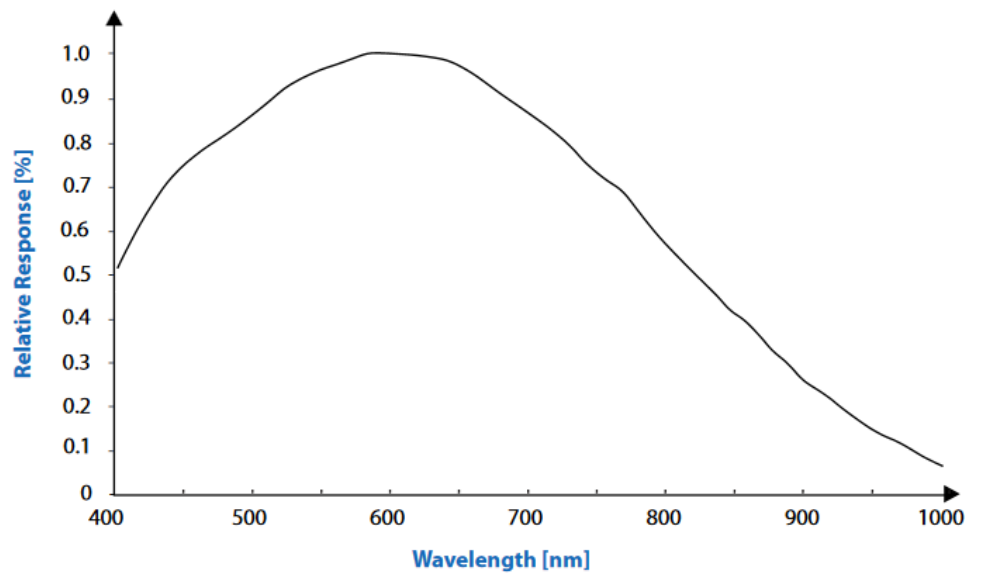
lens mount	C-Mount	C-Mount
dynamic lens control	-	-
size w / h / d (1)	50x50x34.12 mm	50x50x34.12 mm
weight	140 g	140 g
protection class	IP40	IP40
power consumption	4.0 W	4.0 W
operating temperature	-10...60°C	-10...60°C
humidity non-condensing	10...90 %	10...90 %
status	production	production

(1) please refer to drawings

Spectral sensitivity characteristics

Color

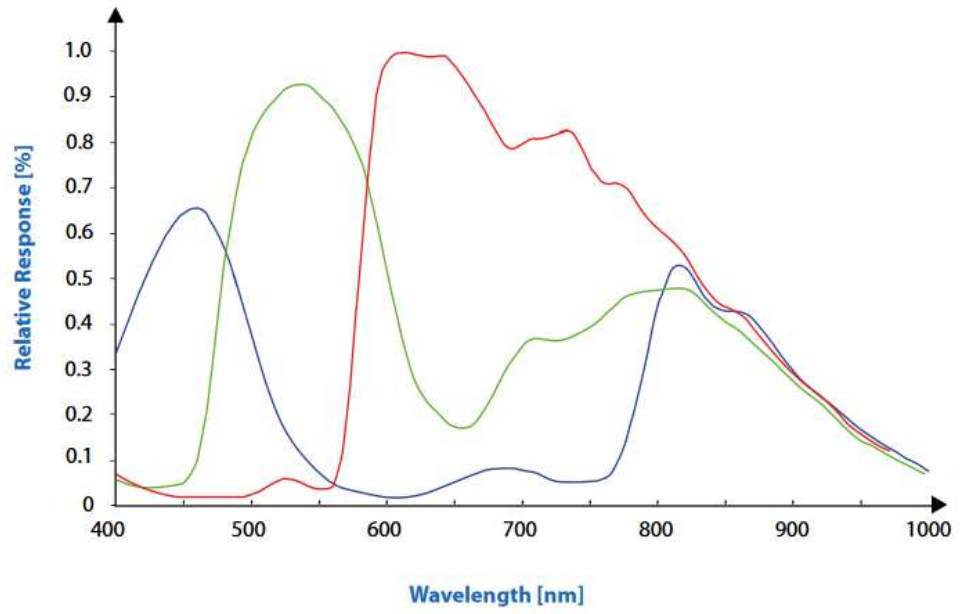

Figure 5: IMX304LQR

Mono

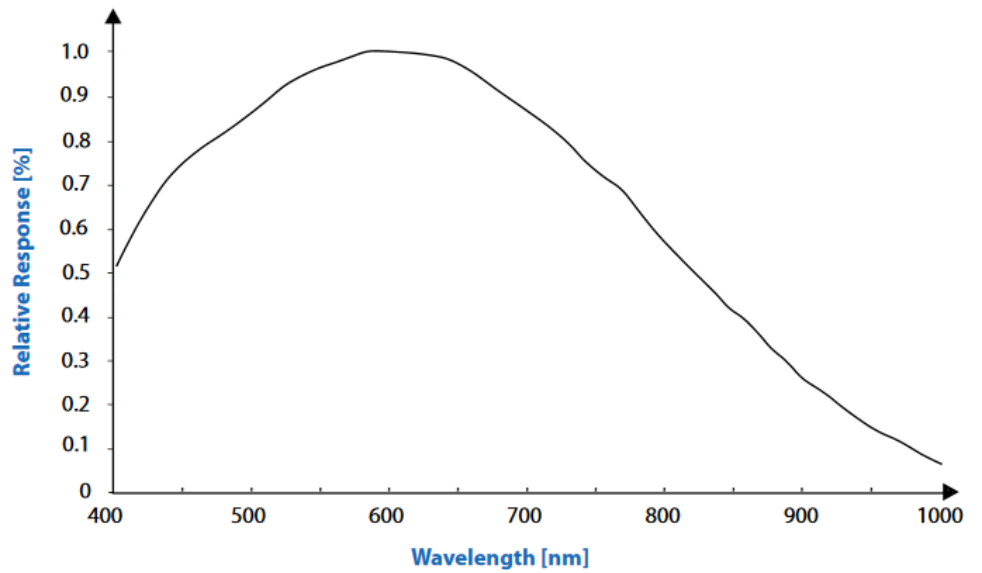

Figure 6: IMX304LLR

7 Dimensions

All length units in mm.

Find drawings in the web download area at

<https://www.svs-vistek.com/en/support/svs-support-download-center.php>

CAD step files available with valid login at [SVS-VISTEK.com](https://www.svs-vistek.com)

7.1 exo174*CL, exo249*CL, exo183*CL

front

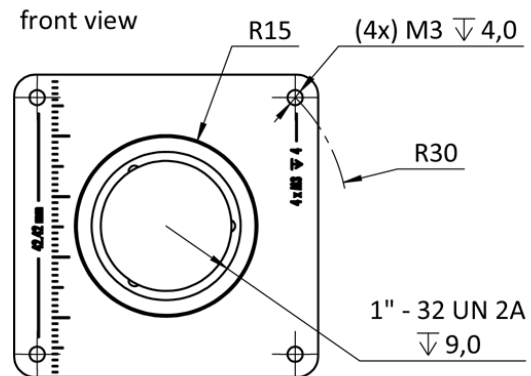

side Left

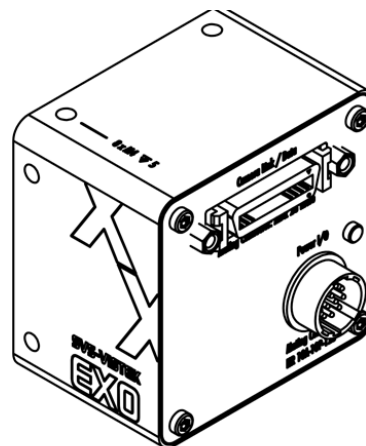

Side Right

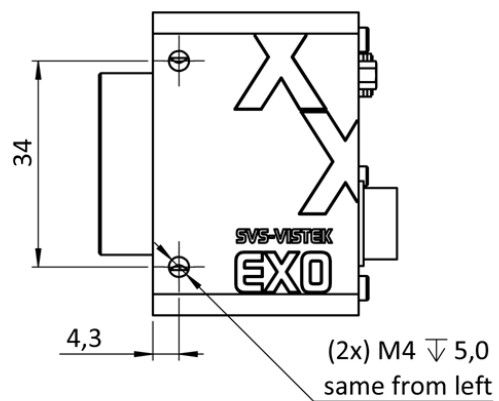

Top

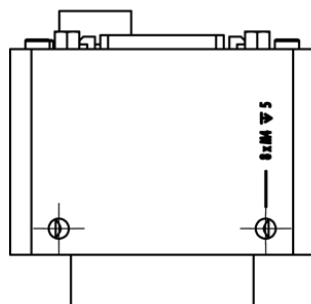

Bottom

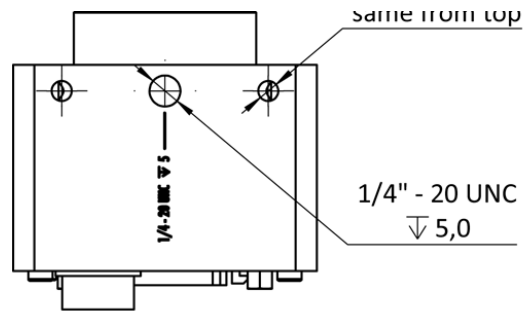

Back

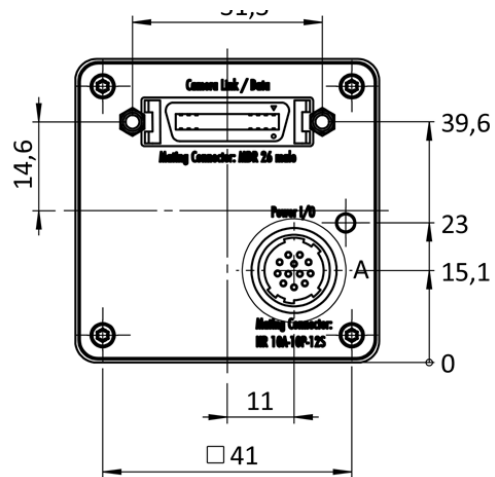

Cross Section

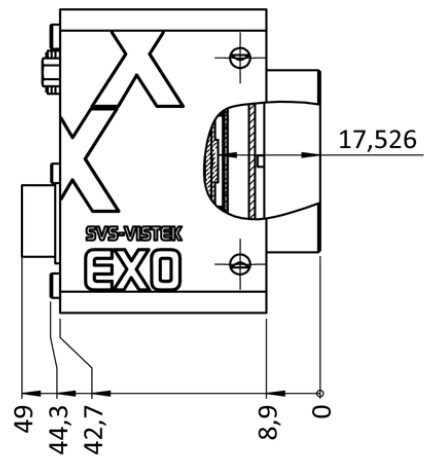

7.2 exo250*CL, exo252*CL

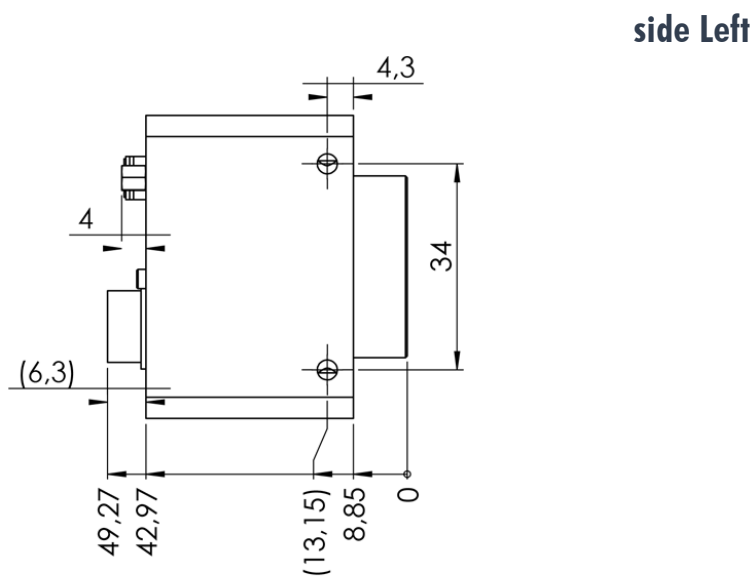
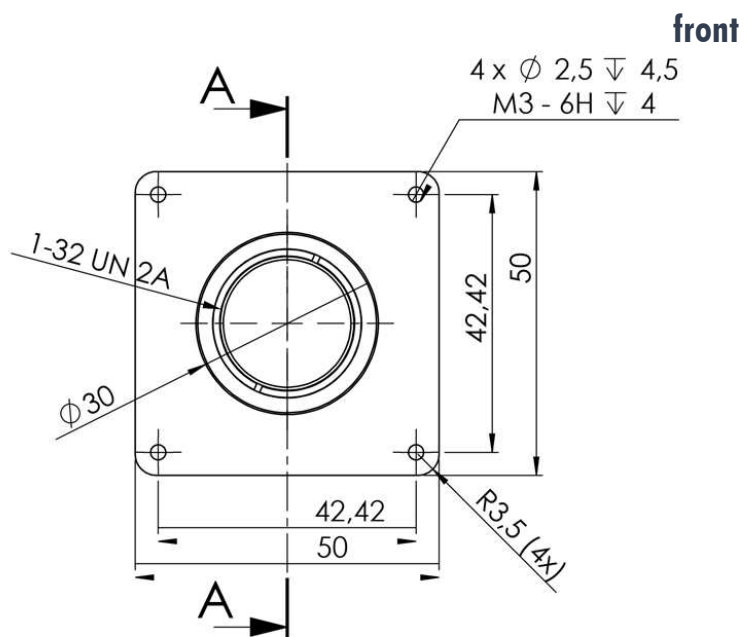

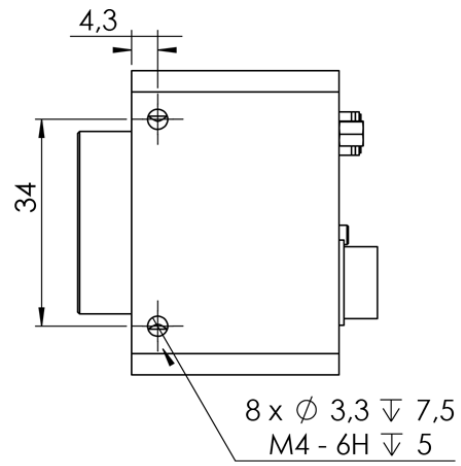
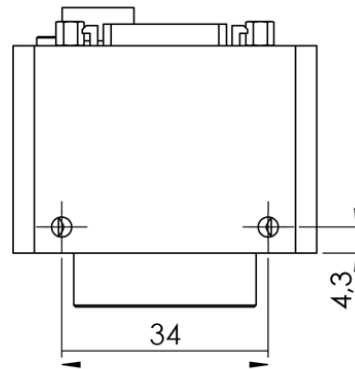
Side Right**Top**

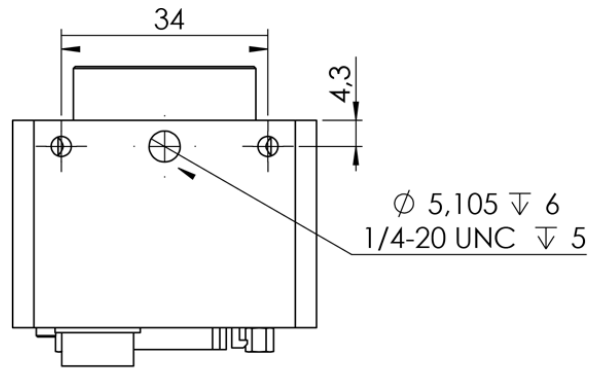
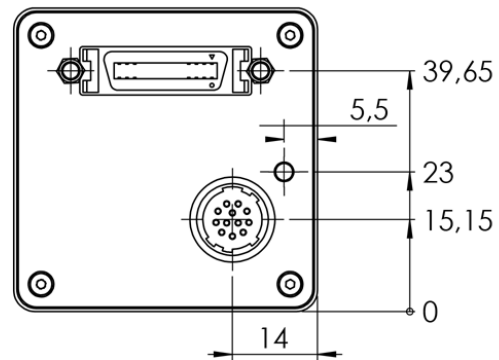
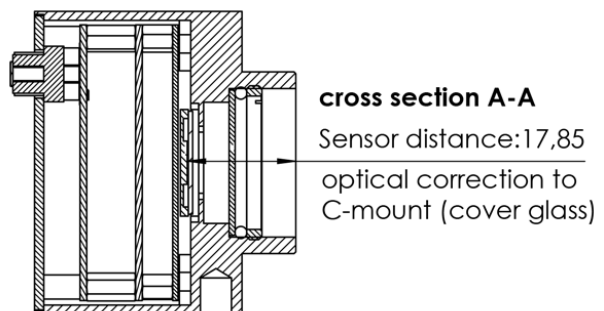
Bottom**Back****Cross Section**

7.3 exo267*CL, exo304*CL

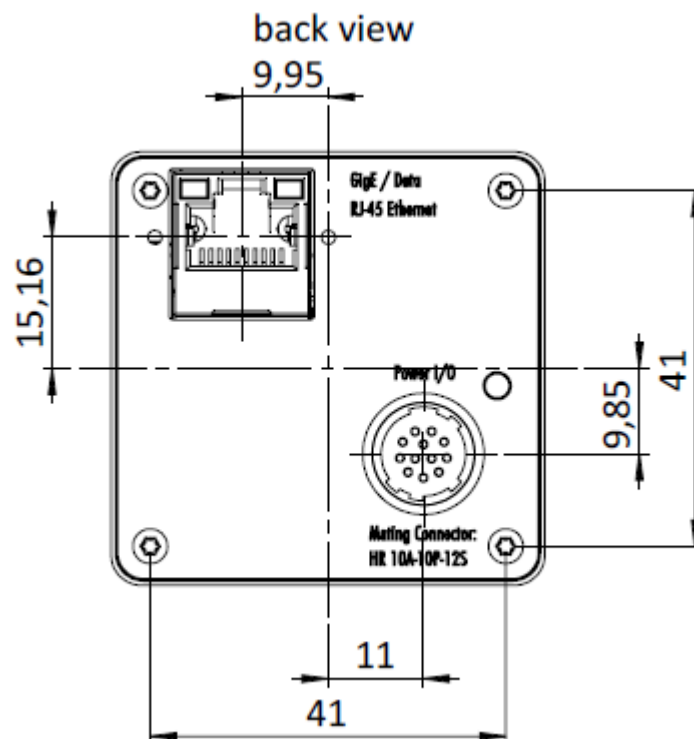
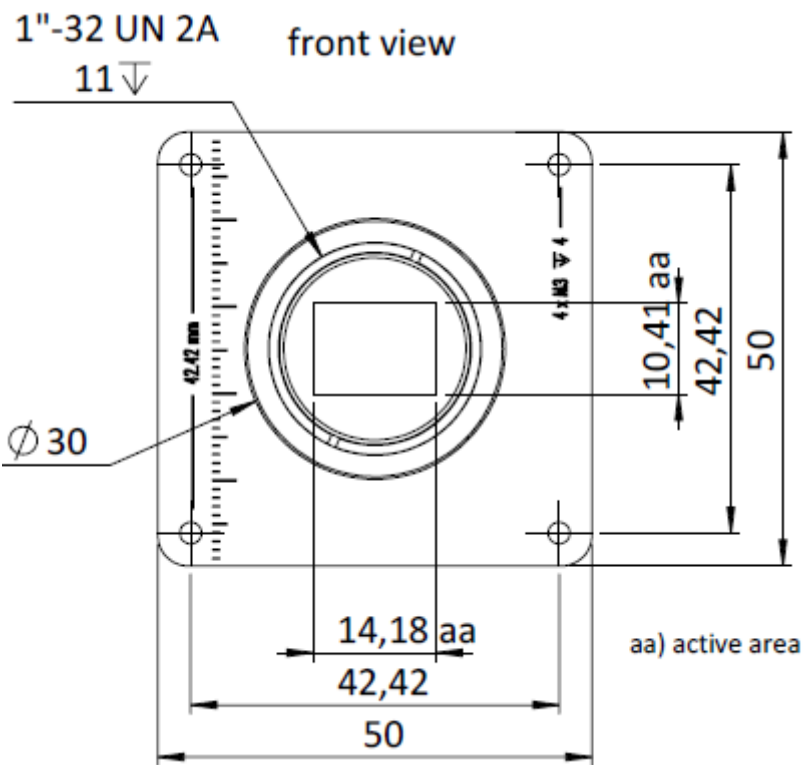

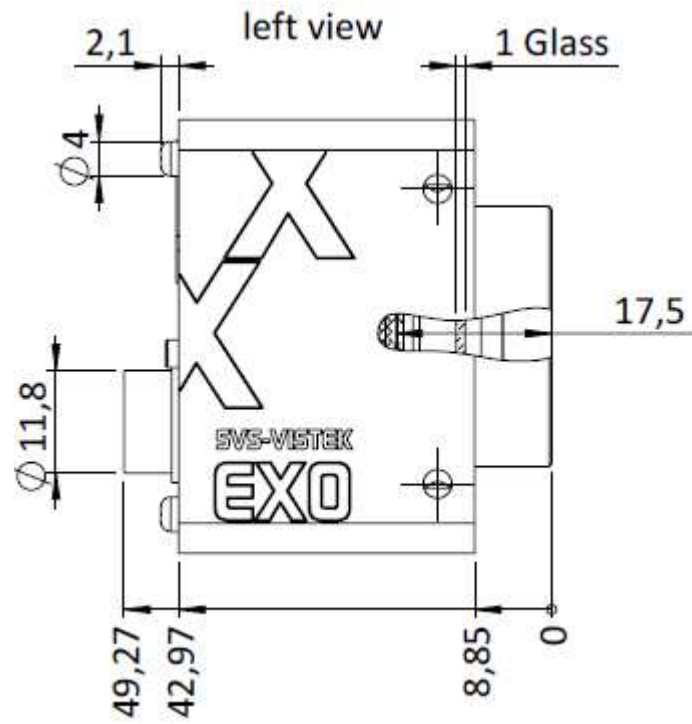

right view

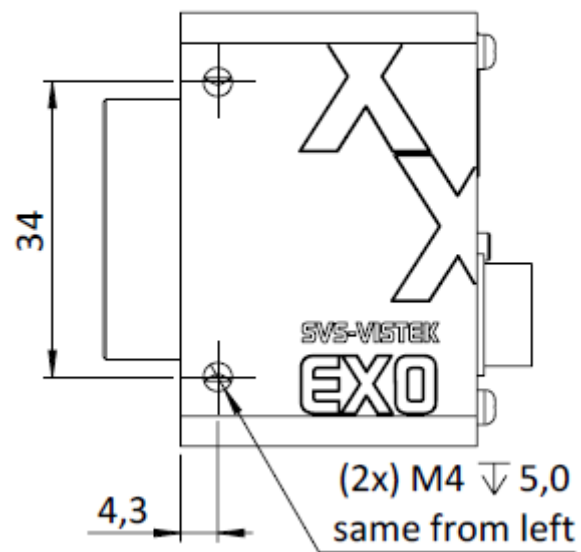

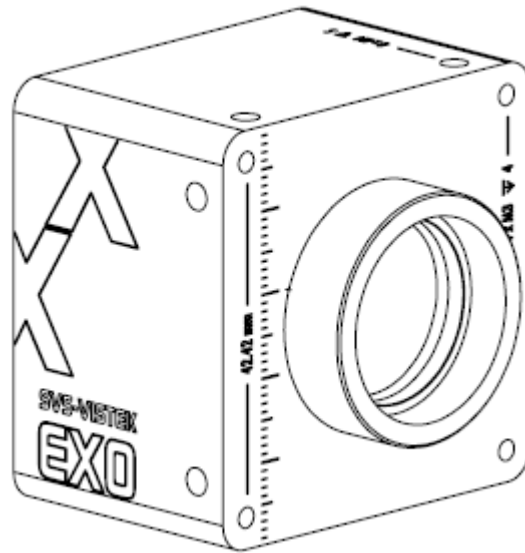
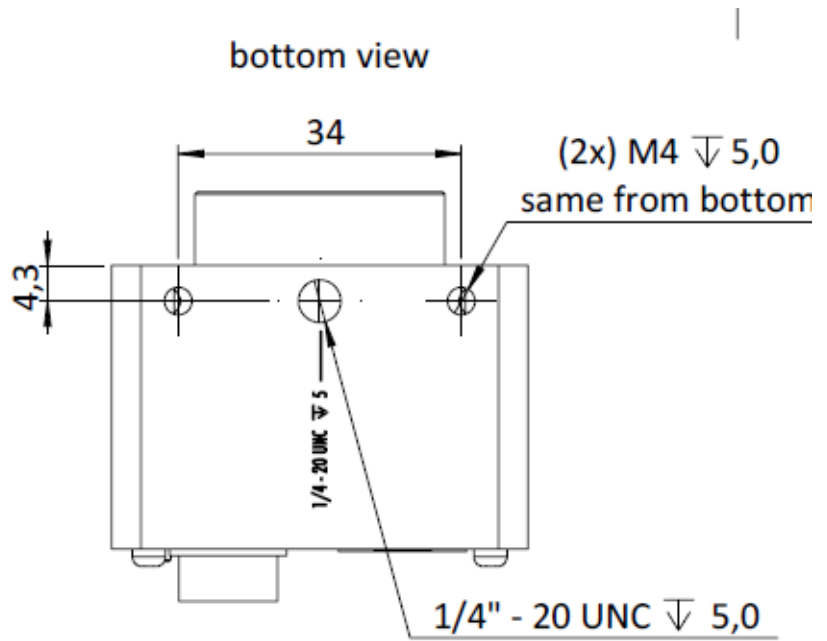

top view

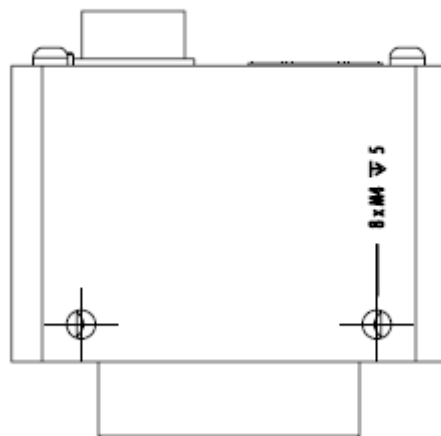

7.4 exo4000*CL

front

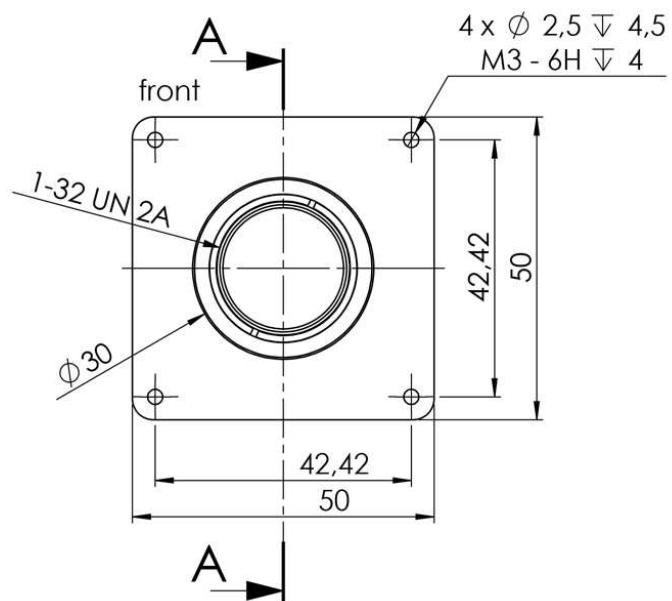

side Left

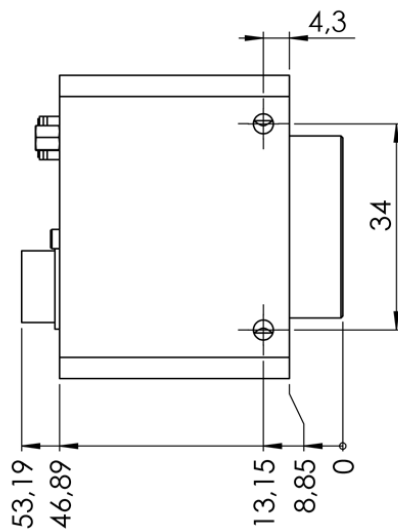

Side Right

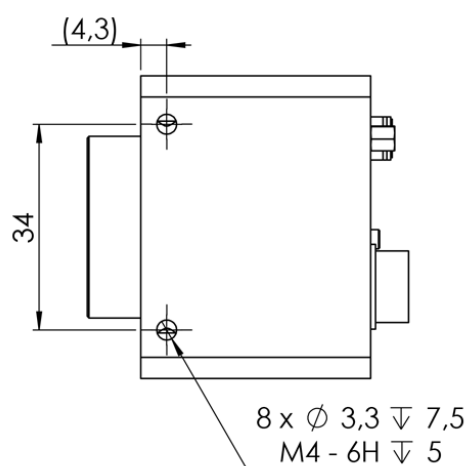

Top

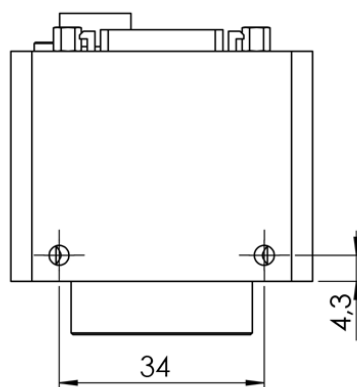

Bottom

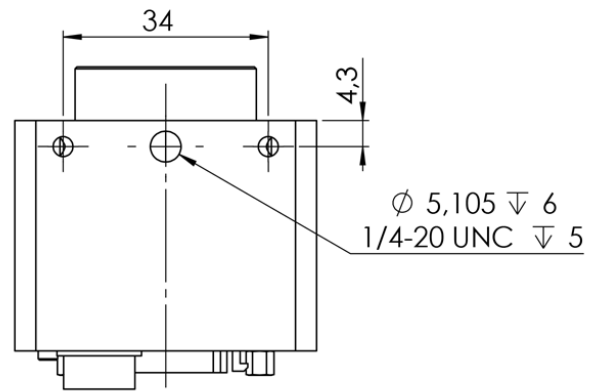

Back

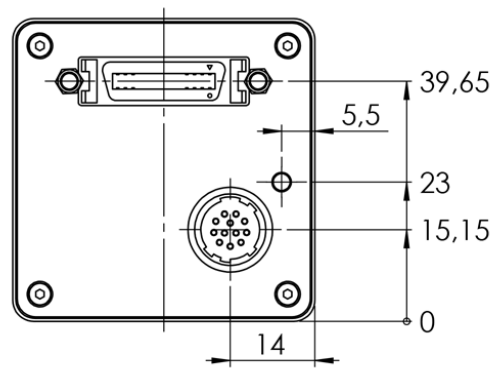

Cross Section

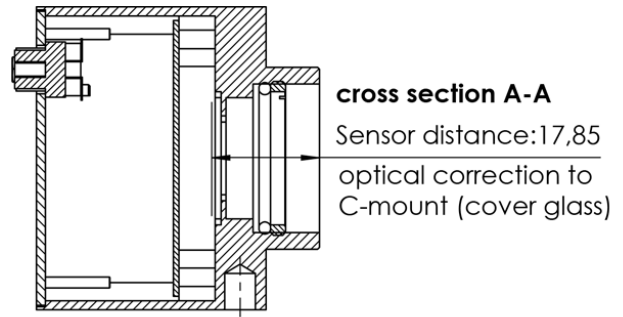

7.5 exo5000*CL

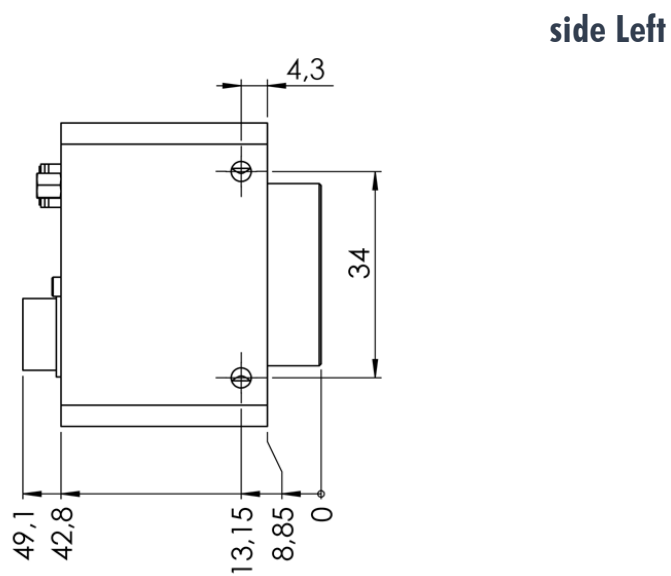
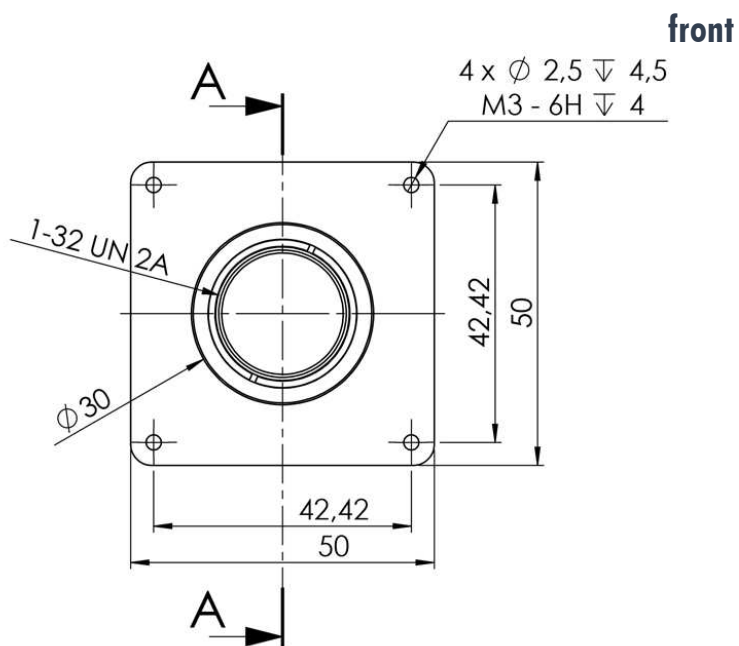

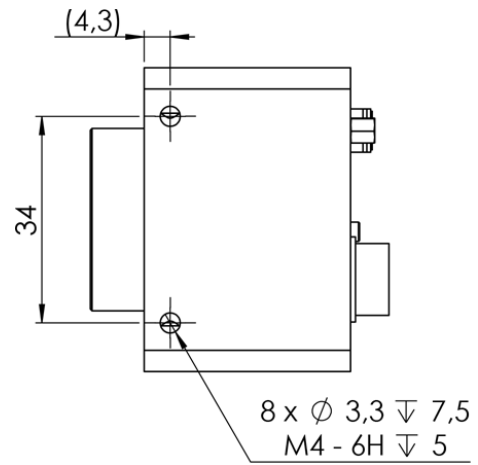
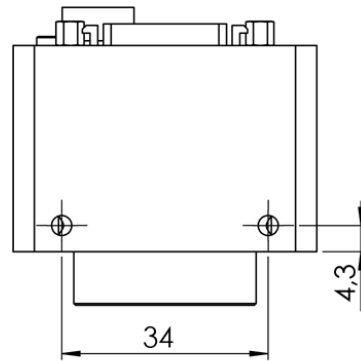
Side Right**Top**

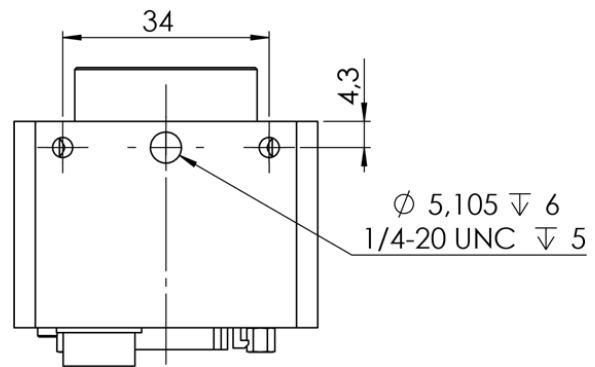
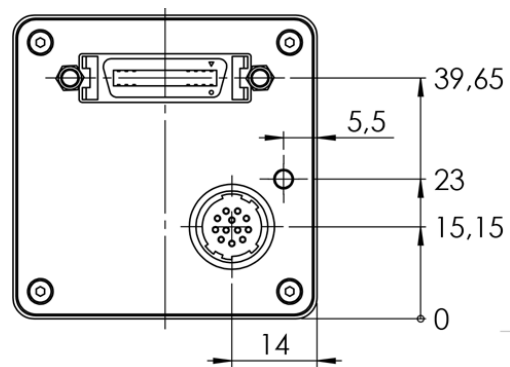
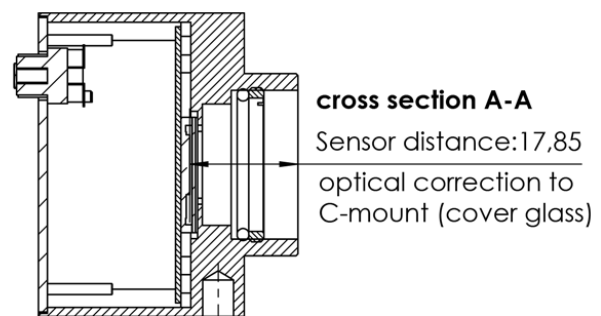
Bottom**Back****Cross Section**

7.6 C & CS mount

For C & CS mounts, different back focus distances from sensor to lens.

- > C-mount: 17,526 mm
- > CS-mount: 12,526 mm
- > Diameter: 1 inch
- > Screw threading: 1/32 inch

CS-mount cameras accept C and CS types of lenses. C-mount lenses require an additional 5mm adapter ring.

C-mount cameras only accept C mount lenses as the flange to sensor distance does not allow a CS mount lens close enough to the Sensor to achieve a focused image.

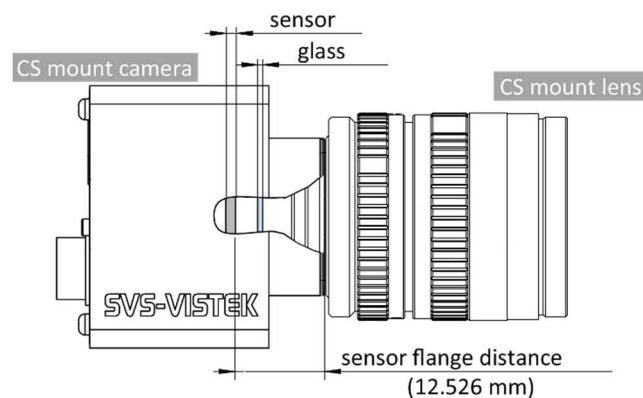
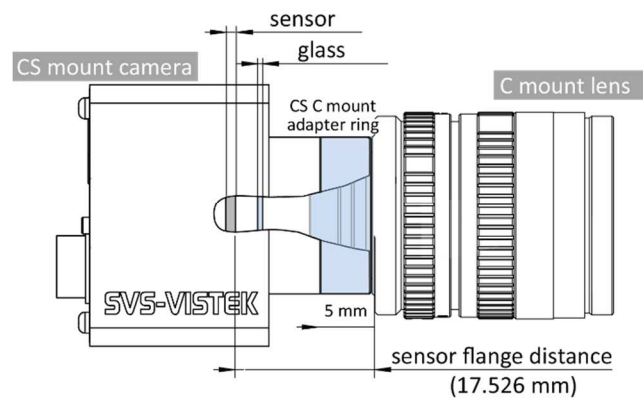
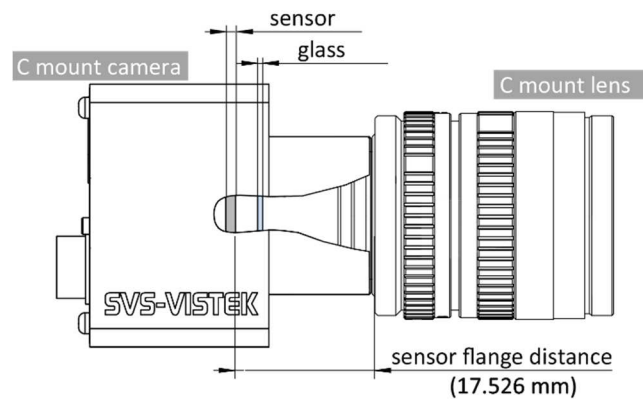

differences of C- & CS-mount

Note regarding lens screw in depth:

Maximum C-mount screw-in depth is 9.1 mm or 10.6mm image side flange distance if diameter does not exceed 20.6mm.

8 Terms of warranty

Standard Products Warranty and Adjustment	<p>Seller warrants that the article to be delivered under this order will be free from defects in material and workmanship under normal use and service for a period of 2 years from date of shipment. The liability of Seller under this warranty is limited solely to replacing or repairing or issuing credit (at the discretion of Seller) for such products that become defective during the warranty period. In order to permit Seller to properly administer this warranty, Buyer shall notify Seller promptly in writing of any claims,; provide Seller with an opportunity to inspect and test the products claimed to be defective. Such inspection may be on customer's premises or Seller may request return of such products at customer's expense. Such expense will subsequently be reimbursed to customer if the product is found to be defective and Buyer shall not return any product without prior return authorization from Seller. If a returned product is found to be out of warranty or found to be within the applicable specification, Buyer will have to pay an evaluation and handling charge, independent of possible repair and/or replacement costs. Seller will notify Buyer of the amount of said evaluation and handling charges at the time the return authorization is issued. Seller will inform Buyer of related repair and/or replacement costs and request authorization before incurring such costs. Buyer shall identify all returned material with Sellers invoice number, under which material has been received. If more than one invoice applies, material has to be clearly segregated and identified by applicable invoice numbers. Adjustment is contingent upon Sellers examination of product, disclosing that apparent defects have not been caused by misuse, abuse, improper installation of application, repair, alteration, accident or negligence in use, storage, transportation or handling. In no event shall Seller be liable to Buyer for loss of profits, loss of use, or damages of any kind based upon a claim for breach of warranty.</p>
Development Product Warranty	<p>Developmental products of Seller are warranted to be free from defects in materials and workmanship and to meet the applicable preliminary specification only at the time of receipt by Buyer and for no longer period of time in all other respects the warranties made above apply to development products. The aforementioned provisions do not extend the original warranty period of any article which has been repaired or replaced by Seller.</p>
Do not break Warranty Label	<p>If warranty label of camera is broken warranty is void. Seller makes no other warranties express or implied, and specifically, seller makes no warranty of merchantability of fitness for particular purpose.</p>
What to do in case of Malfunction	<p>Please contact your local distributor first.</p>

9 FAQ

Problem	Solution
Camera does not respond to light.	<p>Check if camera is set to "Mode 0". I.e. free running with programmed exposure ctrl. When done, check with the program "Convenient Cam" if you can read back any data from the camera, such as "Mode", "type" of CCD, exposure time settings, etc..</p> <p>If "Mode 0" works properly, check the signals of the camera in the desired operation mode like "Mode 1" or "Mode 2". In these modes, check if the ExSync signal is present. Please note that a TTL signal must be fed to the trigger connector if it is not provided by the frame grabber (LVDS type). The typical signal swing must be around 5 V. Lower levels will not be detected by the camera... If you use a TTL level signal fed to the "TB 5 connector" check the quality and swing. If these signals are not present or don't have the proper quality, the camera cannot read out any frame (Mode 1 and 2). Beware of spikes on the signal.</p>
Image is present but distorted.	<p>Check the camera configuration file of your frame grabber. Check number of "front- and back porch" pixel. Wrong numbers in configuration file can cause sync problems. Check if your frame grabber can work with the data rate of the camera.</p>
Image of a color version camera looks strange or false colors appear.	<p>If the raw image looks OK, check the camera file to see if the pixels need to be shifted by either one pixel or one line. The image depends on the algorithm used. If the algorithm is starting with the wrong pixel such effects appear.</p>
Colors rendition of a color versions not as expected – especially when using halogen light.	<p>Halogen light contains strong portions of IR radiation. Use cut-off filters at around 730 nm like "Schott KG 3" to prevent IR radiation reaching the CCD.</p>
No serial communication is possible between the camera and the PC.	<p>Use "load camera DLL" and try again.</p>

10 Glossary of Terms

Aberration	Spherical aberration occurs when light rays enter near the edge of the lens; Chromatic aberration is caused by different refractive indexes of different wavelengths of the light. (Blue is more refractive than red)
ADC	Analogue-to-Digital Converter, also known as A/D converter
Aperture	In optics, Aperture defines a hole or an opening through which light travels. In optical system the Aperture determines the cone angle of a bundle of rays that come to a focus in the image plane. The Aperture can be limited by an iris, but it is not solely reliant on the iris. The diameter of the lens has a larger influence on the capability of the optical system.
Bayer Pattern	A Bayer filter mosaic or pattern is a color filter array (CFA) deposited onto the surface of a CCD or CMOS sensor for capturing RGB color images. The filter mosaic has a defined sequence of red, green and blue pixels such that the captured image can be transported as a monochrome image to the host (using less bandwidth); where after the RGB information is recombined in a computer algorithm.
Binning	Binning combines the charge from two (or more) pixels to achieve higher dynamics while sacrificing resolution.
Bit-Depth	Bit-depth is the number of digital bits available at the output of the Analog-to-Digital Converter (ADC) indicating the distribution of the darkest to the brightest value of a single pixel.
Camera Link	Camera Link is a multiple-pair serial communication protocol standard [1] designed for computer vision applications based on the National Semiconductor interface Channel-link. It was designed for the purpose of standardizing scientific and industrial video products including cameras, cables and frame grabbers.
CCD	Charge Coupled Device. Commonly used technology used for camera sensors used to detect & quantify light, i.e. for capturing images in an electronic manner. CCDs were first introduced in the early 70ies.
CMOS	Complementary Metal–Oxide–Semiconductor. A more recently adopted technology used for camera sensors with in-pixel amplifiers used to detect & quantify light, i.e. capturing images in an electronic manner.
CPU	Central Processing Unit of a computer. Also referred to as the processor chip.
dB	Decibel (dB) is a logarithmic unit used to express the ratio between two values of a physical quantity.
Decimation	For reducing width or height of an image, decimation can be used (CMOS sensors only). Columns or rows can be ignored. Image readout time is thereby reduced.
Defect map	Identifies the location of defect pixels unique for every sensor. A factory generated defect map is delivered and implemented with each camera.
EPROM	Erasable Programmable Read Only Memory is a type of memory chip that retains its data when its power supply is switched off.
External Trigger	Erasable Programmable Read Only Memory is a type of memory chip that retains its data when its power supply is switched off.
fixed frequency	or programmed exposure time. Frames are read out continuously.
Gain	In electronics, gain is a measure of the ability of a two-port circuit (often an amplifier) to increase the power or amplitude of a signal from the input to the output port by adding energy to the signal.

Gamma	Gamma correction is a nonlinear operation used to code and decode luminance values in video or still image systems.
GenICam	Provides a generic programming interface for all kinds of cameras and devices. Regardless what interface technology is used (GigE Vision, USB3 Vision, CoaXPress, Camera Link, etc.) or which features are implemented, the application programming interface (API) will always be the same.
GigE Vision	GigE Vision is an interface standard introduced in 2006 for high-performance industrial cameras. It provides a framework for transmitting high-speed video and related control data over Gigabit Ethernet networks.
GPU	Graphics Processing Unit of a computer.
Hirose	Cable connectors commonly used for power, triggers, I/Os and strobe lights
ISO	see Gain.
Jumbo Frames	In computer networking, jumbo frames are Ethernet frames with more than 1500 bytes of payload. Conventionally, jumbo frames can carry up to 9000 bytes of payload. Some Gigabit Ethernet switches and Gigabit Ethernet network interface cards do not support jumbo frames.
Mount	Mechanical interface/connection for attaching lenses to the camera.
Multicast	Multicast (one-to-many or many-to-many distribution) is an ethernet group communication where information is addressed to a group of destination computers simultaneously. Multicast should not be confused with physical layer point-to-multipoint communication.
PWM	Pulse width modulation. Keeping voltage at the same level while limiting current flow by switching on an off at a very high frequency.
Partial Scan	A method for reading out fewer lines from the sensor, but “skipping” lines above and below the desired area. Typically applied to CCD sensors. In most CMOS image sensors an AOI (area of interest) or ROI (region of interest) can be defined by selecting the area to be read. This leads to increased frame rate.
Pixel clock	The base clock (beat) that operates the sensor chip is. It is typically also the clock with which pixels are presented at the output node of the image sensor.
RAW	A camera RAW image file contains minimally processed data from the image sensor. It is referred as raw in its meaning. SVS-VISTEK plays out RAW only.
Read-Out-Control	Read-Out control defines a delay between exposure and image readout. It allows the user to program a delay value (time) for the readout from the sensor. It is useful for preventing CPU overload when handling very large images or managing several cameras on a limited Ethernet connection.
Shading	Shading manifests itself a decreasing brightness towards the edges of the image or a brightness variation from one side of the image to the other. Shading can be caused by non-uniform illumination, non-uniform camera sensitivity, vignetting of the lens, or even dirt and dust on glass surfaces (lens).
Shading correction	An in-camera algorithm for real time correction of shading. It typically permits user configuration. By pointing at a known uniform evenly illuminated surface it allows the microprocessor in the camera to create a correction definition, subsequently applied to the image during readout.
Shutter	Shutter is a device or technique that allows light to pass for a determined period of time, exposing photographic film or a light-sensitive electronic sensor to light in order to capture a permanent image of a scene.

Strobe light	<p>A bright light source with a very short light pulse. Ideal for use with industrial cameras, e.g. for “freezing” the image capture of fast moving objects. Can often be a substitute for the electronic shutter of the image sensor. Certain industrial cameras have dedicated in-camera output drivers for precisely controlling one or more strobe lights.</p>
Tap	<p>CCD sensors can occur divided into two, four or more regions to double/quadruple the read out time.</p>
TCP/IP	<p>TCP/IP provides end-to-end connectivity specifying how data should be packetized, addressed, transmitted, routed and received at the destination.</p>
USB3 Vision	<p>The USB3 Vision interface is based on the standard USB 3.0 interface and uses USB 3.0 ports. Components from different manufacturers will easily communicate with each other.</p>
Trigger modes	<p>Cameras for industrial use usually provide a set of different trigger modes with which they can be operated. The most common trigger modes are: (1) Programmable shutter trigger mode. Each image is captured with a pre-defined shutter time; (2) Pulse-Width Control trigger. The image capture is initiated by the leading edge of the trigger pulse and the shutter time is governed by the width of the pulse; (3) Internal trigger or Free-Running mode. The camera captures images at the fastest possible frame rate permitted by the readout time.</p>
XML Files	<p>Extensible Markup Language (XML) is a markup language that defines a set of rules for encoding documents in a format which is both human-readable and machine-readable</p>