



COAXPRESS CAMERAS

Bonito PRO

Technical Manual

V1.0.6

**Quick links**

- [Bonito PRO cameras at a glance](#) on page 14
- [Contact us](#) on page 16
- [Contents](#) on page 17

# Read before use

## EN - English

### Safety

Before using the camera, read these safety instructions. Observe the warnings at all times. Use the camera only as stated in the [Intended use](#) on page 28.

**CAUTION****Risk of burns**

A camera in operation can reach temperature levels which could cause burns.

**CAUTION****Injury by falling cameras or lenses**

A falling camera or lens can cause injury.

**CAUTION****Risk of cuts by sharp edges of lens mounts**

The threads of the lens mount can have sharp edges.

### Intended use

Intended use of Allied Vision product is the integration into vision systems by professionals. All Allied Vision product is sold in a B2B setting.

## DA - Dansk

### Sikkerhed

Læs sikkerhedsanvisningerne, før kameraet bruges. Overhold alle advarsler. Brug kun kameraet som anført i [Intended use](#) på side 28.



#### **FORSIGTIG**

##### **Forbrændingsfare**

Når kameraet bruges, kan det blive meget varmt og forårsage forbrændinger.



#### **FORSIGTIG**

##### **Kvæstelser, hvis kameraet eller linser falder ned**

Falder kameraet eller linsen ned, kan dette forårsage kvæstelser.



#### **FORSIGTIG**

##### **Fare for snitsår på linsemodulets skarpe kanter**

Linsemodulets gevind kan have skarpe kanter.

### Tilsigtet brug

Allied Vision produktets tilsigtede brug er en indbygning i et visionssystem, udført af fagfolk. Alle Allied Vision produkter sælges i B2B.

## DE - Deutsch

### Sicherheit

Bevor Sie die Kamera benutzen, lesen diese Sicherheitshinweise. Beachten Sie diese Hinweise immer. Verwenden Sie die Kamera nur wie beschrieben in [Intended use](#) auf Seite 28.



#### VORSICHT

##### **Gefahr von Verbrennungen**

Im Betrieb kann die Kamera Temperaturen erreichen, die zu Verbrennungen führen.



#### VORSICHT

##### **Verletzung durch fallende Kameras oder Objektive**

Eine fallende Kamera oder ein fallendes Objektiv kann Verletzungen verursachen.



#### VORSICHT

Schnitte durch scharfkantige Objektivgewinde

Objektivgewinde können scharfe Kanten haben.

### Bestimmungsgemäßer Gebrauch

Allied Vision Produkte sind bestimmt für die Integration in Bildverarbeitungssysteme durch Fachpersonal. Alle Allied Vision Produkte werden in einer B2B-Umgebung verkauft.

## ES - Español

### Seguridad

Antes de utilizar la cámara lea estas instrucciones de seguridad. Observe las advertencias en todo momento. Utilice la cámara solo tal y como se estipula en el [Intended use](#) en la página 28.



#### ATENCIÓN

##### **Riesgo de quemaduras**

Una cámara en funcionamiento puede alcanzar temperaturas que podrían provocar quemaduras.



#### ATENCIÓN

##### **Lesiones en caso de que las cámaras o las lentes se caigan**

Si una cámara o una lente se cae puede provocar lesiones.



#### ATENCIÓN

##### **Riesgo de cortes debido a los bordes afilados del objetivo**

Las roscas de los objetivos pueden tener bordes afilados.

### Uso previsto

El uso previsto del producto Allied Vision es la integración en el sistema de visión por parte de profesionales. Todos los productos Allied Vision se venden dentro de una relación B2B.

## FI - Suomi

### Turvallisuus

Lue nämä turvallisuusohjeet ennen kameran käyttöä. Noudata varoituksia joka hetki. Käytä kameraa ainoastaan kohdassa [Intended use](#) sivulla 28 kuvatulla tavalla.



#### **HUOMIO**

##### **Palovammojen vaara**

Käytössä olevan kameran saavuttamat lämpötilatasot voivat aiheuttaa palovammoja.



#### **HUOMIO**

##### **Putoavien kameroiden tai linssien aiheuttamat vammat**

Putoava kamera tai linssi voi aiheuttaa vammoja.



#### **HUOMIO**

##### **Linssien kiinnikkeiden terävien reunojen aiheuttamien viiltovammojen vaara**

Linssin kiinnikkeiden kierteiden reunat voivat olla teräviä.

### Käyttötarkoitus

Allied Vision-tuotteen käyttötarkoitus on integrointi kuvajärjestelmiin ammattilaisten toimesta. Kaikki Allied Vision-tuotteet myydään B2B-ympäristössä.

## FR - Français

### Sécurité

Veillez lire ces consignes de sécurité avant d'utiliser la caméra. Respectez continuellement les avertissements. Utilisez la caméra uniquement comme indiqué sous [Intended use](#), page 28.



#### ATTENTION

##### Risque de brûlures

Une caméra en service peut atteindre des niveaux de température susceptibles d'entraîner des brûlures.



#### ATTENTION

##### Blessures en cas de chute de caméras ou d'objectifs

La chute d'une caméra ou d'un objectif peut entraîner des blessures.



#### ATTENTION

##### Risque de coupures sur les bords tranchants des montures d'objectif

Les filetages des montures d'objectif peuvent présenter des bords tranchants.

### Utilisation prévue

L'utilisation prévue du produit Allied Vision est son intégration dans des systèmes de vision par le soin de professionnels. Tout produit Allied Vision est vendu dans un cadre B2B.

## IT - Italiano

### Sicurezza

Leggere queste istruzioni per la sicurezza prima di utilizzare la telecamera. Osservare sempre tutte le avvertenze. Utilizzare la telecamera come descritto alla sezione [Intended use](#) a pagina 28.



#### ATTENZIONE

##### **Pericolo di ustioni**

Durante il funzionamento una telecamera può raggiungere temperature elevate che possono essere causa di ustioni.



#### ATTENZIONE

##### **Lesioni dovute alla caduta di telecamere o lenti**

La caduta di una telecamera o di una lente può causare delle lesioni.



#### ATTENZIONE

##### **Pericolo di tagliarsi sui bordi affilati degli attacchi della lente**

I bordi della filettatura dell'attacco della lente possono essere affilati.

### Uso previsto

Il prodotto Allied Vision è concepito per essere integrato in sistemi di monitoraggio in campo professionale. Tutti i prodotti Allied Vision sono venduti in uno scenario B2B.



# JA – 日本語

## 安全性

本カメラを使用する前に、この安全の手引きをお読みください。常に、警告事項を守ってください。必ず、[Intended use](#) 28 ページの通りに、本カメラを使用してください。



### 注意

#### やけどの危険性

作動中のカメラは、やけどを引き起こす温度まで熱くなる恐れがあります。



### 注意

#### カメラまたはレンズの落下によるけが

カメラまたはレンズが落下すると、けがをする恐れがあります。



### 注意

#### レンズマウントの鋭利な端部で切り傷の危険性

レンズマウントのギザギザの部分が鋭利である可能性があります。

## 用途

Allied Vision製品は、専門家が視覚装置に統合することを意図したものです。すべてのAllied Vision製品は、企業間取り引き用に販売されています。

## NL - Nederlands

### Veiligheid

Lees deze veiligheidsinstructies voordat u de camera gaat gebruiken. Neem deze waarschuwingen altijd in acht. Gebruik de camera uitsluitend, zoals aangegeven in het [Intended use](#) op pagina 28.



#### VOORZICHTIG

##### Risico van verbranding

Een camera die gebruikt wordt, kan temperatuurwaarden bereiken die brandwonden kunnen veroorzaken.



#### VOORZICHTIG

##### Letsel door vallende camera's of lenzen

Een vallende camera of lens kan letsel veroorzaken.



#### VOORZICHTIG

##### Risico van snijwonden door scherpe randen van lensbevestigingen

Het schroefdraad van de lensbevestiging kan scherpe randen hebben.

### Beoogd gebruik

Het beoogde gebruik van het Allied Vision-product is de integratie in optische systemen door professionals. Alle Allied Vision-producten worden verkocht in de B2B-markt.

## NO - Norsk

### Sikkerhet

Les disse sikkerhetsinstruksene før du bruker kameraet. Følg advarslene til en hver tid. Bruk kun kameraet i samsvar med [Intended use](#) på side 28.



#### FORSIKTIG

##### Risiko for brannskader

Et kamera i bruk kan nå temperaturnivåer som kan forårsake brannskader.



#### FORSIKTIG

##### Skade ved fallende kameraer eller linser

Et fallende kamera eller en fallende linse kan forårsake skade.



#### FORSIKTIG

##### Risiko for kutt fra skarpe kanter på linsefester

Sporene på linsefestet kan ha skarpe kanter.

### Tiltenkt bruk

Den tiltenkte bruken av Allied Vision-produktet er integrering i visjonssystemer av profesjonelle. Alle Allied Vision-produkter selges i en forretning til forretning-situasjon.

## SV - Svenska

### Säkerhet

Läs igenom säkerhetsinstruktionerna innan du använder kameran. Var hela tiden särskilt uppmärksam på varningarna. Använd enbart kameran på det sätt som anges i [Intended use](#) på sida 28.



#### VARNING

##### **Risk för brännskada**

En kamera i drift kan komma upp i temperaturer som kan orsaka brännskador.



#### VARNING

##### **Risk för skador från fallande kameror eller objektiv**

Fallande kameror eller objektiv kan förorsaka skador.



#### VARNING

##### **Risk för skärsår från vassa kanter på objektivfattningar**

Objektivets gängor kan ha vassa kanter.

### Avsedd användning

Den avsedda användningen av Allied Vision-produkter är integrering i visionssystem av fackmän. Samtliga Allied Vision-produkter säljs i en B2B-miljö.

# ZH - 英文简体中文版

## 安全需知

使用本相机前，请阅读本安全说明书。请务必遵守相关警告 和 [Intended use](#) 于第 28 页。



### 注意事项

#### 烫伤风险

相机操作过程中温度可能上升并导致烫伤风险。



### 注意事项

#### 相机或者镜头跌落造成伤害

相机或者镜头可能会跌落并造成伤害。



### 注意事项

#### 镜头接口的锐利边缘划伤风险

镜头接口螺纹边缘可能较为锐利。

## 预期用途

Allied Vision 产品的预期用途是由专业人士整合到视觉系统中。所有 Allied Vision 的产品均通过 B2B 渠道销售。

# Bonito PRO cameras at a glance



Get an overview of Bonito PRO camera documentation.



### Read this document carefully

Learn how to protect your Bonito PRO camera from damage and fully understand its functions.

The Bonito PRO is Allied Vision's high-bandwidth camera series with a CoaXPress interface. Equipped with four DIN 1.0/2.3 connectors the camera is capable to transmit 25 Gbps via quad CXP-6 (6.25 Gbps) high-speed connections. The Bonito PRO features a rugged, fan-less housing design and its powerful feature set make this camera an ideal choice for high-definition imaging applications demanding high-throughput, robustness, and system design-in flexibility.

## Scope of delivery

Your Allied Vision camera is delivered with the following components:

- Bonito PRO CXP-6 camera
- Download Instructions

## What else do you need?

Content	URL
Bonito PRO Features Reference, camera data sheets, Modular Concept, 3D CAD STEP files	<a href="http://alliedvision.com/en/support/technical-documentation/bonito-PRO-documentation.html">alliedvision.com/en/support/technical-documentation/bonito-PRO-documentation.html</a>
Technical papers and knowledge base	<a href="http://alliedvision.com/en/support/technical-papers-knowledge-base.html">alliedvision.com/en/support/technical-papers-knowledge-base.html</a>
Download the latest firmware and release notes	<a href="http://alliedvision.com/en/support/firmware.html">alliedvision.com/en/support/firmware.html</a>
JiIA CoaXPress Vision Standard Version 1.1.1	<a href="http://Jiia.org/en/">Jiia.org/en/</a>
EMVA GenICam SFNC Version 2.2	<a href="http://emva.org/standards-technology/genicam/genicam-downloads/">emva.org/standards-technology/genicam/genicam-downloads/</a>
Camera lenses and accessories	<a href="http://alliedvision.com/en/products/accessories.html">alliedvision.com/en/products/accessories.html</a>

Table 1: Additional resources

# Contact us

## Website

General

[www.alliedvision.com/en/contact](http://www.alliedvision.com/en/contact)

Distribution partners

[www.alliedvision.com/en/about-us/where-we-are](http://www.alliedvision.com/en/about-us/where-we-are)

## Email

General

[info@alliedvision.com](mailto:info@alliedvision.com)

Support

[support@alliedvision.com](mailto:support@alliedvision.com)

## Sales offices

Europe, Middle East, and Africa

T// +49 36428 677-230

North and South America

Toll-free: +1 877 USA 1394

T// +1 978 225 2030

California: +1 408 721 1965

Asia-Pacific

T// +65 6634 9027

China

T// +86 21 64861133

## Headquarters

Allied Vision Technologies GmbH

Taschenweg 2a

07646 Stadtroda, Germany

T// +49 36428 677-0

F// +49 36428 677-28



# Contents

Read before use	2
EN - English	2
DA - Dansk	3
DE - Deutsch	4
ES - Español	5
FI - Suomi	6
FR - Français	7
IT - Italiano	8
<b>JA - 日本語</b>	9
NL - Nederlands	10
NO - Norsk	11
SV - Svenska	12
ZH - 英文简体中文版	13
<b>Bonito PRO cameras at a glance</b>	<b>14</b>
Scope of delivery	15
What else do you need?	15
<b>Contact us</b>	<b>16</b>
<b>Document history and conventions</b>	<b>20</b>
Document history	21
Manual conventions	22
Typographic styles	22
Acronyms and terms	23
<b>Compliance, safety, and intended use</b>	<b>25</b>
Compliance notifications	26
Intended use	28
Copyright and trademarks	28
Your safety	29
Handling lens mounts	29
Handling hot cameras	29
Providing optimum heat dissipation	29
Camera mounting	30
Product safety	31
Electrical connections	31
Optical components	32
<b>Installing the camera</b>	<b>33</b>
Touching hot cameras	34
Electrostatic discharge	34
Frame grabbers	35
Recommended frame grabbers	35
Mounting the camera	36

Mounting the lens . . . . .	37
Planarity mounts . . . . .	38
Cameras and lens load . . . . .	39
Powering the camera . . . . .	39
Connecting your camera . . . . .	41
Accessories . . . . .	43
<b>Specifications</b>	<b>44</b>
Applied standards . . . . .	45
J11A CoaXPress . . . . .	45
GenICam™ . . . . .	45
Shock and vibration . . . . .	45
Notes on specifications . . . . .	46
Resolution and ROI frame rates . . . . .	46
Absolute QE plots . . . . .	46
Specifications common to all models . . . . .	47
Trigger jitter, delay, and propagation delay . . . . .	48
Bonito PRO X-1250 series . . . . .	49
Absolute QE . . . . .	50
Spectral response . . . . .	50
ROI frame rates . . . . .	51
Bonito PRO X-2620 series . . . . .	53
Absolute QE . . . . .	54
Spectral response . . . . .	54
ROI frame rates . . . . .	55
Camera features . . . . .	57
<b>Mechanical dimensions</b>	<b>58</b>
Bonito PRO housing and mounts . . . . .	59
F-Mount (default mount) . . . . .	59
F-Mount PA . . . . .	60
EF-Mount PA . . . . .	61
M42-Mount . . . . .	62
M42-Mount PA . . . . .	63
M58-Mount . . . . .	64
M58-Mount PA . . . . .	65
Flange focal distance . . . . .	66
F-Mount . . . . .	66
F-Mount PA . . . . .	66
EF-Mount PA . . . . .	67
M42-Mount . . . . .	67
M42-Mount PA . . . . .	68
M58-Mount . . . . .	68
M58-Mount PA . . . . .	69
Adjustment of F-Mount . . . . .	69
Planarity adjustable mounts . . . . .	70
Sensor position accuracy . . . . .	71
Optical filters . . . . .	72

<b>Camera interfaces</b>	<b>73</b>
Back panel	74
Status LEDs	75
CoaXPress interface	76
Maximum cable length	76
CoaXPress physical topology	76
Camera I/O connector pin assignment	78
I/O definition	80
Camera Power	80
Input triggers	80
Output signals	82
EF lens control	84
Camera trigger	85
Trigger timing diagram	85
Trigger definitions	85
<b>Image data flow</b>	<b>87</b>
Bonito PRO image data flow	88
<b>Cleaning optical components</b>	<b>89</b>
Keep optical components clean	90
Identifying impurities	90
Locating impurities	91
Materials for cleaning optical components	91
Cleaning instructions	92
Workplace pre-conditions	92
Cleaning instructions	92
Cleaning issues	93
Cleaning with compressed air	93
<b>Firmware update</b>	<b>94</b>
Firmware upgrade overview	95
Get remote port and device node map	96
Collect features for FileAccess	96
Firmware upload via FileAccess	97
<b>Index</b>	<b>101</b>

# Document history and conventions



This chapter includes:

- Document history
- Layout styles and symbols used in this manual
- Acronyms and terms used in this manual

## Document history

Version	Date	Remarks
V1.0.6	2020-Jun-05	<ul style="list-style-type: none"> <li>Updated compliance chapter</li> <li>Updated <a href="#">Installing the camera</a> on page 33</li> <li>Added <a href="#">Read before use</a> on page 2</li> <li>Added <a href="#">Your safety</a> on page 29</li> <li>Added <a href="#">Product safety</a> on page 31</li> <li>Updated <a href="#">Compliance notifications</a> on page 26</li> <li>Added spectral response plots</li> <li>Editorial changes</li> </ul>
V1.0.5	2019-Dec-03	<ul style="list-style-type: none"> <li>Corrected Binning Horizontal values</li> <li>Updated the optical filter plot</li> <li>Corrected Canadian ICES compliance statement</li> </ul>
V1.0.4	2019-Apr-30	<ul style="list-style-type: none"> <li>Added trigger latency, jitter, and propagation delay information</li> <li>Corrected error in firmware update chapter</li> </ul>
V1.0.3	2019-Mar-08	<ul style="list-style-type: none"> <li>Added Supplier Declaration of Conformity to Compliance and intended use chapter</li> <li>Added EMC compliance statement to Installation and hardware chapter</li> <li>Editorial changes</li> <li>Various improvements and typographic corrections</li> </ul>
V1.0.2	2018-Sep-20	<ul style="list-style-type: none"> <li>Updated technical drawings to identify the 1/4-20 tripod mount</li> <li>Added heavy lens load test criteria under Shock and Vibration</li> </ul>
V1.0.1	2018-Jul-10	<ul style="list-style-type: none"> <li>Updated RoHS statement to include amendment 2015/863/EU</li> <li>Various minor corrections and enhancements</li> </ul>
V1.0.0	2018-May-31	<ul style="list-style-type: none"> <li>New manual release status</li> </ul>

*Table 2: Document history*

# Manual conventions

To give this manual an easily understood layout and to emphasize important information, the following typographical styles and symbols that are used.

## Typographic styles

Style (example)	Function
<b>Emphasis</b>	Programs, or highlighting important things.
Feature names	GigE features names are displayed as monospaced text.
<i>Feature options</i>	Features options and register's options that are selectable by the user are displayed as monospaced italicized text.
<b>UI Element</b>	Text that is displayed, or output, by the system for the user, like parts of the GUI, dialog boxes, buttons, menus, important information, windows titles.
<a href="#">Web Reference</a>	References to other documents or webpages, like web links, hypertext links, emails, but also cross references, that include a link the user can follow by clicking.

Table 3: Typographic styles

## Symbols and notes



### CAUTION

#### Risk of burns

Precautions are described



### CAUTION

#### Injury by falling cameras or lenses

Precautions are described



### CAUTION

#### Risk of cuts by sharp edges of lens mounts

Precautions are described



### NOTICE

#### Material damage

Precautions are described.



### NOTICE

#### **Material damage by electrostatic discharge (ESD)**

Precautions as described.



#### **Avoiding malfunctions**

Precautions are described.



#### **Practical tip**

Additional information helps to understand or ease handling the camera.



#### **Additional information**

Web address or reference to an external source with more information is shown.

## Acronyms and terms

The following table provides a list of abbreviations and acronyms used in this document.

Acronym or term	Description
ADC	Analog-to-digital converter
AIA	Automated Imaging Association
CMOS	Complementary metal-oxide semiconductor
EMVA	European Machine Vision Association
ESD	Electrostatic discharge
FIFO	First-in first-out
GND	Ground (power)
GPO	General purpose output
H × V	Horizontal × Vertical (sensor resolution measurement)
I/O	Input/Output
JIIA	Japan Industrial Imaging Association
LUT	Look-up table
MSDS	Material safety data sheet
NIR	Near Infrared
PA	Planarity adjusted

Table 4: Acronyms and terms used in this document (sheet 1 of 2)

Acronym or term	Description
PoCXP	Power over CoaXPress
QE	Quantum efficiency
ROI	Region of interest
SDK	Software Development Kit
SFNC	Standard Feature Naming Convention

*Table 4: Acronyms and terms used in this document (sheet 2 of 2)*



# Compliance, safety, and intended use



This chapter includes:

- Compliance notifications
- Information about intended use of the camera
- Copyright and trademark statement
- Your safety
- Product safety

## Compliance notifications

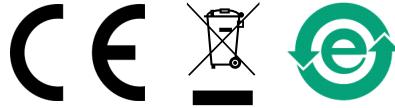

### For customers in the US



#### Class B digital device

Note: This equipment has been tested and found to comply with the limits for a Class B digital device, pursuant to part 15 of the FCC Rules. These limits are designed to provide reasonable protection against harmful interference in a residential installation. This equipment generates, uses and can radiate radio frequency energy and, if not installed and used in accordance with the instructions, may cause harmful interference to radio communications. However, there is no guarantee that interference will not occur in a particular installation. If this equipment does cause harmful interference to radio or television reception, which can be determined by turning the equipment off and on, the user is encouraged to try to correct the interference by one or more of the following measures:

- Reorient or relocate the receiving antenna.
- Increase the separation between the equipment and receiver.
- Connect the equipment into an outlet on a circuit different from that to which the receiver is connected.
- Consult the dealer or an experienced radio or TV technician for help.

We caution the user that changes or modifications not expressly approved by the party responsible for compliance could void the user's authority to operate the equipment.

### Supplier Declaration of Conformity

Bonito PRO cameras comply with Part 15 of the FCC Rules. Operation is subject to the following two conditions:

1. This device may not cause harmful interference, and
2. This device must accept any interference received, including interference that may cause undesired operation.

## Party issuing Supplier's Declaration of Conformity

Allied Vision Technologies GmbH  
Taschenweg 2a  
07646 Stadtroda, Germany  
T// +49 (36428) 677-106  
quality@alliedvision.com

## Responsible party - US contact information

Allied Vision Technologies, Inc.  
102 Pickering Way – Suite 502  
Exton, PA 19341, USA  
T// +1 978 225 2030

**Note:** changes or modifications not expressly approved by the party responsible for compliance could void the user's authority to operate the equipment.

## For customers in Canada

This apparatus complies with the Class A limits for radio noise emissions set out in the Radio Interference Regulations.

CAN ICES-3 (B) / NMB-3 (B)

## Pour utilisateurs au Canada

Cet appareil est conforme aux normes classe A pour bruits radioélectriques, spécifiées dans le Règlement sur le brouillage radioélectrique.

CAN ICES-3 (B) / NMB-3 (B)

## Avoid electromagnetic interferences

For all power and interface connections, only use shielded cables or cables recommended by Allied Vision.

## Intended use

Allied Vision's objective is the development, design, production, maintenance, servicing and distribution of digital cameras and components for image processing. We are offering standard products as well as customized solutions.

Intended use of Allied Vision product is the integration into Vision systems by professionals. All Allied Vision product is sold in a B2B setting.

Allied Vision isn't a legal manufacturer of medical product. Instead, Allied Vision cameras and accessories may be used as components for medical product after design-in by the medical device manufacturer and based on a quality assurance agreement (QAA) between Allied Vision (supplier) and medical device manufacturer (customer). Allied Vision's duties in that respect are defined by ISO 13485, clause 7.2 (customer-related processes, equivalent to ISO 9001, clause 8.2).

## Copyright and trademarks

All text, pictures, and graphics are protected by copyright and other laws protecting intellectual property. All content is subject to change without notice.

All trademarks, logos, and brands cited in this document are property and/or copyright material of their respective owners. Use of these trademarks, logos, and brands does not imply endorsement.

Copyright © 2020 Allied Vision GmbH. All rights reserved.

## Your safety

This section informs about issues related to your personal safety. Descriptions explain how to avoid hazards and operate Bonito PRO cameras safely.

### Handling lens mounts

The lens mount thread has sharp edges. Be careful these edges do not cut your skin when mounting or unmounting lenses.

### Handling hot cameras

If you hold the camera in your hands during operation, your skin may get hurt. If you touch the camera when it is heated up, we recommend wearing protective gloves.

### Providing optimum heat dissipation

Operation outside the allowed temperature range can damage the camera. For best performance and to protect the camera from damage, keep the housing temperature in the specified operating temperature range.

Observe the following:

- To avoid camera crashes, operate the camera with a lens or lens adapter attached only.
- For maximum heat dissipation, affix the camera to a heat sink, using the mounting holes.
- Use mounting base and heat sink with large surface areas.
- Use a mounting base with a high thermal conductivity.
- Reduce ambient temperature. For example, in an outdoor application with direct sunlight, provide shading by an enclosure.
- Provide ventilation or other active cooling of camera, mounting base, and heat sink.

## Camera mounting

Bonito PRO cameras must be mounted using the mounting threads. If vibration is higher than specified, cameras can disconnect from the mounting. Falling cameras can hurt you. To avoid personal injury:

- Mount the camera according to the instructions in the installation chapter.
- Ensure, shock and vibration do not exceed the specified range as specified in the specifications chapter.
- For heavy or long lenses, use a lens support and apply tests.

## Lens load

Many of the lens mount styles available such as M42-Mount, F-Mount, and EF-Mount are not designed for high vibration environments with a heavy lens load. We recommend supporting the lens externally in these environments.

# Product safety

To prevent material damage, read the following to understand how to safely handle and operate the camera.

## Electrical connections

### ESD

ESD is dangerous for electronic devices, especially when tools or hands get in contact with connectors. We recommend measures to avoid damage by ESD:

- Unpacking: Remove the camera from its anti-static packaging only when your body is grounded.
- Workplace: Use a static-safe workplace with static-dissipative mat and air ionization.
- Wrist strap: Wear a static-dissipative wrist strap to ground your body.
- Clothing: Wear ESD-protective clothing. Keep components away from your body and clothing. Even if you are wearing a wrist strap, your body is grounded but your clothes are not.

### Cable connections

Provide sufficient strain relief for all cable connections to avoid short circuits and malfunctions.

### Camera power

Don't operate the camera beyond the environmental specifications. See environmental specifications limits in the Specifications section of this document. Special care must be taken to maintain an operating temperature as specified in the Specifications chapter.

Operating cameras beyond the specified range damages cameras. The camera is not intended to be connected to a DC distribution network.

## Optical components

Provide the following conditions to keep dirt and droplets out of the optical system of camera and lens:

- Dust-free environment
- Low relative humidity
- No condensation.

When camera or lens are stored:

- Cover the lens mount with a protection foil or cap.
- Cover front and back lens with caps.

## Sensor

Sensors are sensitive to excessive radiation: focused sunlight, lasers, and X-rays can damage the sensor. Dirt and scratches can damage the sensor as well.

Bonito PRO cameras do not need additional cleaning. Cameras are cleaned before shipping. Incorrect cleaning can damage the sensor or the filter. Therefore, never clean the sensor or the filter.

Protect the camera filter and the sensor from dirt, because dirt becomes more visible the closer it gets to the sensor. In addition, keep the back lens clean. Hold the camera with the lens mount facing the ground to keep dirt out of the lens mount.

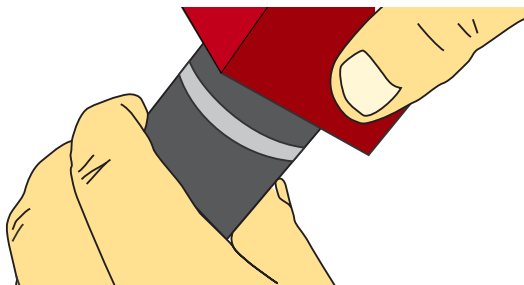

*Figure 1: Holding the camera with the lens mount facing the ground*

## Lenses

### Maximum protrusion

The sensor, filter, lens, or camera electronics can be damaged if a lens exceeding maximum protrusion is mounted to the camera. Use lenses with a maximum protrusion within camera specifications.



# Installing the camera



This chapter describes the components required for your vision system including configuring the host computer, frame grabber settings, and connecting your Bonito PRO camera.

## Touching hot cameras



### CAUTION

#### Risk of burns

A camera in operation can reach temperature levels which could cause burns.

- Wear protective gloves when you touch a camera that is heated up.
- Ensure proper cooling of the camera.

## Electrostatic discharge



### NOTICE

ESD is dangerous for electronic devices, especially when tools or hands get in contact with connectors. We recommend measures to avoid damage by ESD:

- Unpacking: Remove the camera from its anti-static packaging only when your body is grounded.
- Workplace: Use a static-safe workplace with static-dissipative mat and air ionization.
- Wrist strap: Wear a static-dissipative wrist strap to ground your body.
- Clothing: Wear ESD-protective clothing. Keep components away from your body and clothing. Even if you are wearing a wrist strap, your body is grounded but your clothes are not.

# Frame grabbers



### NOTICE

This installation chapter assumes that you have installed a CoaXPress frame grabber in your computer including the related software.

## Recommended frame grabbers

Model tested	Remarks
Euresys Coaxlink Quad G3	PCIe 3.0 four-connection CoaXPress frame grabber, four CoaXPress CXP-6 connections, 2,500 MBps camera bandwidth, PCIe 3.0 (Gen 3) x 4 bus, 3,300 MBps bus bandwidth, PoCXP, Windows drivers
Active Silicon FireBird Quad CXP-6	Quad input CoaXPress frame grabber, four CoaXPress connections each at 6.25 Gbps, Windows support (32-bit and 64-bit), PoCXP

Table 5: Recommended frame grabbers



Not all frame grabbers support all Bonito PRO features.



For a complete list of supported frame grabbers including limitations, see the Hardware Selection for Bonito PRO Cameras application note.

[www.alliedvision.com/en/support/technical-papers-knowledge-base.html](http://www.alliedvision.com/en/support/technical-papers-knowledge-base.html)



Contact your Allied Vision Sales representative or your local Allied Vision distribution partner for lens recommendations:

[www.alliedvision.com/en/meta-header/contact/contact-sales](http://www.alliedvision.com/en/meta-header/contact/contact-sales)



The Euresys Coaxlink Quad G3 frame grabber and GenICam browser were used to create the screenshots in this document.

# Mounting the camera



## CAUTION

### Injury by falling cameras or lenses

A falling camera or lens can cause injury.

- Ensure proper mounting of cameras and lenses, especially for dynamic applications.
- Mount cameras as described in the instructions.
- Use a lens support for heavy lenses.

You can attach the camera to a base using the M3 thread mounting holes built into the top, bottom, sides, and front of the Bonito PRO camera housing and lens mount. Bonito PRO cameras also have a built-in 1/4-20 tripod mounting hole on two sides.

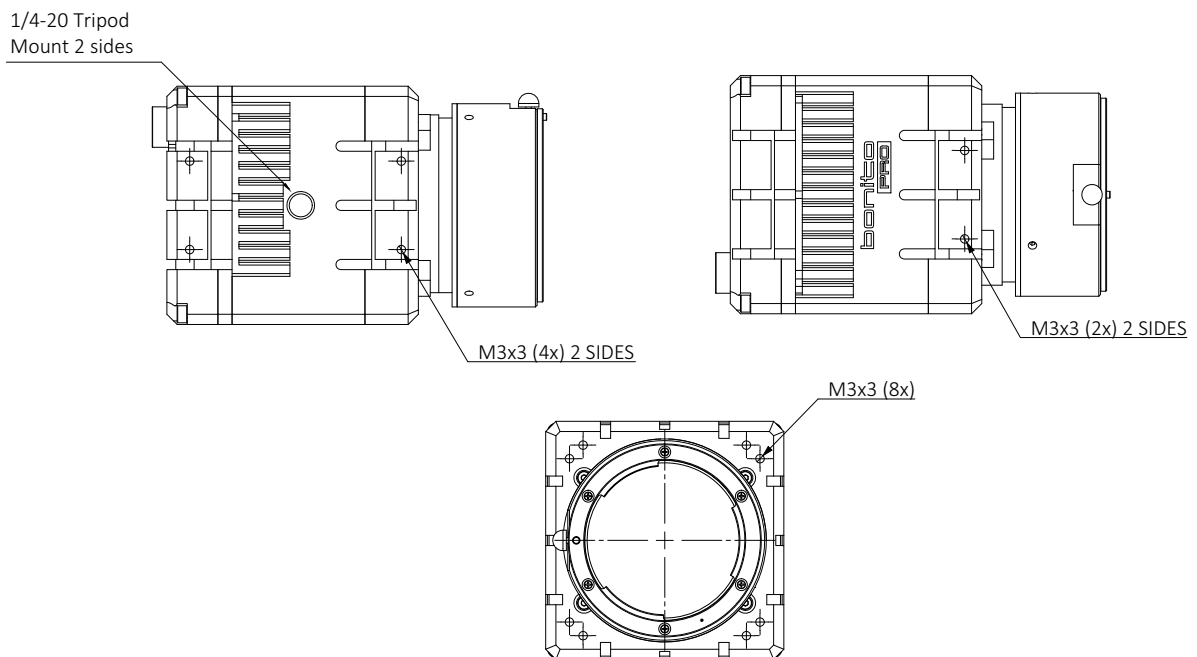

Figure 2: Mounting holes in top, bottom, and sides of camera

**NOTICE**

Please observe the following when mounting the camera:

- It is important to consider the maximum intrusion depth of the M3 mounting holes. Using longer screws can damage the threads or bottom plate and will reduce the strength of the joint.
- Use a spacer, spring lock washer, or internal tooth lock washer to reduce the intrusion depth of longer screws.
- Apply low-strength thread-locking fluid to the screws to prevent loosening of the screws under vibrational loading.

## Mounting the lens

**CAUTION**
**Injury by falling cameras or lenses**

A falling camera or lens can cause injury.

- Ensure proper mounting of cameras and lenses, especially for dynamic applications.
- Mount cameras as described in the instructions.
- Use a lens support for heavy lenses.

**CAUTION**
**Risk of cuts by sharp edges of lens mounts**

The threads of the lens mount can have sharp edges.

Be careful when mounting or unmounting lenses.

**NOTICE**

Many of the lens mount styles available such as M42-Mount, F-Mount, and EF-Mount are not designed for high vibration environments with a heavy lens load. We recommend supporting the lens externally in these environments.

**NOTICE**

As monochrome and NIR models don't have an optical filter, always attach a dust cap when a lens is not attached to minimize the possibility of contaminants falling on the sensor surface.

**NOTICE**

Provide the following conditions to keep dirt and droplets out of the optical system of camera and lens:

- Dust-free environment
- Low relative humidity
- No condensation

To keep dirt out of the lens mount, hold the camera with the lens mount facing the ground. Keep filter and camera back lens clean, because dirt becomes more visible the closer it gets to the sensor.

**NOTICE**

Image sensors are sensitive to excessive radiation: focused sunlight, lasers, and X-rays can damage the sensor.

Bonito PRO cameras offer various lens mounts for installing a lens including F-Mount, F-Mount PA, M42-Mount, M42-Mount PA, M58-Mount PA, M58-Mount PA, and Canon EF-Mount PA. Lenses can be purchased directly from Allied Vision or from an Allied Vision distribution partner. Users need to select the desired focal length of the lens and appropriate optical format for the target camera model.

For more information on lens mount options for your Bonito PRO camera, see the Modular Concept. For information on available lenses and accessories for your camera, see the Accessories webpage.

## Planarity mounts

**NOTICE**

Modifying the factory default adjustment is under the responsibility of the user. Exercise caution when modifying the planarity adjustment. Use a 1.5 mm hex ball driver to loosen the three spring loaded screws, adjust the tilt adjustment screws as required, then secure the screws.

## Cameras and lens load

We tested a Bonito PRO X-1250B with an EF-Mount PA and a Bonito PRO X-1250B NIR with an F-Mount (non-PA).

### Lens simulators

Lens simulators were used to simulate lenses.

Feature	Properties
General description	The lens simulators were made from aluminum.
Length	43 mm, from the lens mount front flange to the front face of the lens simulator.
Center of gravity	20.4 mm, out from the lens mount front flange along the z-axis.
Mass	Approximately 517 grams each.

*Table 6: Lens simulators properties*



#### NOTICE

If lenses or stress exceeds the range tested

- For heavier or longer lenses, support both the camera and lens.
- Apply additional tests.

## Powering the camera

A camera power adapter for each Bonito PRO camera is available from Allied Vision. See the Specifications chapter for connector definition and voltage specifications.



#### NOTICE

Bonito PRO cameras are powered via the Hirose connector or Power over CoaXPress (PoCXP). PoCXP is implemented for each CoaXPress connector using a host transceiver. When PoCXP is enabled, the host shall supply 24 VDC  $\pm$  2.4 V to the CoaXPress connector. The host should be capable of supplying 13 W per cable over the full voltage range.

**NOTICE**

When powering the camera:

- Use only DC power supplies with insulated cases.
- Do not exceed the wattage as specified in the Specifications chapter.
- For all power connections use only shielded cables to avoid electromagnetic interference.
- Bonito PRO cameras can be powered from either the Hirose I/O port or via PoCXP. Power supplied via Hirose I/O takes priority over power supplied via PoCXP.
- When powering the camera via the Hirose I/O port, use a power supply recommended by Allied Vision

**NOTICE**

The camera is not intended to be connected to a DC distribution network. The maximum length for I/O cables must not exceed 30 meters.

**NOTICE**

Verify all external connections in terms of voltage levels, power requirements, voltage polarity, and signal integrity prior to powering the device.

**NOTICE**

Heat can cause damage to the camera. Operation outside the specified temperature range can damage the camera. For best performance and to protect the camera from damage, keep the housing temperature between the specified operating temperature.

Observe the following:

- Keep the camera passive cooling fins free of dust and other contaminants.
- For maximum heat dissipation, affix the camera to a heat sink, using the mounting threads.
  - Use mounting base and heat sink with large surface areas.
  - Use a mounting base with a high thermal conductivity.
- Reduce ambient temperature. For example, in an outdoor application with direct sunlight, provide shading by an enclosure.
- Provide ventilation or other active cooling of camera, mounting base, and heat sink.

## CXP-6

Bonito PRO cameras stream images at CXP-6 speeds with four connections only.



## PoCXP

A frame grabber that supports PoCXP is required providing the camera with required power as per the specifications. Each connection supports up to 13 watts.

## Line1 is master

- When connecting the camera to power always connect Line1 last.
- Some frame grabbers require that the master connection is always on line 1 and line 1 is connected to line 1 on the frame grabber.
- As power is provided by all lines, you must disconnect all four cables to power cycle the camera.

## Connecting your camera



CoaXPress uses 75 ohm coaxial cable as a physical medium.



The maximum cable length between the Bonito PRO camera and the host computer is dependent on the bit rate and the type of coax cable used. For more information refer to the J11A CoaXPress Standard Version 1.1.1.

The procedure to obtain the first image from your Bonito PRO camera is dependent on the frame grabber GenICam browser or SDK. The Euresys Coaxlink Quad G3 CXP-6 frame grabber GenICam browser was used to create the screen shots in this document. These screen shots are not representative of every frame grabber GenICam browser.

Follow the steps to connect your camera and obtain the first image:

1. Install the frame grabber in your host computer and configure the frame grabber software including drivers, utilities, and libraries. Ensure the system BIOS version is compatible with the frame grabber. For additional information, see the frame grabber quick start guide or other documentation provided by the manufacturer.
2. Connect your Bonito PRO camera to your frame grabber via four 75 ohm coaxial cables.
3. The camera can be powered via the Hirose I/O port using a compatible power supply or it can be powered via a PoCXP frame grabber.
4. Mount a lens to the camera.

5. Start the frame grabber GenICam browser and wait for the camera to be discovered. When discovered, the Bonito PRO camera is listed under **Remote Devices**.

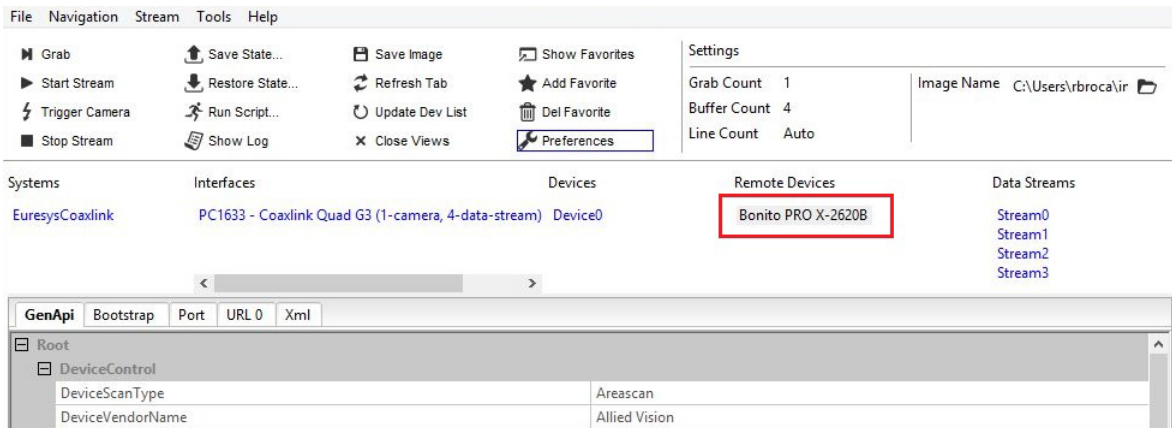

Figure 3: Camera is listed under Remote Devices

6. Double-click the camera name and then click the **GenApi** tab.

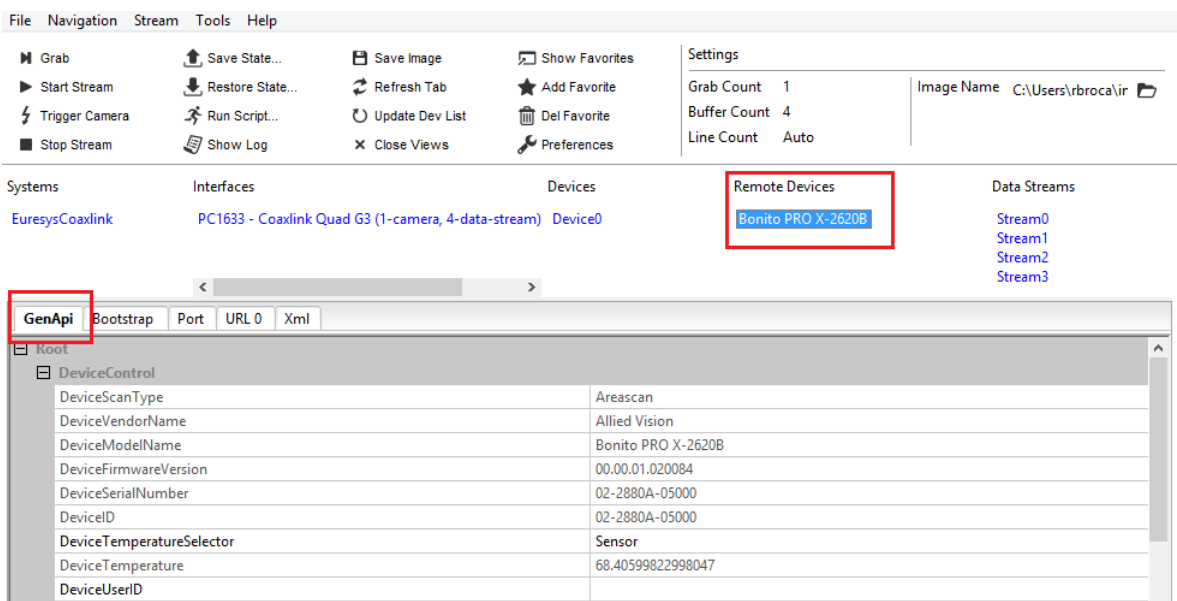

Figure 4: Double-click the camera and GenApi tab

7. Configure camera settings as required.
8. Click the **Start Stream** button to start streaming images.
9. Click the **Stop Stream** button to stop streaming images.

## Accessories

Allied Vision offers a wide range of accessories for the use of Bonito PRO CXP-6 cameras and the easy integration in already existing applications including:

- CXP-6 cables
- Lenses for corresponding sensor sizes and resolutions

Contact your Allied Vision Sales team or your local Allied Vision distribution partner for information on accessories and lens recommendations.

A list of recommended accessories is available on the Allied Vision website. For supported frame grabbers, see the Hardware Selection for Bonito PRO Cameras application note

# Specifications



This chapter provides:

- Applied standards
- Technical specifications
- Absolute QE plots
- Spectral response plots
- Resolution and ROI frame rates
- Feature availability in Bonito PRO camera models

## Applied standards

### JIIA CoaXPress

The JIIA is the Japanese machine vision standards body. The JIIA CoaXPress Technical Committee is responsible for the preparation and maintenance of the CoaXPress Standard.

### GenICam™

GenICam is a machine vision standard hosted by the EMVA. The aim of GenICam is to provide a generic configuration interface for cameras and devices independent of the used interface technology. This approach enables proper interoperability between GenICam compliant hardware and software solutions without the need for customization.

The GenICam standard consists of multiple modules that specify tasks to be solved. Allied Vision cameras and software make use of these modules, like the SFNC that standardizes feature names and types via an XML file or the transport layer interface (GenTL) that is used to grab images.

## Shock and vibration

Cameras were successfully tested for compliance with:

- IEC 60068-2-6, Sinusoidal vibration testing
- IEC 60068-2-27, Non-repetitive shock testing
- IEC 60068-2-27, Repetitive shock testing
- IEC 60068-2-64, Random vibration testing

If you need more details, please contact [support@alliedvision.com](mailto:support@alliedvision.com).

# Notes on specifications

## Dimensions and mass

Dimensions include connectors and default lens mount (F-Mount) but not the tripod and lens.

Mass does not include the tripod and lens.

Both dimensions and mass values in the specification tables are for the default configuration of the camera (default housing and lens mount).

## Modular options

Bonito PRO cameras can be ordered with several modular options including lens mount and optical filter options. For more information, see the Modular Concept.

## Resolution and ROI frame rates

Resolution and ROI frame rates are listed after the specification table. This table includes the resulting frame rate from changing sensor height from full image to 16 lines. Unless otherwise noted, sensors do not give an increase in readout speed with a reduction in width. However, in cases where a camera is limited by frame rate due to bandwidth restrictions, a reduction in width gives a frame rate increase.



### Frame rates and readout

Although the sensor is capable of higher frame rates, readout is limited by bandwidth and exposure value. You can improve frame rates with a reduced region of interest and shorter exposure values.

## Absolute QE plots

All measurements were done without protection glass or IR cut filter. With protection glass or filters, QE decreases by approximately 10 percent.

The uncertainty in measurement of the QE values is  $\pm 10$  percent. This is mainly due to uncertainties in the measuring apparatus itself (Ulbricht sphere, optometer). Manufacturing tolerance of the sensor increases overall uncertainty.

## ON Semi sensors

The curve in the absolute QE plots shown in this chapter is taken from the sensor manufacturer data sheet.

The information was correct at the time of publishing.

## Spectral response plots

The curves in the spectral response plots shown in this chapter were calculated using the absolute QE taken from the sensor data sheet.

# Specifications common to all models

The following table provides specifications common to all Bonito PRO models.

Feature	Specification
Shutter mode	Global shutter
Default lens mount	F-Mount
Optional lens mounts	<ul style="list-style-type: none"> <li>• EF-Mount PA</li> <li>• F-Mount PA</li> <li>• M42-Mount</li> <li>• M42-Mount PA</li> <li>• M58-Mount</li> <li>• M58-Mount PA</li> </ul>
Default optical filter	<ul style="list-style-type: none"> <li>• Monochrome and NIR models: No optical filter</li> <li>• Color models: Type IRC30 IR cut filter</li> </ul>
Optional optical filters	<ul style="list-style-type: none"> <li>• Type IRC30 IR cut filter</li> <li>• B 270 ASG protection glass</li> <li>• Type Schneider 486 IR cut filter</li> </ul>
TTL (non-isolated) I/Os	1 input, 2 outputs
Opto-isolated I/Os	1 input, 2 outputs
Voltage requirements	24 VDC $\pm$ 2.4 VDC, PoCXP
Digital interface	CoaXPress (CXP-6), 4 x DIN 1.0/2.3 type connectors 75 ohm coaxial cable; up to 6.25 Gbps data rate per cable
Interface standard	CoaXPress Standard Version 1.1.1
Temperature monitoring	Available for main board and sensor board. Resolution: 0.031; Accuracy: $\pm$ 1 degrees Celsius

*Table 7: Specifications common to all Bonito PRO models (sheet 1 of 2)*

Feature	Specification
Body dimensions (L × W × H)	114.9 × 70 × 70 mm (with F-Mount and connectors)
Mass (typical)	500 g (depending on lens mount type)
Operating temperature	-20 °C to +70 °C housing temperature (without condensation)
Storage temperature	-20 °C to +70 °C ambient temperature (without condensation)
Operating humidity	20 to 80% non-condensing

Table 7: Specifications common to all Bonito PRO models (sheet 2 of 2)

## Trigger jitter, delay, and propagation delay

The following table provides trigger jitter, trigger delay, and propagation delay values for Bonito PRO cameras.

External trigger input	Trigger delay	Trigger jitter
Non-isolated trigger input <sup>1</sup>	200.5 ns	± 6.5 ns
Opto-isolated trigger input <sup>1</sup>	234.5 ns	± 6.5 ns
Opto-isolated propagation delay ( $t_{pd}$ )	34 ns	
With exposure start delay with non-isolated input <sup>2</sup>	9.623 μs	± 7.5 ns
With exposure start delay with opto-isolated input <sup>2</sup>	9.653 μs	± 7 ns

<sup>1</sup> Using a three meter long I/O cable for trigger input adds 20 ns to trigger latency and ± 0.5 ns to trigger jitter.

<sup>2</sup> Exposure start delay is the delay within the image sensor. It is the time between the sensor getting the trigger signal and when it starts the exposure.

Table 8: Trigger jitter, delay, and propagation delay



## Bonito PRO X-1250 series

The following table provides model series specifications. The values are valid for Bonito PRO X-1250B, X-1250B NIR, and X-1250C models. For specifications common to all models, see [Specifications common to all models](#).



### Discontinuation

Due to ON Semi's discontinuation of the PYTHON 12K sensor, the Bonito PRO X-1250 series has been discontinued with the last time buy period ending on October 31, 2020. For more information, see the Product change notice webpage at [www.alliedvision.com/en/support/product-change-notifications](http://www.alliedvision.com/en/support/product-change-notifications).

Feature	Specification	
	Bonito PRO X-1250B, X-1250B NIR	Bonito PRO X-1250C
Sensor model	ON Semi PYTHON 12K (NOIP1SN012KA, NOIP1FN012KA)	ON Semi PYTHON 12K (NOIP1SE012KA)
Resolution (H × V)	4096 × 3072; 12.5 MP	
Sensor type	CMOS	
Sensor format	Type 4/3	
Sensor size	23.04 mm diagonal	
Pixel size	4.5 μm × 4.5 μm	
Maximum frame rate at full resolution	142.6 fps (8-bit) 136.6 (10-bit)	
Maximum image bit depth	10-bit	
Monochrome pixel formats	Mono8, Mono10	Not applicable
RAW pixel formats	Not applicable	BayerRG8, BayerRG10
Exposure control	1 μs to 1 s, 1 μs increments	
Gain control	0 to 22 dB	
Binning	Horizontal: 1, 2, 4, 8 columns Vertical: 1, 2, 4, 8 rows	
Decimation X/Y	Horizontal and vertical: 1, 2, 4, 8 factor	
Power consumption	15.7 W at 24 VDC 15.7 W PoCXP	
Trigger latency	See <a href="#">Trigger jitter, delay, and propagation delay</a>	
Trigger jitter	See <a href="#">Trigger jitter, delay, and propagation delay</a>	
Propagation delay ( $t_{pd}$ )	See <a href="#">Trigger jitter, delay, and propagation delay</a>	

Table 9: Bonito PRO X-1250 model series specifications

## Absolute QE

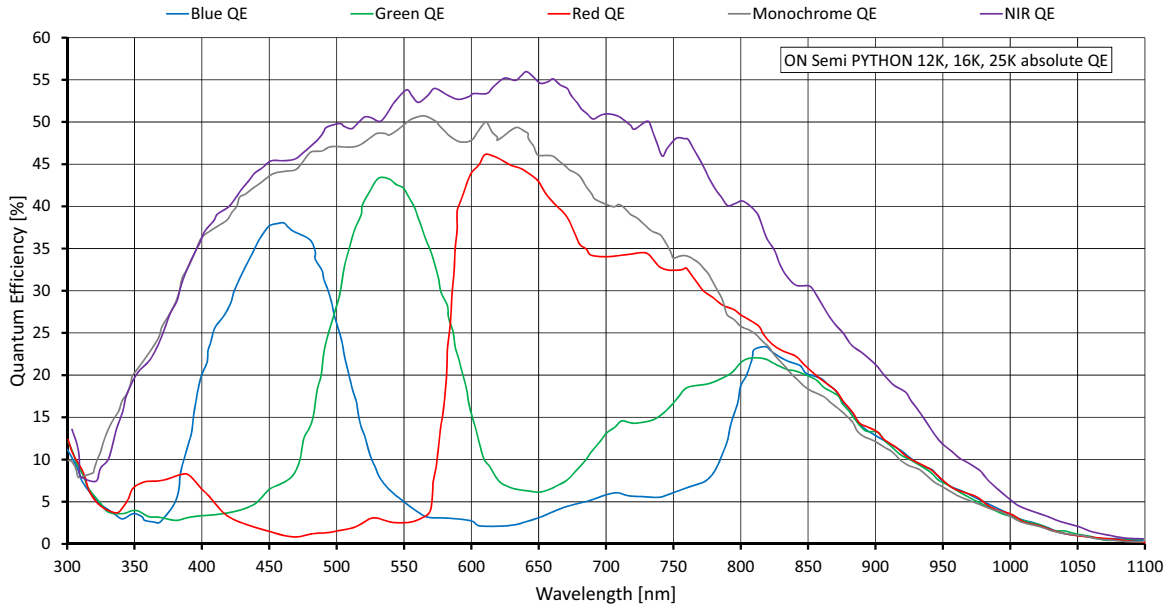

Figure 5: Bonito PRO X-1250 (ON Semi PYTHON12K) absolute QE

## Spectral response

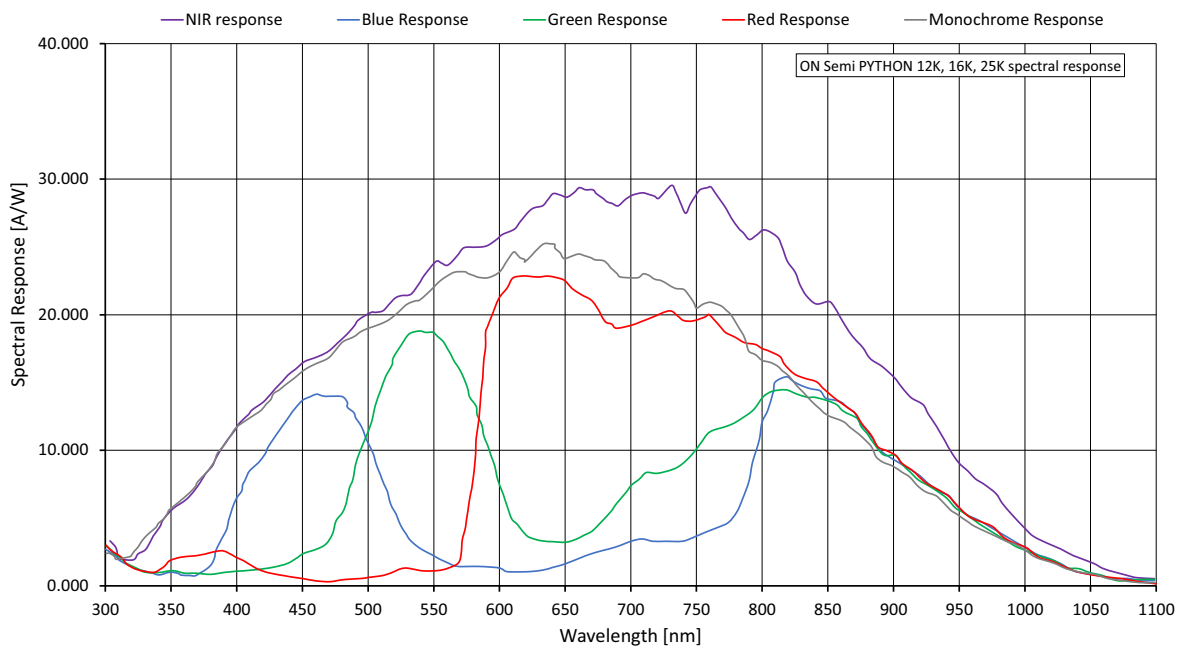

Figure 6: Bonito PRO X-1250 (ON Semi PYTHON12K) spectral response

## ROI frame rates

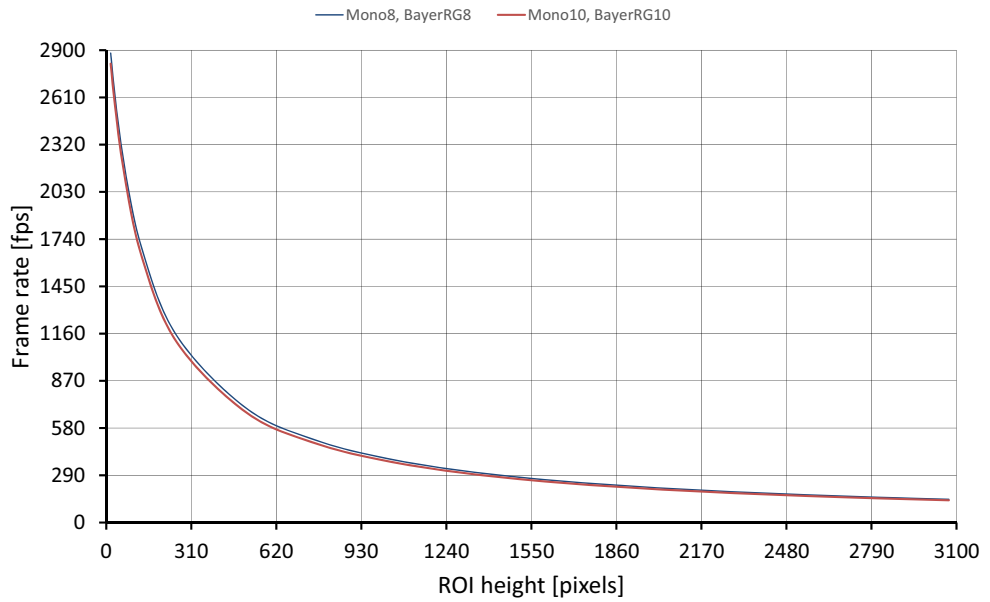

Figure 7: Bonito PRO X-1250 frame rate as a function of ROI height

### 8-bit pixel formats (Mono8, BayerRG8)

Height	Frame rate (fps)	Height	Frame rate (fps)	Height	Frame rate (fps)
3072	142.6	1536	273.0	128	1692.0
2816	154.9	1280	322.2	64	2212.3
2560	169.9	1024	392.9	32	2617.8
2304	187.4	768	503.2	16	2881.8
2048	209.2	512	699.7		
1792	236.9	256	1149.4		

Table 10: Bonito PRO X-1250 frame rate as a function of ROI height (Width=4096 pixels)

### 10-bit pixel formats (Mono10, BayerRG10)

Height	Frame rate (fps)	Height	Frame rate (fps)	Height	Frame rate (fps)
3072	136.6	1536	261.9	128	1639.3
2816	148.5	1280	309.2	64	2155.1
2560	162.6	1024	377.2	32	2557.5
2304	179.6	768	483.5	16	2816.9
2048	200.6	512	673.8		
1792	227.2	256	1109.8		

Table 11: Bonito PRO X-1250 frame rate as a function of ROI height (Width=4096 pixels)

## Bonito PRO X-2620 series

The following table provides model series specifications. The values are valid for Bonito PRO X-2620B, X-2620B NIR, and X-2620C models. For specifications common to all models, see [Specifications common to all models](#).

Feature	Specification	
	Bonito PRO X-2620B, X-2620B NIR	Bonito PRO X-2620C
Sensor model	ON Semi PYTHON 25K (NOIP1SN025KA, NOIP1FN025KA)	ON Semi PYTHON 25K (NOIP1SE025KA)
Resolution (H × V)	5120 × 5120; 26.2 MP	
Sensor type	CMOS	
Sensor format	Type APS-H	
Sensor size	32.6 mm diagonal	
Pixel size	4.5 μm × 4.5 μm	
Maximum frame rate at full resolution	79.7 fps (8-bit) 70.1 fps (10-bit)	
Maximum image bit depth	10-bit	
Monochrome pixel formats	Mono8, Mono10	Not applicable
RAW pixel formats	Not applicable	BayerRG8, BayerRG10
Exposure time control	1 μs to 1 s, 1 μs increments	
Gain control	0 to 22 dB	
Binning	Horizontal: 1, 2, 4, 8 columns Vertical: 1, 2, 4, 8 rows	
Decimation X/Y	Horizontal and vertical: 1, 2, 4, 8 factor	
Power consumption	15.7 W at 24 VDC 15.7 W PoCXP	
Trigger latency	See <a href="#">Trigger jitter, delay, and propagation delay</a>	
Trigger jitter	See <a href="#">Trigger jitter, delay, and propagation delay</a>	
Propagation delay ( $t_{pd}$ )	See <a href="#">Trigger jitter, delay, and propagation delay</a>	

Table 12: Bonito PRO X-2620 model series specifications

## Absolute QE

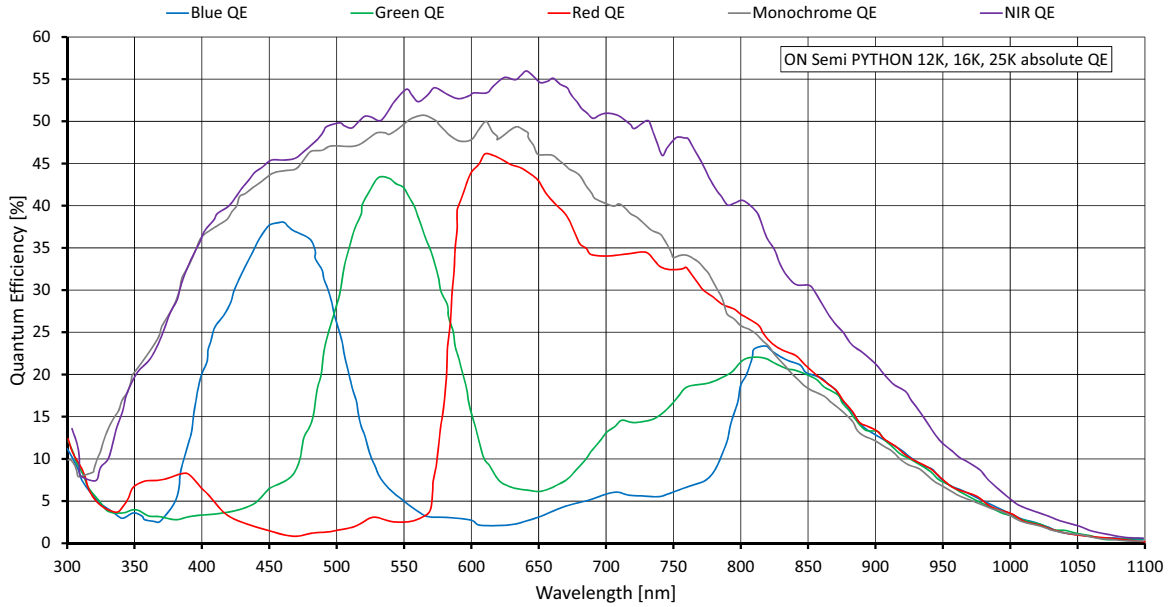

Figure 8: Bonito PRO X-2620 (ON Semi PYTHON 25K) absolute QE

## Spectral response

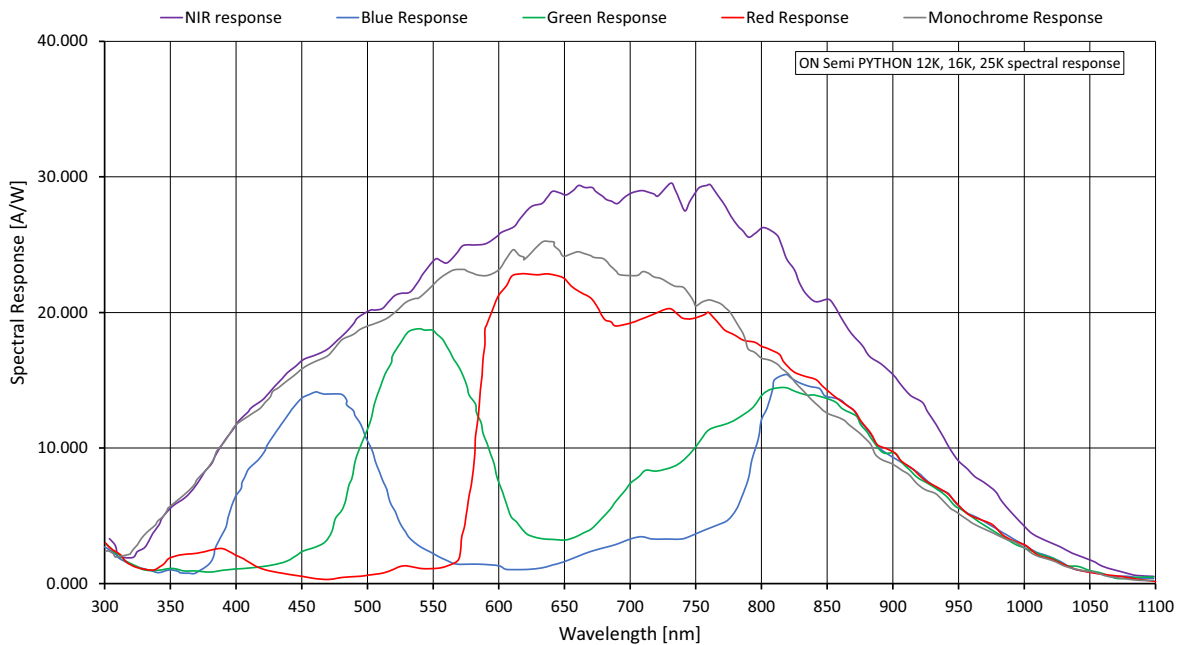

Figure 9: Bonito PRO X-2620 (ON Semi PYTHON 25K) spectral response

## ROI frame rates

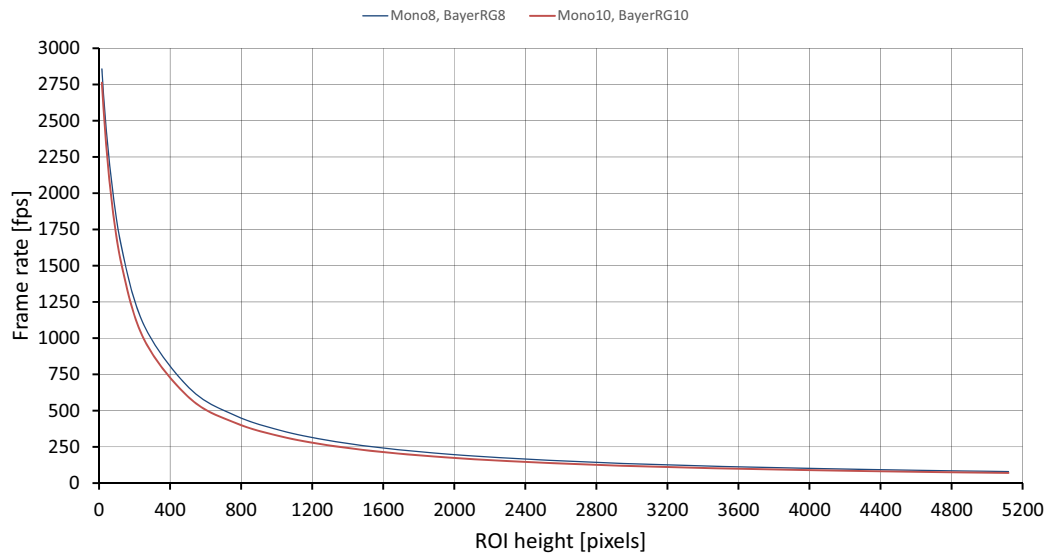

Figure 10: Bonito PRO X-2620 frame rate as a function of ROI height

### 8-bit pixel formats (Mono8, BayerRG8)

Height	Frame rate (fps)	Height	Frame rate (fps)	Height	Frame rate (fps)
5120	79.7	3072	130.7	1024	362.5
4864	83.8	2816	142.0	768	465.7
4608	88.3	2560	155.5	512	651.4
4352	93.3	2304	171.9	256	1082.2
4096	99.0	2048	192.1	128	1618.1
3840	105.4	1792	217.7	64	2150.5
3584	112.4	1536	251.1	32	2570.6
3328	121.0	1280	296.7	16	2857.1

Table 13: Bonito PRO X-2620 frame rate as a function of ROI height (Width=5120 pixels)

### 10-bit pixel formats (Mono10, BayerRG10)

Height	Frame rate (fps)	Height	Frame rate (fps)	Height	Frame rate (fps)
5120	70.1	3072	115.1	1024	321.9
4864	73.7	2816	125.2	768	415.1
4608	77.7	2560	137.2	512	584.1
4352	82.2	2304	151.7	256	985.2
4096	87.1	2048	169.6	128	1499.2
3840	92.8	1792	192.4	64	2023.5
3584	99.2	1536	222.2	32	2469.1
3328	106.6	1280	262.9	16	2762.4

Table 14: Bonito PRO X-2620 frame rate as a function of ROI height (Width=5120 pixels)



## Camera features

Bonito PRO cameras support a number of standard and extended features. The following table identifies a selection of capabilities and compares the availability of features in Bonito PRO camera models.

For a complete description of individual features, see the Bonito PRO Features Reference.

<b>Image optimization features</b>	<b>X-1250</b>	<b>X-2620</b>
Auto gain	✓	✓
Auto exposure	✓	✓
Auto white balance (color models only)	✓	✓
Binning (horizontal and/or vertical), (sum or average)	✓	✓
Black level (offset)	✓	✓
Decimation X/Y	✓	✓
Gamma correction	✓	✓
Three look-up tables	✓	✓
Defect Pixel Correction	✓	✓
Fixed Pattern Noise Correction	✓	✓

*Table 15: Image optimization features by model*

<b>Camera control features</b>	<b>X-1250</b>	<b>X-2620</b>
Multiple regions of interest (Multi-ROI)	✓	✓
Sequencer Control	✓	✓
Trigger over CoaXPress	✓	✓
EF lens control (order option-18)	✓	✓
Storable user sets	✓	✓
Sync out modes: Trigger ready, input, exposing, readout, imaging, strobe, GPO	✓	✓
Temperature monitoring (main board and sensor board)	✓	✓

*Table 16: Camera control features by model*

# Mechanical dimensions

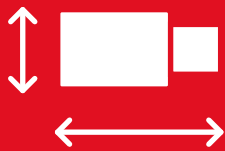

This chapter includes:

- Mechanical drawings and dimensions of Bonito PRO housing and mounts
- Flange focal distance
- Sensor position accuracy

Bonito PRO cameras are available with different lens mount options. For more information, see the Modular Concept.

## Bonito PRO housing and mounts

### F-Mount (default mount)

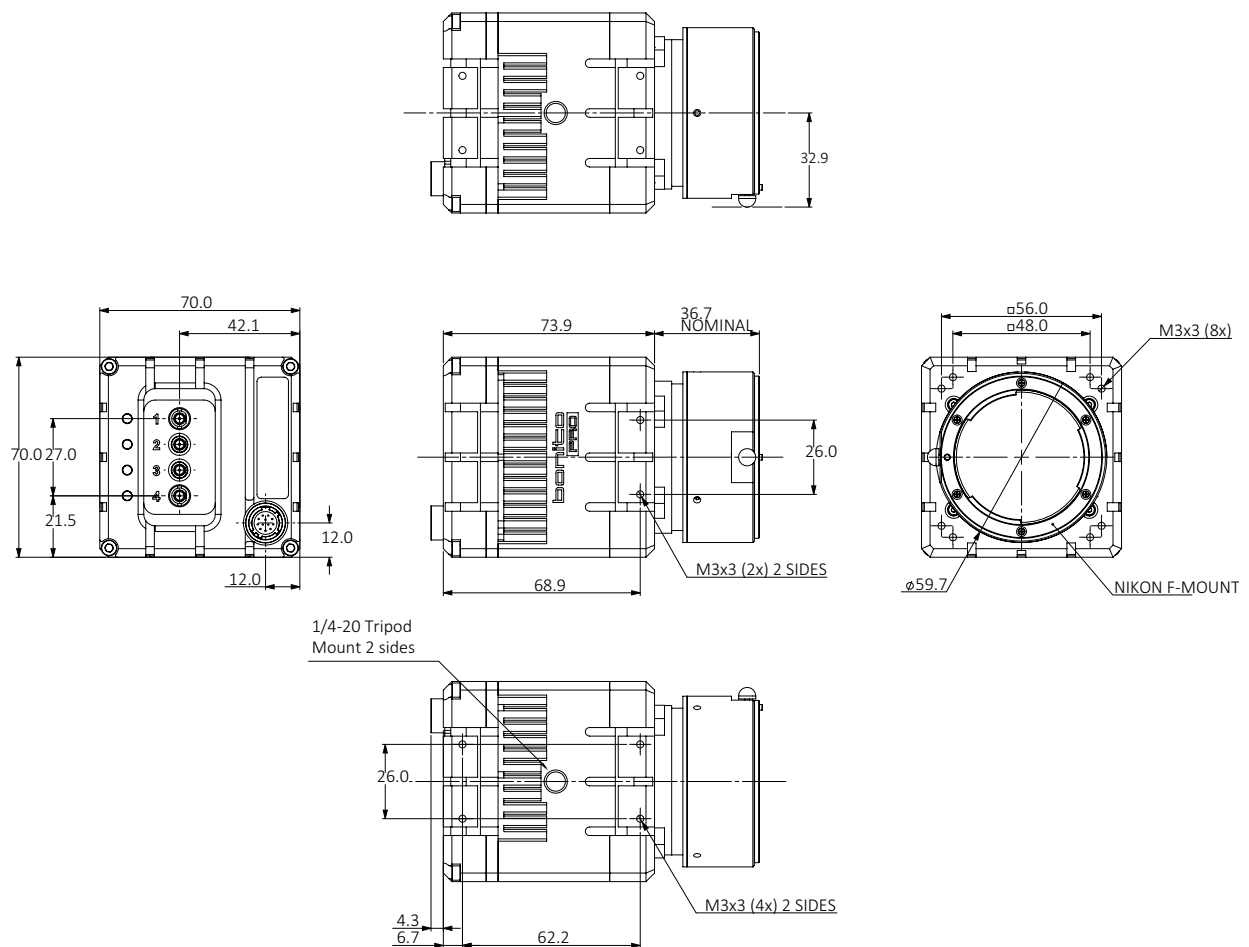

Figure 11: Bonito PRO camera with F-Mount, mechanical dimensions

## F-Mount PA

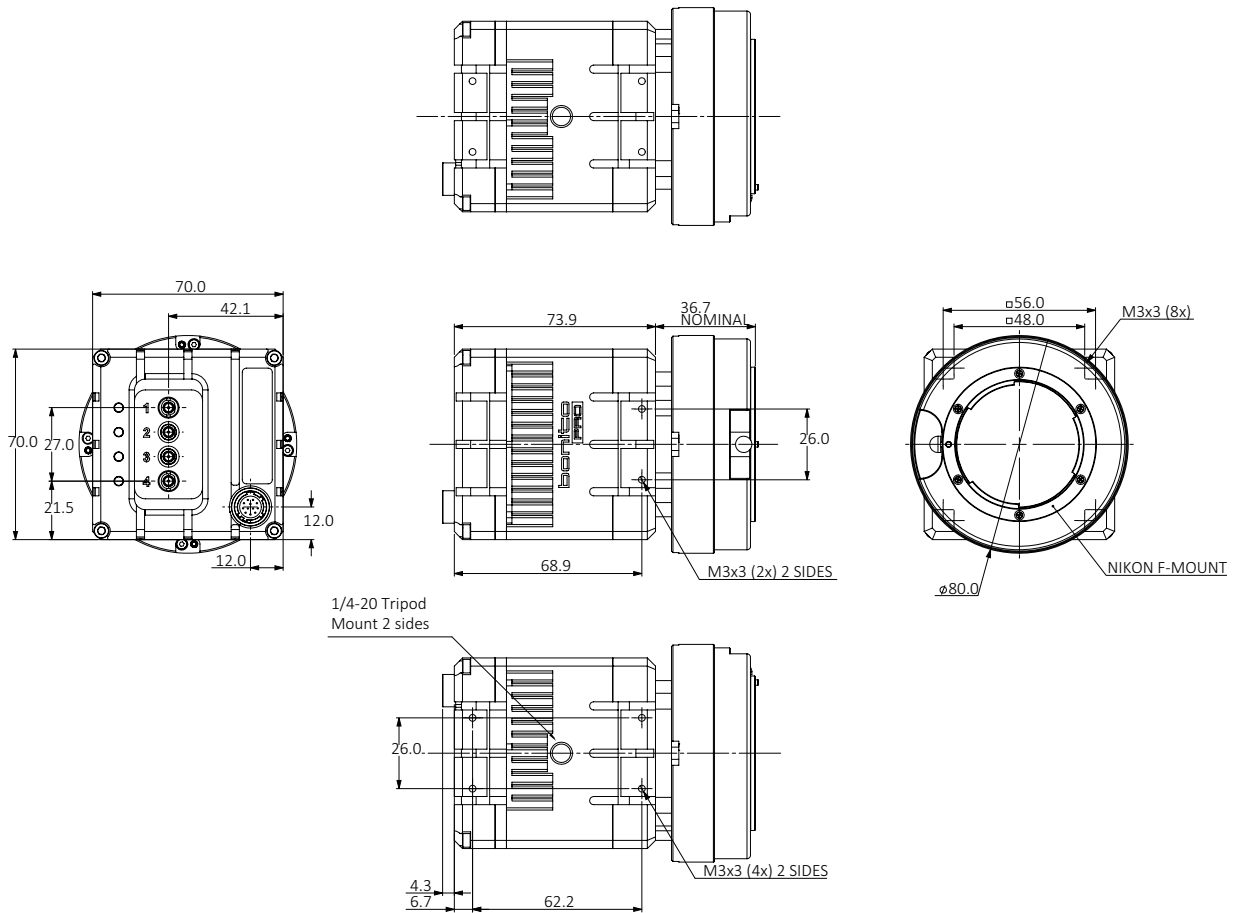

Figure 12: Bonito PRO camera with F-Mount PA, mechanical dimensions



### F-Mount PA order code

Contact the Allied Vision Sales team to purchase the Bonito PRO series camera with F-Mount PA option (order code Bonito PRO...-03).

## EF-Mount PA

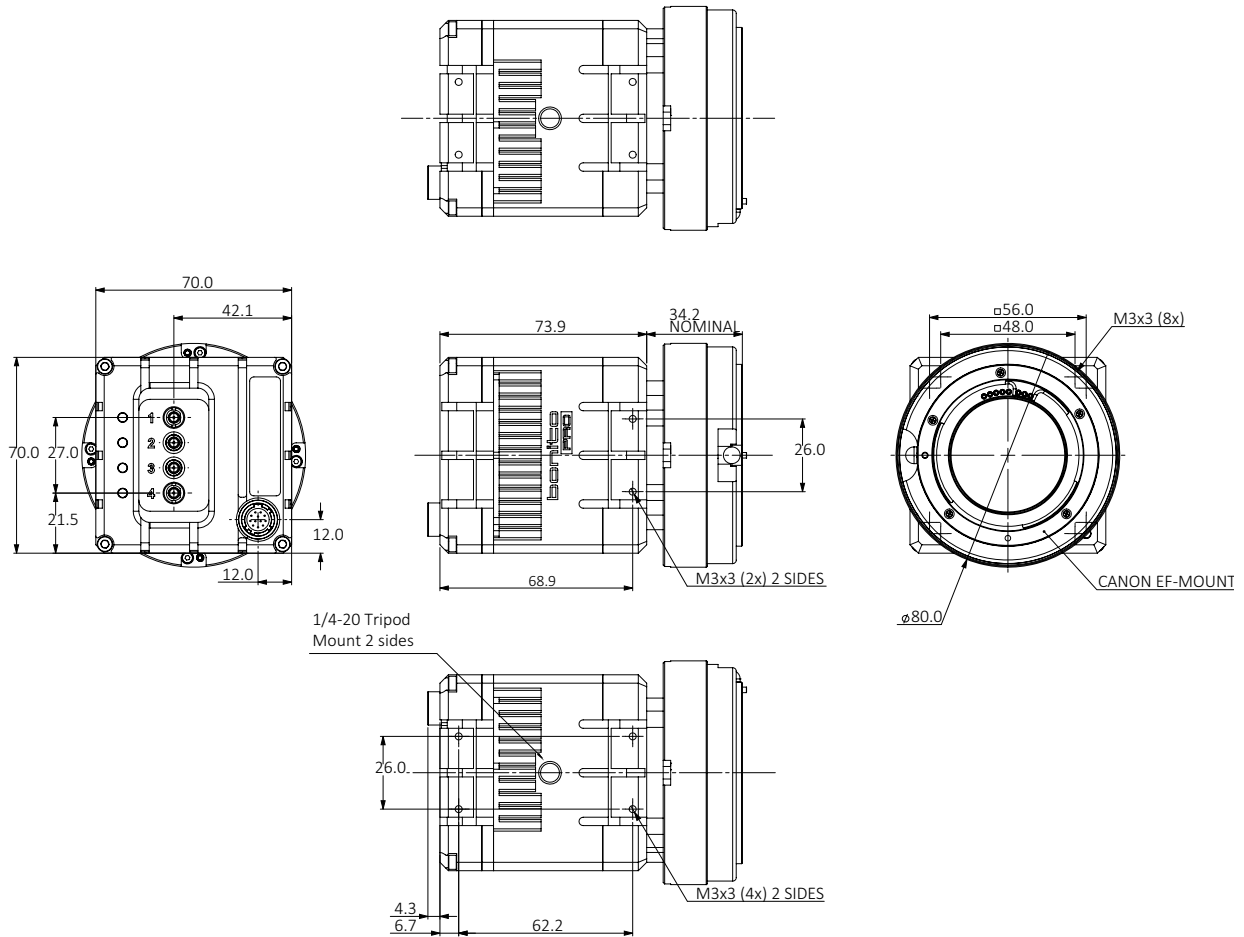

Figure 13: Bonito PRO camera with EF-Mount PA, mechanical dimensions



### EF-Mount PA order code

Contact the Allied Vision Sales team to purchase the Bonito PRO series camera with EF-Mount PA option (order code Bonito PRO...-18).

## M42-Mount

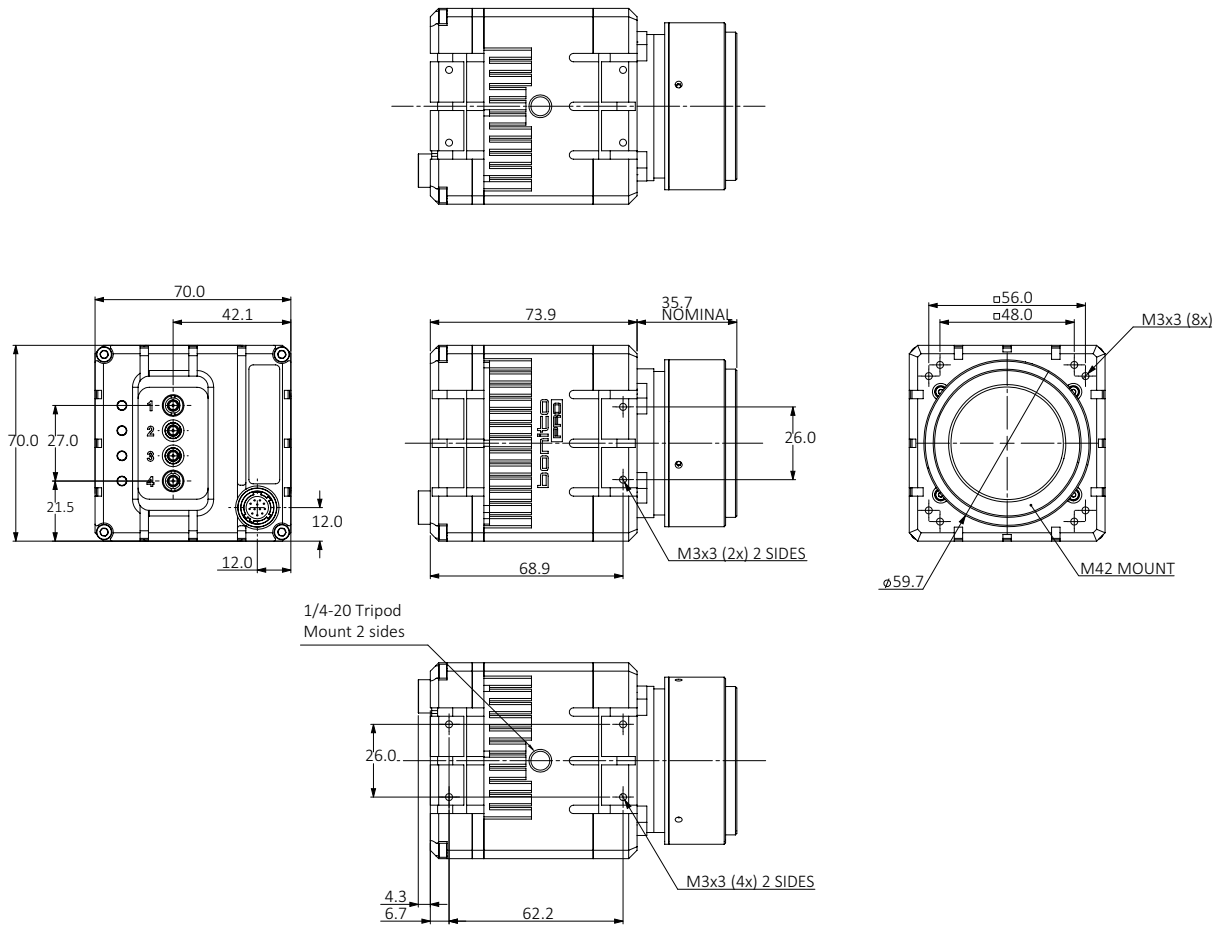

Figure 14: Bonito PRO camera with M42-Mount, mechanical dimensions



### M42-Mount order code

Contact the Allied Vision Sales team to purchase the Bonito PRO series camera with M42-Mount option (order code Bonito PRO...-31).

## M42-Mount PA

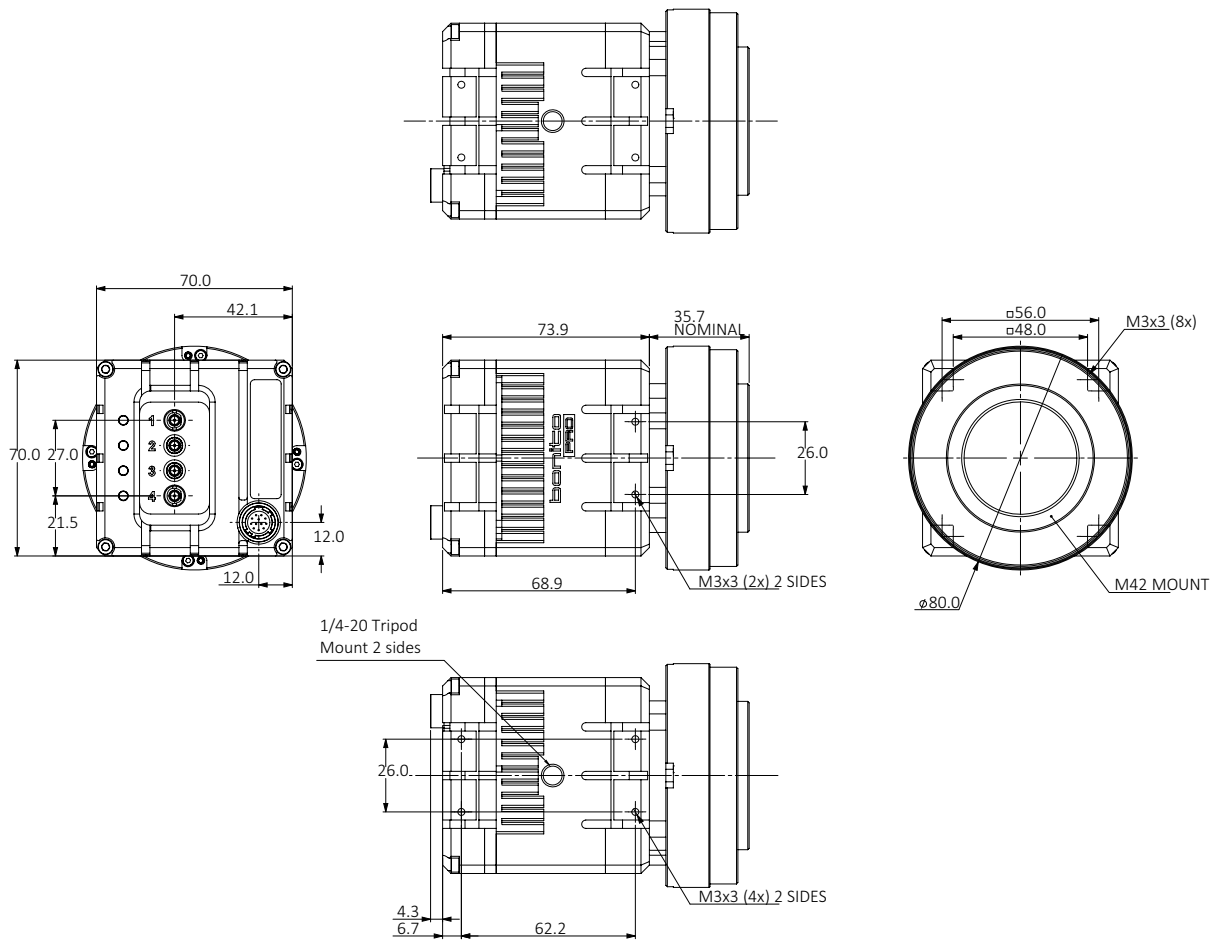

Figure 15: Bonito PRO camera with M42-Mount PA, mechanical dimensions



### M42-Mount PA order code

Contact the Allied Vision Sales team to purchase the Bonito PRO series camera with M42-Mount PA option (order code Bonito PRO...-25).

## M58-Mount

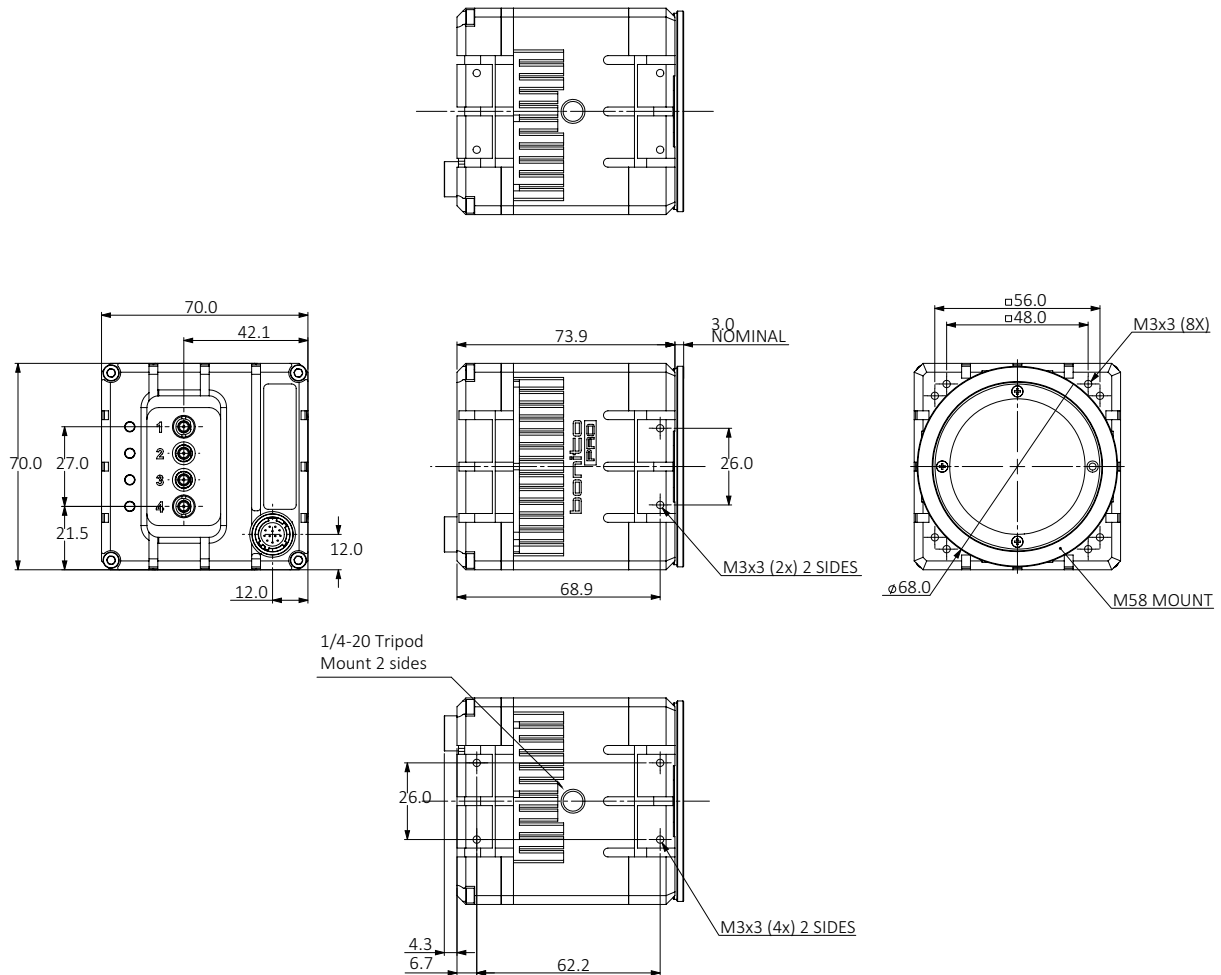

Figure 16: Bonito PRO camera with M58-Mount, mechanical dimensions



### M58-Mount order code

Contact the Allied Vision Sales team to purchase the Bonito PRO series camera with M58-Mount option (order code Bonito PRO...-12).



## M58-Mount PA

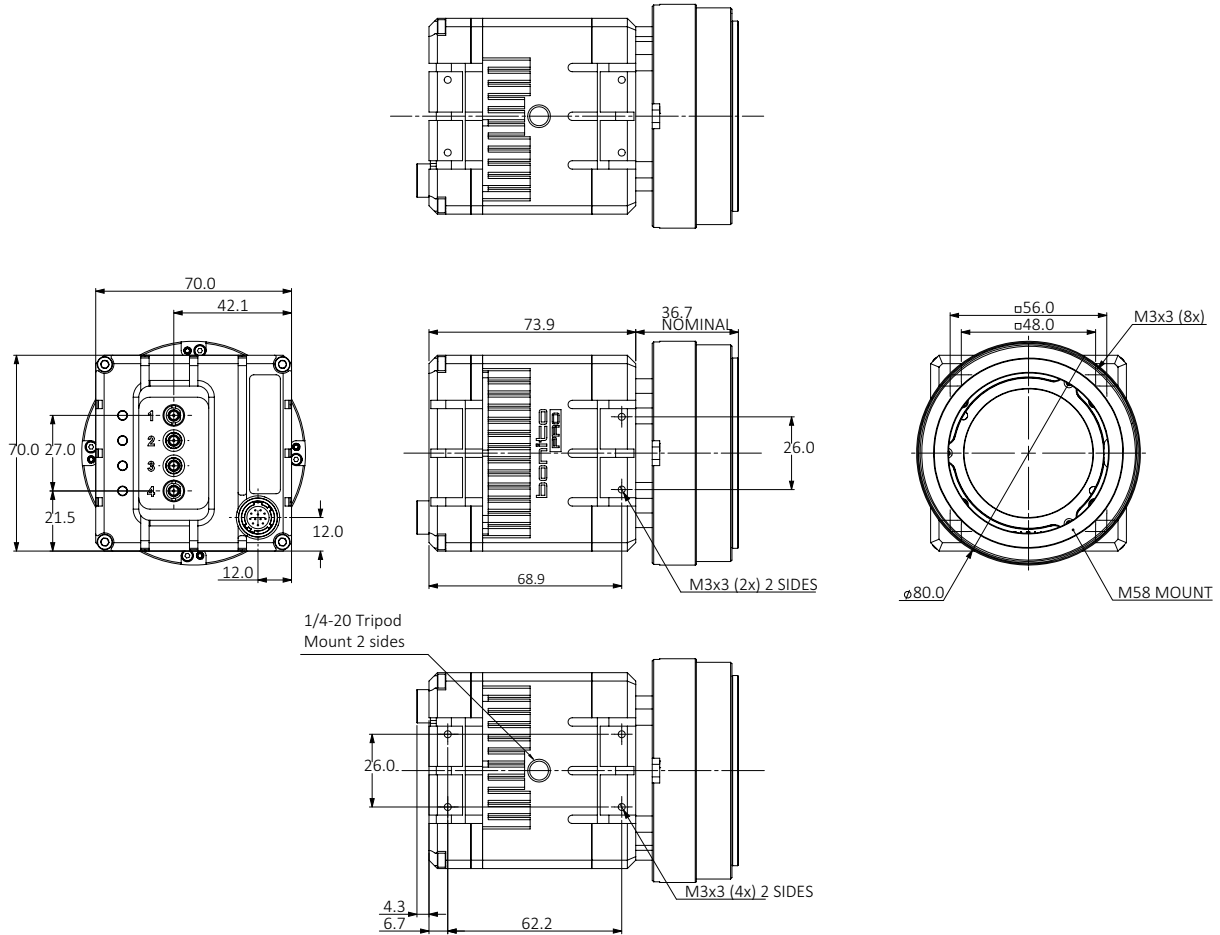

Figure 17: Bonito PRO camera with M58-Mount PA, mechanical dimensions



### M58-Mount PA order code

Contact the Allied Vision Sales team to purchase the Bonito PRO series camera with M58-Mount PA option (order code Bonito PRO...-13).

# Flange focal distance

## F-Mount

Flange focal distance is the optical distance from the mounting flange to image sensor die. Bonito PRO F-Mount cameras are calibrated to a standard 46.50 mm flange focal distance.

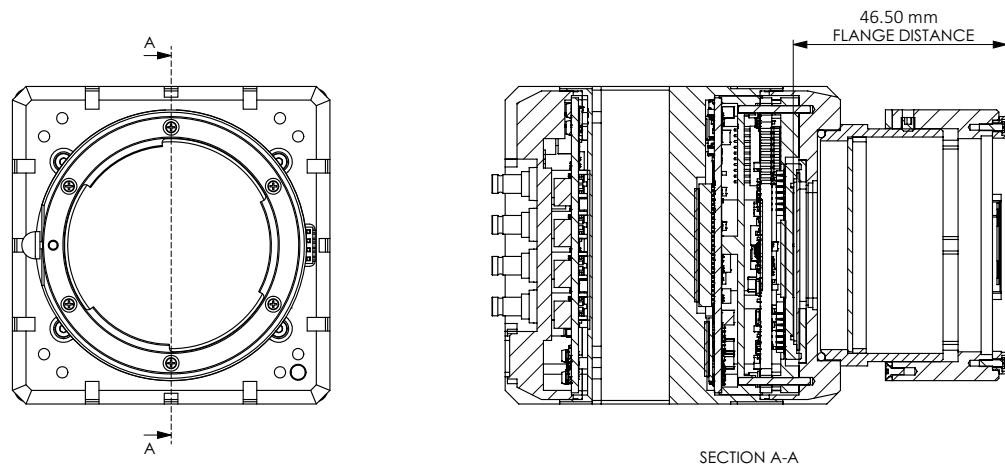

Figure 18: F-Mount flange distance cross section

## F-Mount PA

Bonito PRO F-Mount PA cameras are calibrated to a standard 46.50 mm flange focal distance.

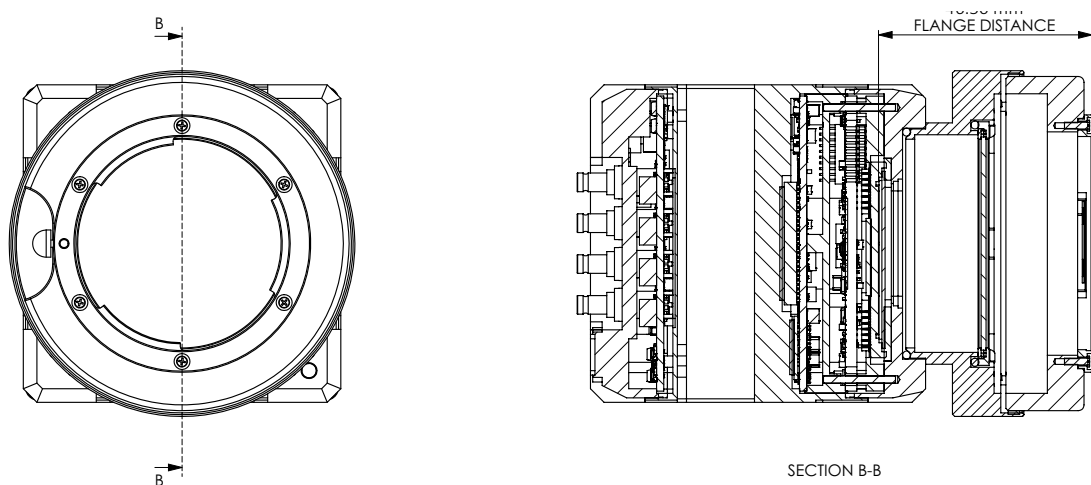

Figure 19: F-Mount PA flange distance cross section

## EF-Mount PA

Bonito PRO M58-Mount cameras are calibrated to a standard 44.00 mm flange focal distance.

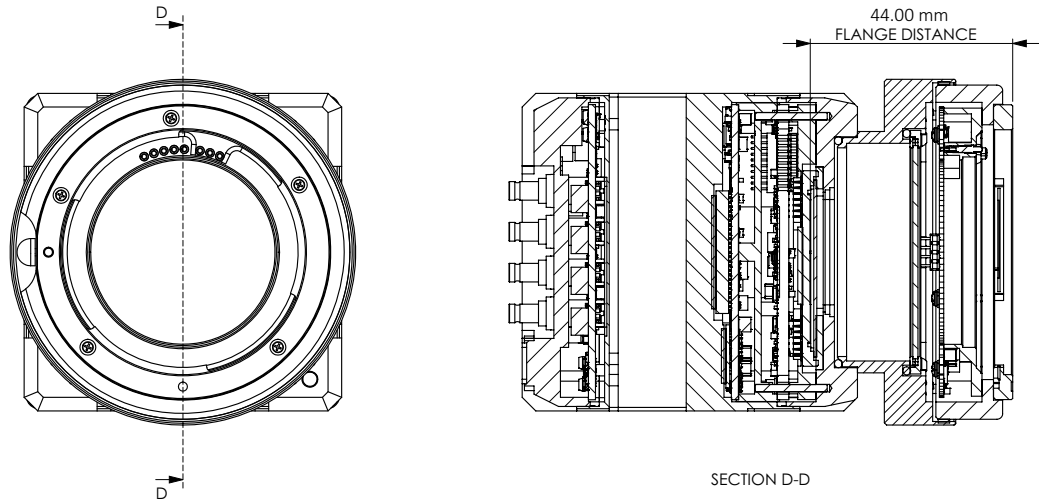

Figure 20: EF-Mount PA flange distance cross section

## M42-Mount

Bonito PRO M42-Mount cameras are calibrated to a standard 45.46 mm flange focal distance.

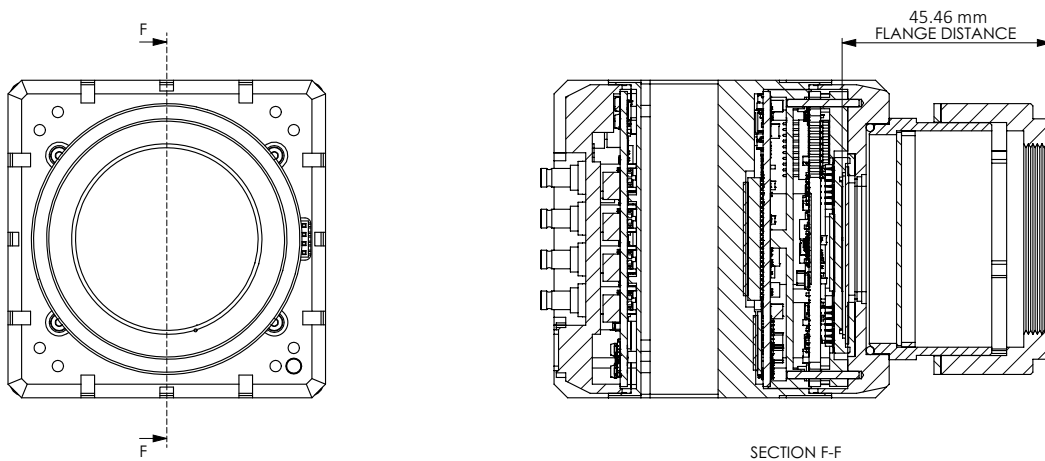

Figure 21: M42-Mount flange distance cross section

## M42-Mount PA

Bonito PRO M42-Mount PA cameras are calibrated to a standard 45.46 mm flange focal distance.

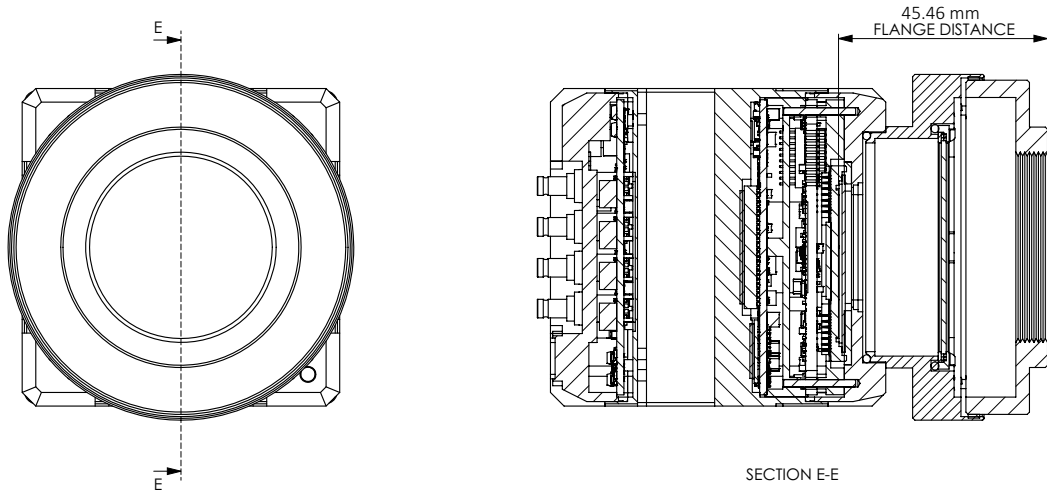

Figure 22: M42-Mount PA flange distance cross section

## M58-Mount

Bonito PRO M58-Mount cameras are calibrated to a standard 12.71 mm flange focal distance.

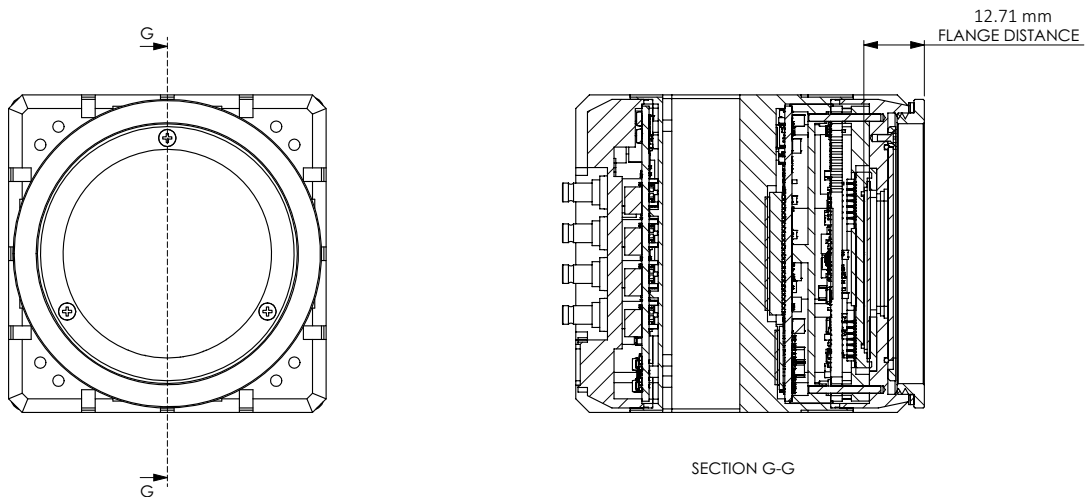

Figure 23: M58-Mount flange distance cross section

## M58-Mount PA

Bonito PRO M58-Mount cameras are calibrated to a standard 46.50 mm flange focal distance.

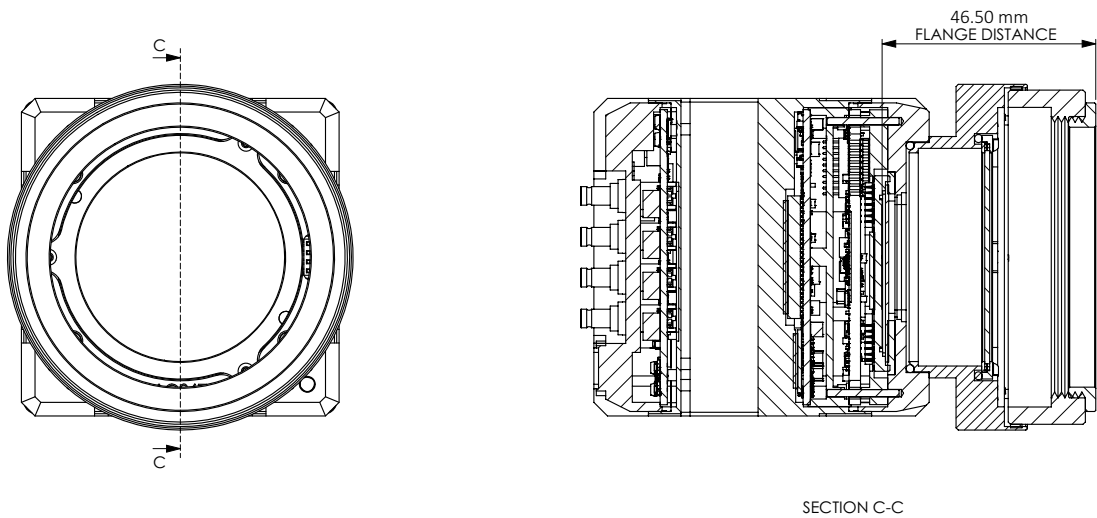

Figure 24: M58-Mount PA flange distance cross section

## Adjustment of F-Mount

The F-Mount is adjusted at the factory and should not require adjusting. If for some reason the lens mount requires adjustment, use the following method.

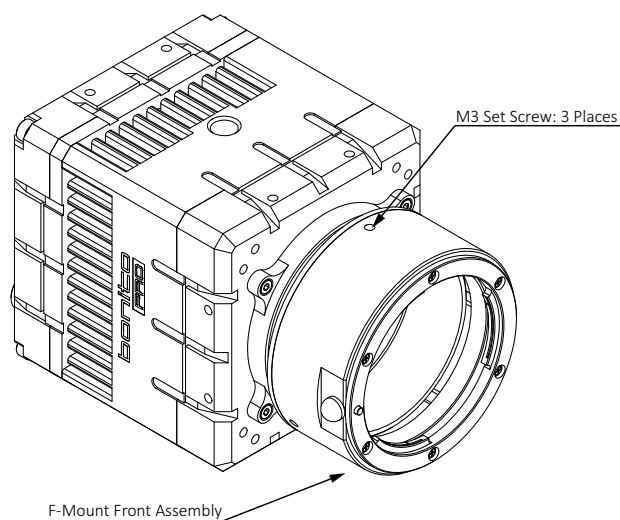

Figure 25: Bonito PRO camera with F-Mount isometric view

## Adjusting the F-Mount

Prerequisite: Use an F-Mount compatible lens that allows an infinity focus.

1. Attaching F-Mount compatible lens  
Attach the lens to the camera using a counter-clockwise rotation of about a quarter turn. The lens snaps into place and the lens flange and camera flange mates over the full circumference.
2. Loosening F-Mount front assembly  
Pressing the F-Mount assembly against the camera body, loosen the three set screws with a 1.5 mm hex ball driver.
3. Imaging to infinity  
Set the lens to infinity and image a distant object (10 to 15 meters).
4. Gently move the F-Mount front assembly until focused and lock it in place.

## Planarity adjustable mounts

Bonito PRO cameras allow planarity adjustment of the mount relative to the camera sensor. Adjustment can be made for overall flange focal distance (Z distance), and planarity (Z-tilt). The following steps describe Z adjustment using a standard lens and a target. However, measurement tools such as an optical depth micrometer could also be used.



### NOTICE

Modifying the factory default adjustment is under the responsibility of the user. Exercise caution when modifying the planarity adjustment. Use a 1.5 mm hex ball driver to loosen the three spring loaded screws, adjust the tilt adjustment screws as required, then secure the screws.

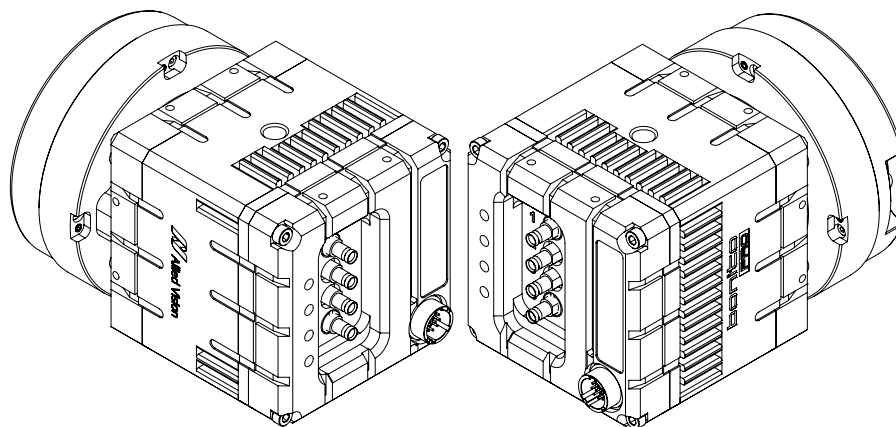

Figure 26: Location of tilt adjustment screws

1. Using a compatible lens, set the lens to infinity and image on a target (10 to 15 meters). Target should highlight focus levels at center image and at the corners of the image. A lens with a long focal length, or adjustable zoom lens, allows more precision for this operation and reduce the overall size of your target.
2. Use a 1.5 mm hex ball head driver to loosen the screws. Adjust the three tilt adjustment screws, until all targets are in focus.
3. Tighten the three screws and recheck the focus.

## Sensor position accuracy

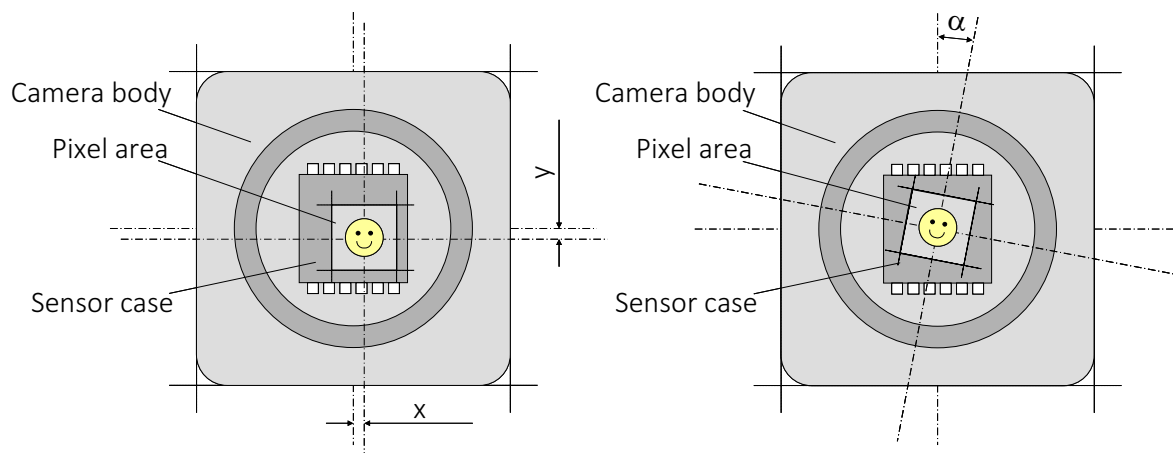

Figure 27: Sensor position accuracy

The following table defines the manufacturing accuracy of fitting sensors into Bonito PRO cameras.

Criteria	Subject	Properties
Reference Point	Sensor	Center of pixel area (photo sensitive cells)
	Camera	Center of camera front flange (outer case edges)
Accuracy	x-axis y-axis	$\pm 250 \mu\text{m}$ (sensor shift)
	z-axis	$\pm 10 \mu\text{m}$ (optical back focal length)
	$\alpha$	$< 1^\circ$ (sensor rotation)
Alignment method		Optical alignment of photo sensitive sensor area into camera front module (lens mount front flange).

Table 17: Sensor position accuracy criteria

# Optical filters

All Bonito PRO color models are equipped with an infrared block filter (IR cut filter). This filter prevents infrared light from passing to the sensor. In the absence of an IR cut filter, images are dominated by red and are incapable of being properly color balanced. Monochrome and NIR models do not use an IR cut filter.

The following figure shows the filter transmission response for the type IRC30 IR cut filter, and the optional type Schneider 486 IR cut filter and B270 ASG protection glass.

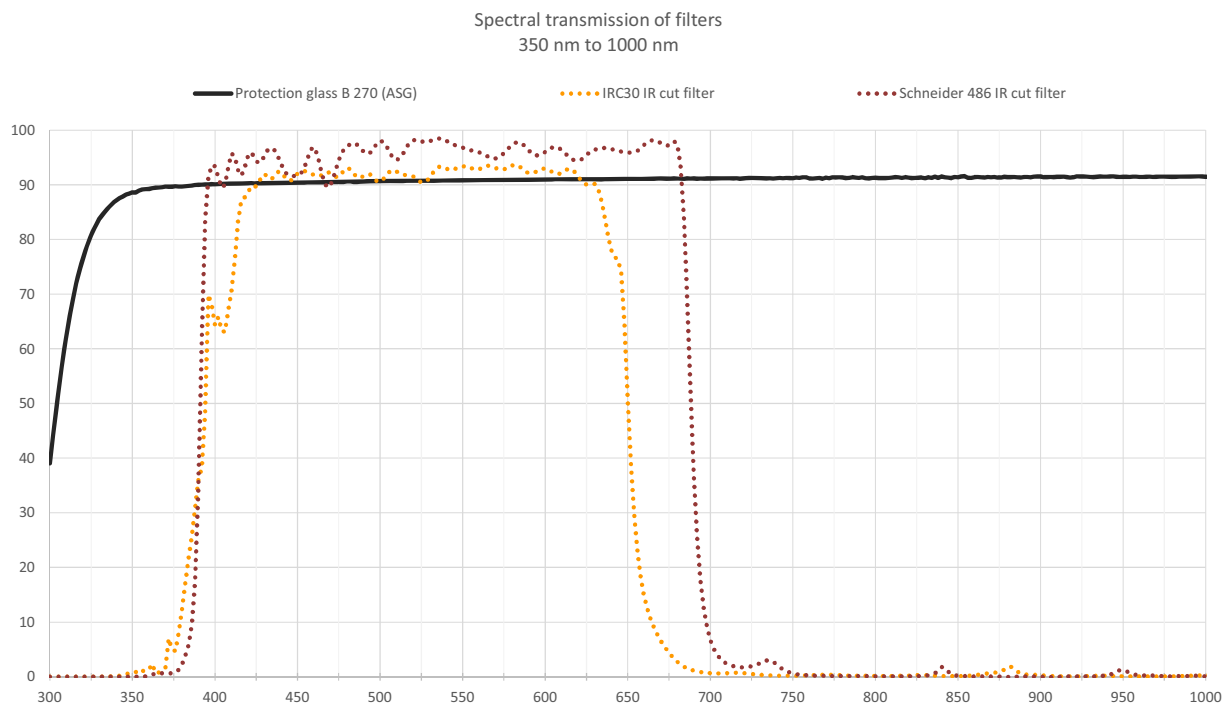
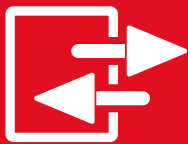

Figure 28: Optical filter transmission response



# Camera interfaces



This chapter includes:

- A general description of the inputs and outputs (including trigger features)
- I/O connector pin assignments
- I/O block diagrams
- A general description of trigger rules such as timing diagram and definitions

## Back panel

This section provides information on CoaXPress connectors, Hirose IO port, status LEDs, and trigger features.

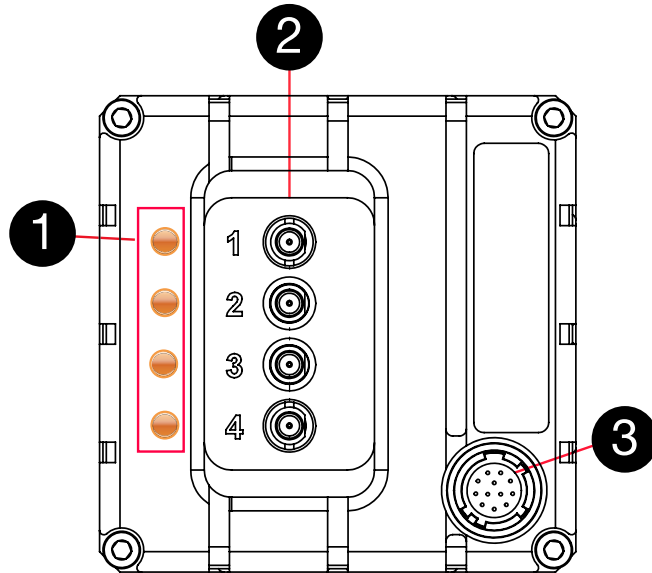

Figure 29: Bonito PRO ports and LEDs

<b>1</b>	Status LEDs
<b>2</b>	4 × 1.0, 2.3 DIN type connectors
<b>3</b>	Hirose I/O port, HR10A-10R-12PB connector

## Status LEDs

The color and state of the LEDs has the following meaning.

State	Indication
No power	Off
System booting	Solid orange
Powered, but not connected (not applicable to a device reliant on PoCXP power)	Slow pulse (1 hertz) red
Connection detection in progress, PoCXP active	Fast flash (12.5 hertz) alternate green and orange Shown for a minimum of one second even if the connection detection is faster.
Connection detection in progress, PoCXP not in use	Fast flash (12.5 hertz) orange Shown for a minimum of one second even if the connection detection is faster.
Device or host incompatible, PoCXP active	Slow flash (0.5 hertz) alternate red and green
Device or host incompatible, PoCXP not in use	Slow flash (0.5 hertz) alternate red and orange
Device or host connected, but no data being transferred	Solid green
Device or host connected, waiting for event (for example trigger, exposure pulse)	Slow pulse (1 hertz) orange
Device or host connected, data being transferred	Fast flash (12.5 hertz) green
Error during data transfer (for example CRC error, single bit error detected)	Slow pulse (0.5 hertz), red In case of multiple errors, there shall be at least two green fast flash pulses before the next error is indicated
Connection test packets being sent	Slow flash (0.5 hertz) alternate green and orange
Compliance test mode enabled	Slow flash (0.5 hertz) alternate red then green then orange
System error (for example internal error)	Fast flash (12.5 hertz) red

*Table 18: Status of LEDs*

## CoaXPress interface

The Bonito PRO is powered through the 12-pin Hirose I/O port, or the CXP-6 four DIN 1.0, 2.3 connections by using any standard PoCXP supported frame grabber. The PoCXP interface supports power up to 13 watts per cable.

See the Hardware Selection for Allied Vision Bonito PRO Cameras application note for a list of supported CoaXPress (CXP-6) frame grabbers and cables

### Maximum cable length

The maximum cable length between the Bonito PRO camera and the host computer is dependent on the bit rate and the type of coax cable used. For more information refer to the J1A CoaXPress Standard Version 1.1.1.

### CoaXPress physical topology

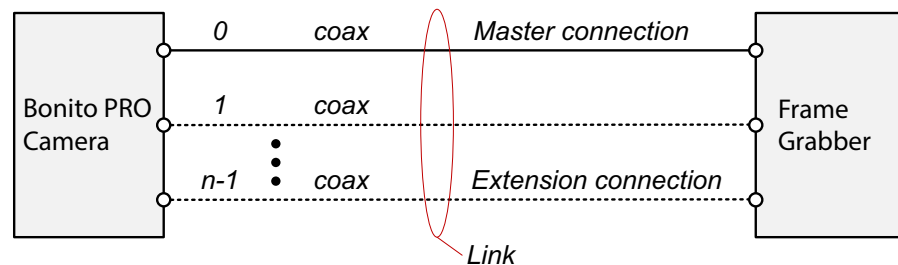

Figure 30: CoaXPress physical topology

Each connection provides the following signaling functions:

- High-speed serial (camera to frame grabber down connection), at up to 6.25 Gbps per line
- Low speed serial (frame grabber to camera up connection), at 20.83 Mbps
- Power (host to device), up to 13 watts.

A dedicated high-speed connection from host to device is allowed for high-speed triggers and camera control. This connection does not support power.

The link protocol defines the transfer of triggers, general purpose I/O, control data and high-speed streaming data over a link.

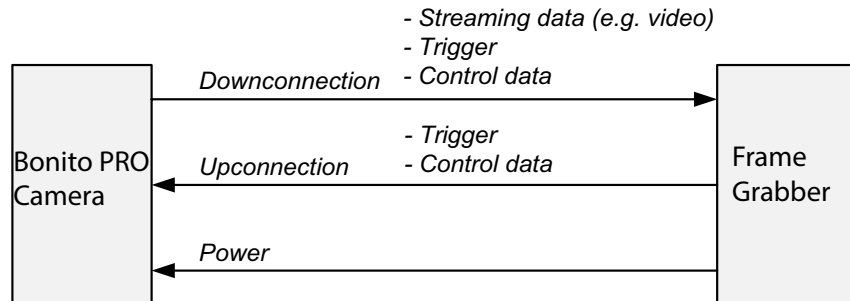

Figure 31: Signaling connections and data flow

Both the up connection and down connection use 8B/10B code. 8B/10B is an industry-standard code that maps 8-bit data to 10-bit data to achieve DC balance on the connection, while also allowing clock recovery by ensuring regular transitions.



**Discovery bit rate**

The discovery bit rate is CXP-1.

## Camera I/O connector pin assignment

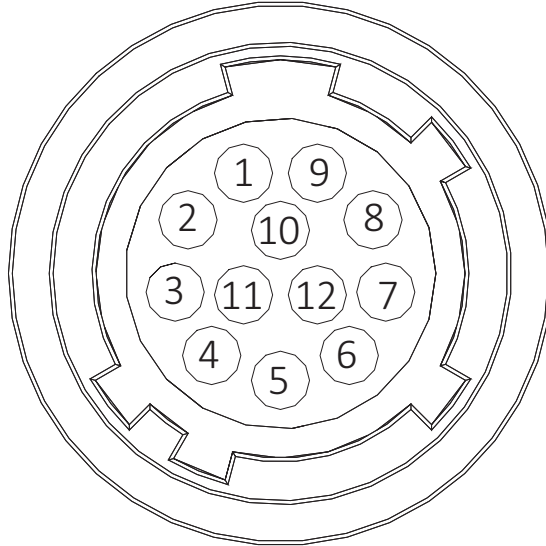

Camera side Hirose HR10A-10R-12PB connector					
Pin	Signal	Direction	Level	Description	I/O cable color code
1	Camera GND	In	0 VDC	Ground for camera power supply	Blue
2	Camera Power	In	24 VDC $\pm$ 2.4 VDC	Camera power supply	Red
3	Out 4	Out	Open emitter maximum 5 mA	Opto-isolated Output 4 (SyncOut4)	Pink
4	In 1	In	LVTTL maximum 3.3 VDC	Non-isolated Input 1 (SyncIn1)	Gray
5	Out 3	Out	Open emitter maximum 5 mA	Opto-isolated Output 3 (SyncOut3)	Yellow
6	Out 1	Out	3.3 VDC LVTTL maximum 50 $\mu$ A	Non-isolated Output 1 (SyncOut1)	Green
7	Isolated IO GND	In	0 VDC	Isolated input signal ground	Brown
8	RxD RS232	In		Reserved for future use	White
9	TxD RS232	Out		Reserved for future use	Black
10	Isolated Out Power	In	Common VCC for outputs 5 to 24 VDC	Power input for opto-isolated outputs	Orange

Table 19: Camera I/O connector pin assignment and cable color coding (sheet 1 of 2)

Camera side Hirose HR10A-10R-12PB connector					I/O cable color code
Pin	Signal	Direction	Level	Description	
11	In 2	In	$U_{in}(\text{high}) = 5 \text{ to } 24 \text{ VDC}$ $U_{in}(\text{low}) = 0 \text{ to } 0.8 \text{ VDC}$	Input 2 opto-isolated (SyncIn2)	White and Black
12	Out 2	Out	3.3 VDC LVTTTL maximum 50 $\mu\text{A}$	Non-isolated Output 2 (SyncOut2)	White and Brown

Table 19: Camera I/O connector pin assignment and cable color coding (sheet 2 of 2)

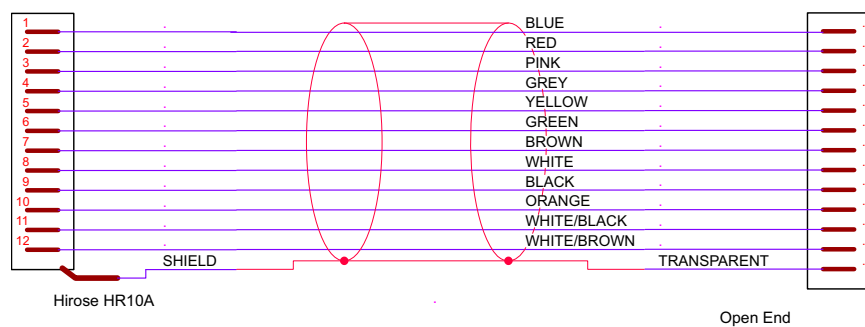

Figure 32: Bonito PRO cable color coding

The General Purpose I/O port uses a Hirose HR10A-10R-12PB connector on the camera side. The mating cable connector is Hirose HR10A-10P-12S.



#### Hirose connector

The cable side Hirose 12-pin female connector is available for purchase from Allied Vision. Order code: K7600040.

# I/O definition

## Camera Power

The Bonito PRO camera can be powered through the Hirose I/O port, via **Pin 1** Camera GND and **Pin 2** Camera Power, or through the CoaXPress interface if using a Power over CoaXPress (PoCXP) supported frame grabber.

Cameras powered by both the Hirose I/O port and the CoaXPress interface uses the power provided by Hirose I/O port only.

**Pin 2**, Camera Power, supports an input voltage of 24 VDC  $\pm$  2.4 VDC. The camera does not power in reverse polarity. Exceeding the 24 VDC  $\pm$  2.4 VDC could damage the camera.

## Input triggers

Input triggers allow the camera to be synchronized to an external event. The camera can be programmed to trigger on the rising edge, falling edge, both edges, or level of the signal. The camera can also be programmed to capture an image at some programmable delay time after the trigger event.

### In 1 (Non-isolated)

**In 1** is not electrically isolated and can be used when environmental noise is insignificant and faster trigger response is required. The required trigger signal is low voltage TTL 3.3 VDC. Tie trigger ground to Camera GND to complete the trigger circuit.



#### NOTICE

Exceeding 5.1 VDC on **In 1** can permanently damage the camera.



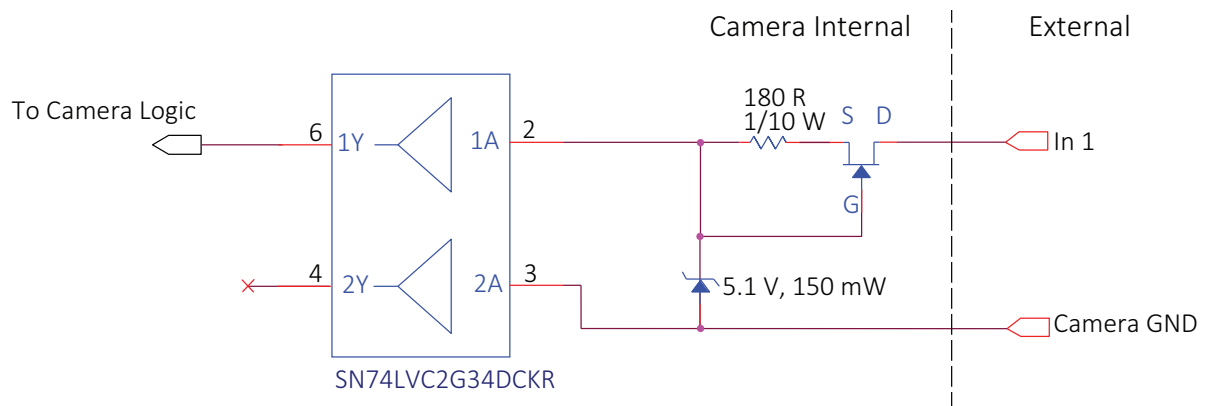

Figure 33: Bonito PRO internal circuit diagram for non-isolated input trigger

## In 2 (Opto-isolated)

**In 2** is optically isolated and can be used in electrically noisy environments to prevent false trigger events. Tie trigger ground to Isolated IO GND to complete the trigger circuit. Compared to the non-isolated trigger, **In 2** has a longer propagation time. It can be driven from 5 to 24 VDC with a minimum current source of 5 mA.

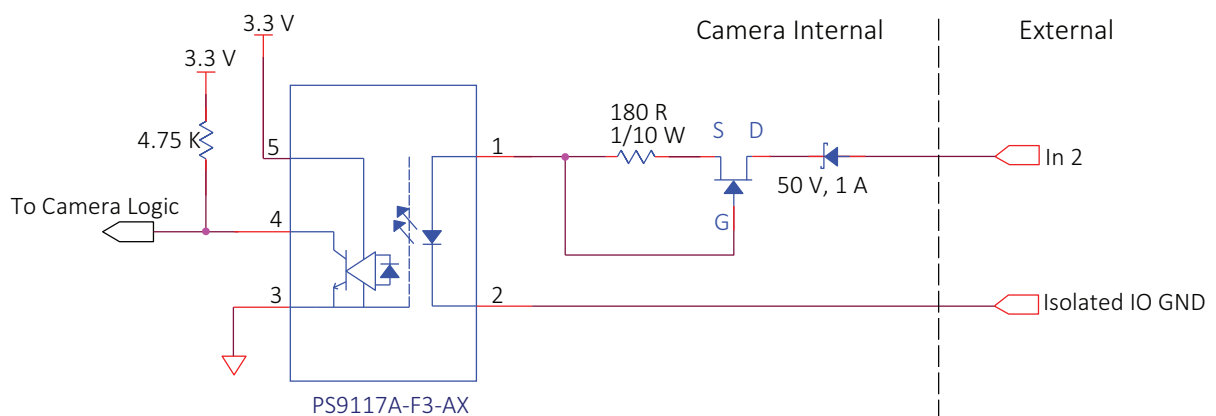

Figure 34: Bonito PRO internal circuit diagram for opto-isolated input trigger

## Isolated IO GND

The Isolated IO GND connection provides the user ground reference and return path for **In 2**. It is recommended that the ground wiring be physically close to the **In 2** wiring to prevent parasitic coupling. For example, a good cable design connects **In 2** to one conductor of a twisted pair, Isolated IO GND to the second conductor of the same twisted pair.

## Output signals

Output signals can be assigned to a variety of internal camera signals via software. They can be configured to active high or active low. The internal camera signals are listed as follows:

<b>Exposing</b>	Corresponds to when camera is integrating light.
<b>Trigger Ready</b>	Indicates when the camera is ready to accept a trigger signal.
<b>Trigger Input</b>	A relay of the trigger input signal used to “daisy chain” the trigger signal for multiple cameras.
<b>Readout</b>	Valid when camera is reading out data.
<b>Imaging</b>	Valid when camera is exposing or reading out.
<b>Strobe</b>	Programmable pulse based on one of the previously defined events.
<b>GPO</b>	User programmable binary output.

## Isolated Out Power

The Isolated Out Power connection provides power for isolated signals **Out 3** and **Out 4**. The voltage requirement is 5 to 24 VDC. The current requirement for this supply is a function of the optical isolator collector current and the number of outputs used in the system. Isolated Out Power wiring should be physically close to **Out 3** or **Out 4** wiring to prevent parasitic coupling.

## Out 1 and 2 (Non-isolated)

**Out 1** and **Out 2** signals are not electrically isolated and can be used when environmental electrical noise is insignificant and faster trigger response is required. Tie signal ground to Camera GND to complete the external circuit. The output signal is a low voltage TTL, maximum 3.3 VDC. It is not suitable for driving loads in excess of 50  $\mu$ A.

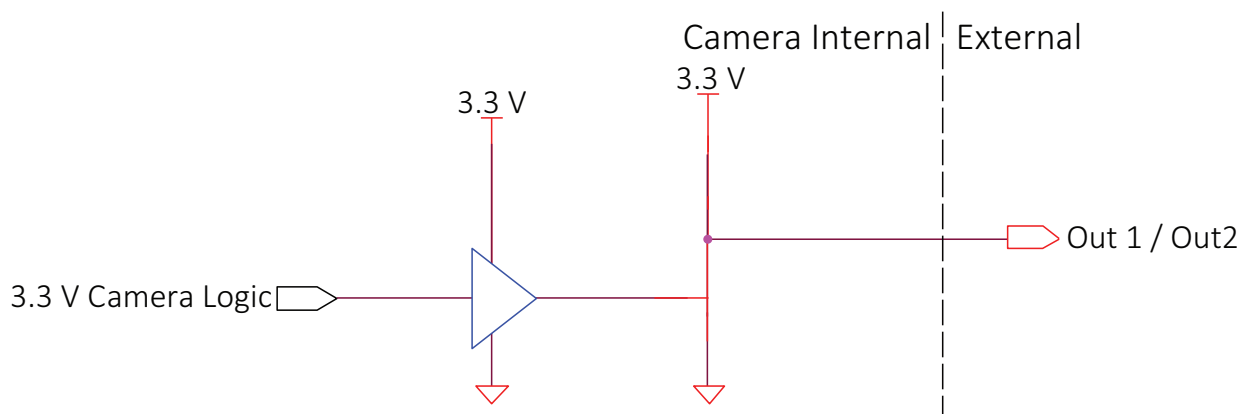

Figure 35: Bonito PRO Out 1 or Out 2 trigger circuit

## Out3 and Out4 (Opto-isolated)

**Out3** and **Out4** signals are optically isolated and require the user to provide a voltage level, Isolated Out Power. The **Out3, Out4** signal should be grounded by adding an external load resistor as shown in the following figure and table. Isolated Out Power can be configured between 5 to 24 VDC.

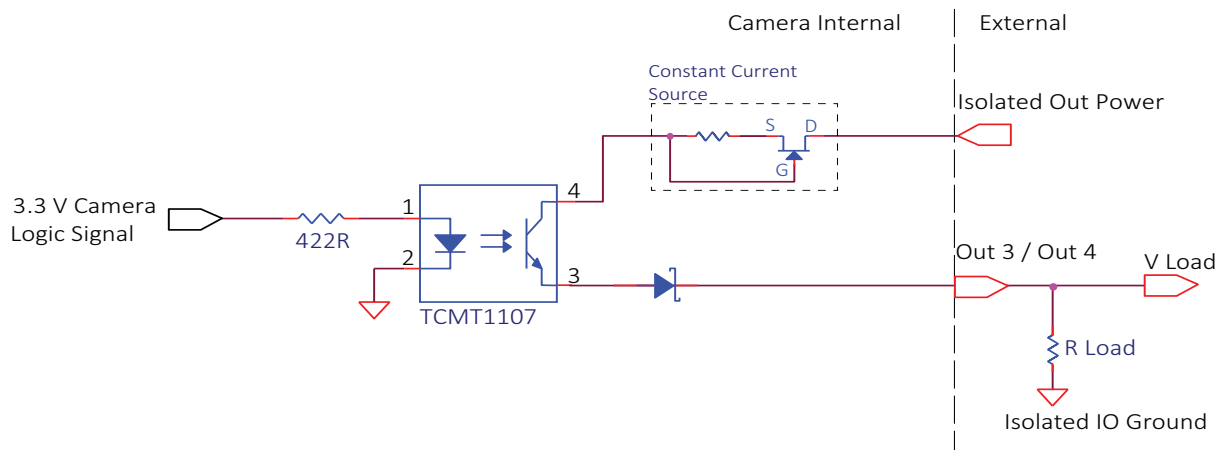

Figure 36: Bonito PRO Out 3 and Out 4 trigger circuit

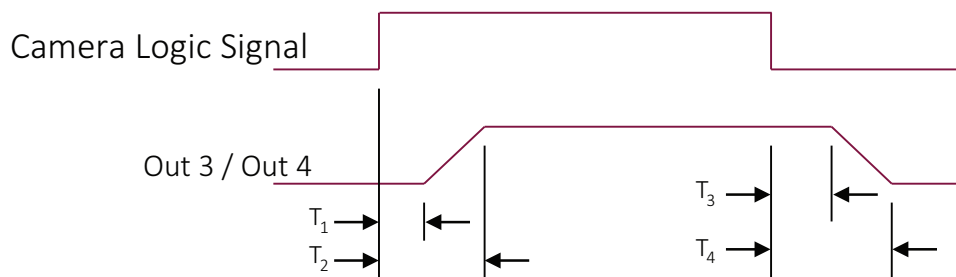

Figure 37: Bonito PRO Out 3 and Out 4 timing diagram

The influence of various Isolated Out Power values and load values on the timing response of the trigger is indicated in the following table. Trigger current, Out ICC, is a function of Isolated Out Power voltage and Load resistor R.

Isolated Out Power	OUT ICC	R Load	V Load	R Power Dissipation	T <sub>1</sub>	T <sub>2</sub>	T <sub>3</sub>	T <sub>4</sub>
5 VDC	8 mA	500 Ω	4.2 VDC	35 mW	1.2 μs	5.4 μs	5.6 μs	64 μs
5 VDC	5 mA	2.4 KΩ	4.0 VDC	6.7 mW	1.2 μs	5.4 μs	4.4 μs	34 μs

Table 20: Bonito PRO trigger circuit values (sheet 1 of 2)

Isolated Out Power	OUT ICC	R Load	V Load	R Power Dissipation	T <sub>1</sub>	T <sub>2</sub>	T <sub>3</sub>	T <sub>4</sub>
12 VDC	2.1 mA	5 KΩ	10.4 VDC	21.6 mW	1.2 μs	10 μs	4.0 μs	47 μs
24 VDC	1.8 mA	10 KΩ	18.4 VDC	33.9 mW	1.2 μs	15 μs	3.4 μs	70 μs

Table 20: Bonito PRO trigger circuit values (sheet 2 of 2)

## EF lens control

EF lens control is available for Bonito PRO cameras. EF lens control allows focus and aperture control via host software.

See the Modular Concept for information on lens mount options available with Bonito PRO camera.



### NOTICE

#### Maximum power via PoCXP

The maximum power supplied via PoCXP is 13 watts per cable at a nominal 24 VDC. EF lens power requirements varies from lens to lens; however, typical ratings are in the 3 to 4 watt range.

### Operation

1. Connect an EF lens to the camera before powering up the camera.
2. Power up the camera, and open the camera control software.
3. Use `EFLensInitialize` command to initialize the EF lens. This command is automatically executed on power up and when lens is attached to camera.
4. Adjust the focus and aperture using `EFLensFocus` and `EFLensFStop` controls, respectively.
5. If the lens does not operate as expected, see `EFLensState` and `EFLensLastError`. EF lens controls are described further in the `EFLensControl` section of the Bonito PRO Features Reference.

# Camera trigger

## Trigger timing diagram

The following diagram explains the general trigger concept.

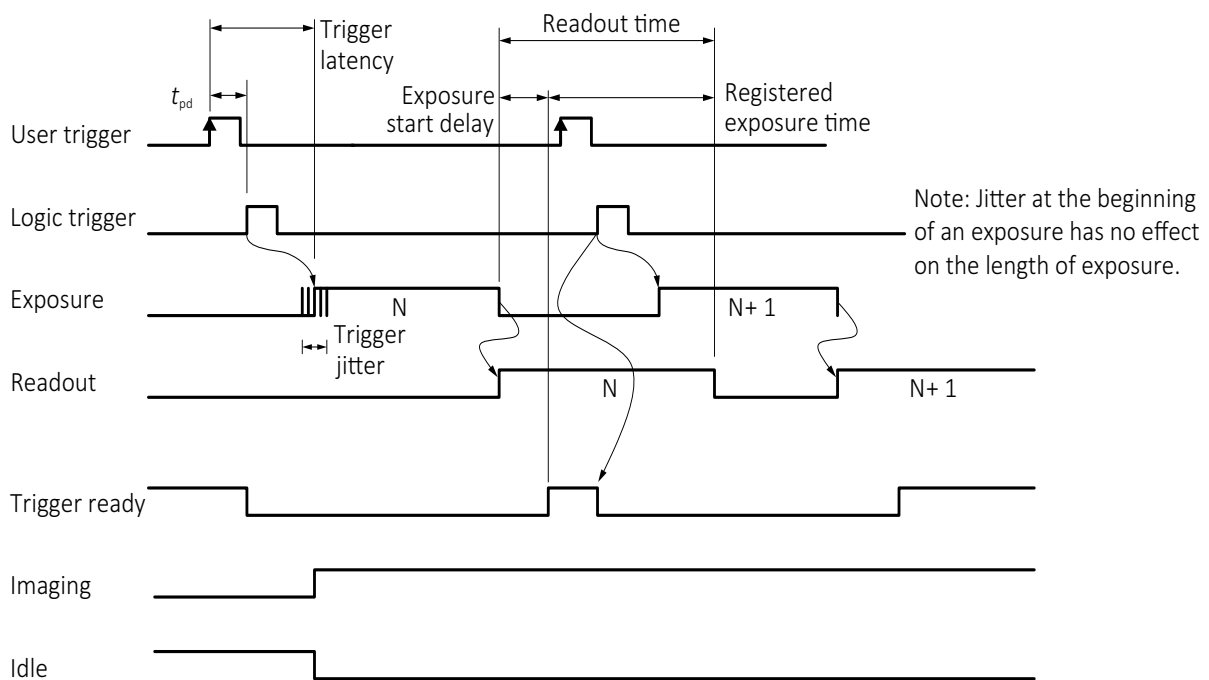

Figure 38: Bonito PRO internal signal timing waveforms

## Trigger definitions

Term	Definition
User trigger	Trigger signal applied by the user (hardware trigger, software trigger).
Logic trigger	Trigger signal seen by the camera internal logic (not visible to the user).
$t_{pd}$	Propagation delay ( $t_{pd}$ ) between the user trigger and the logic trigger.
Exposure	High when the camera image sensor is integrating light.
Readout	High when the camera image sensor is reading out data.
Trigger latency	Time delay between the user trigger and the start of exposure.
Trigger jitter	Deviation from the trigger latency time.

Table 21: Explanation of signals in timing diagram (sheet 1 of 2)

Term	Definition
Trigger ready	Indicates to the user that the camera accepts the next trigger.
Registered exposure time	Exposure time value currently stored in the camera memory.
Exposure start delay	Registered exposure time subtracted from the readout time and indicates when the next exposure cycle can begin such that the exposure ends after the current readout.
Interline time	Time between sensor row readout cycles.
Imaging	High when the camera image sensor is either exposing and/or reading out data.
Idle	High if the camera image sensor is not exposing and/or reading out data.

Table 21: Explanation of signals in timing diagram (sheet 2 of 2)

## Trigger rules

- The end of exposure always triggers the next Readout.
- The end of exposure must always end after the current Readout.
- The start of exposure must always correspond with the Interline Time if Readout is true.
- Exposure start delay equals the readout time minus the registered Exposure Time.
- The user trigger pulse width should be at least three times the width of the trigger latency as indicated in the Specifications chapter.

## Triggering during the idle state

For applications requiring the shortest possible trigger latency and the smallest possible trigger jitter, the user trigger signal should be applied when Imaging is false and Idle is true. In this case, trigger latency and trigger jitter are as indicated in the Specifications chapter.

## Triggering during the readout state

For applications requiring the fastest triggering cycle time whereby the camera image sensor is exposing and reading out simultaneously, apply the user trigger signal as soon as a valid trigger ready is detected. In this case, trigger latency and trigger jitter can be up to one row time since Exposure must always begin on an Interline boundary.



For a more detailed description of the trigger concept for advanced users and special scenarios, see the Triggering Concept application note:

[www.alliedvision.com/en/support/technical-papers-knowledge-base.html](http://www.alliedvision.com/en/support/technical-papers-knowledge-base.html)

# Image data flow

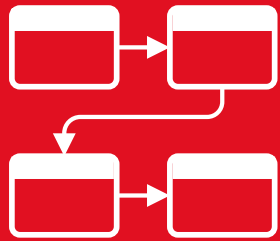

This chapter presents diagrams that illustrate data flow and bit resolution of the image data.

For a complete description of individual features, see the Bonito PRO Features Reference.

## Bonito PRO image data flow

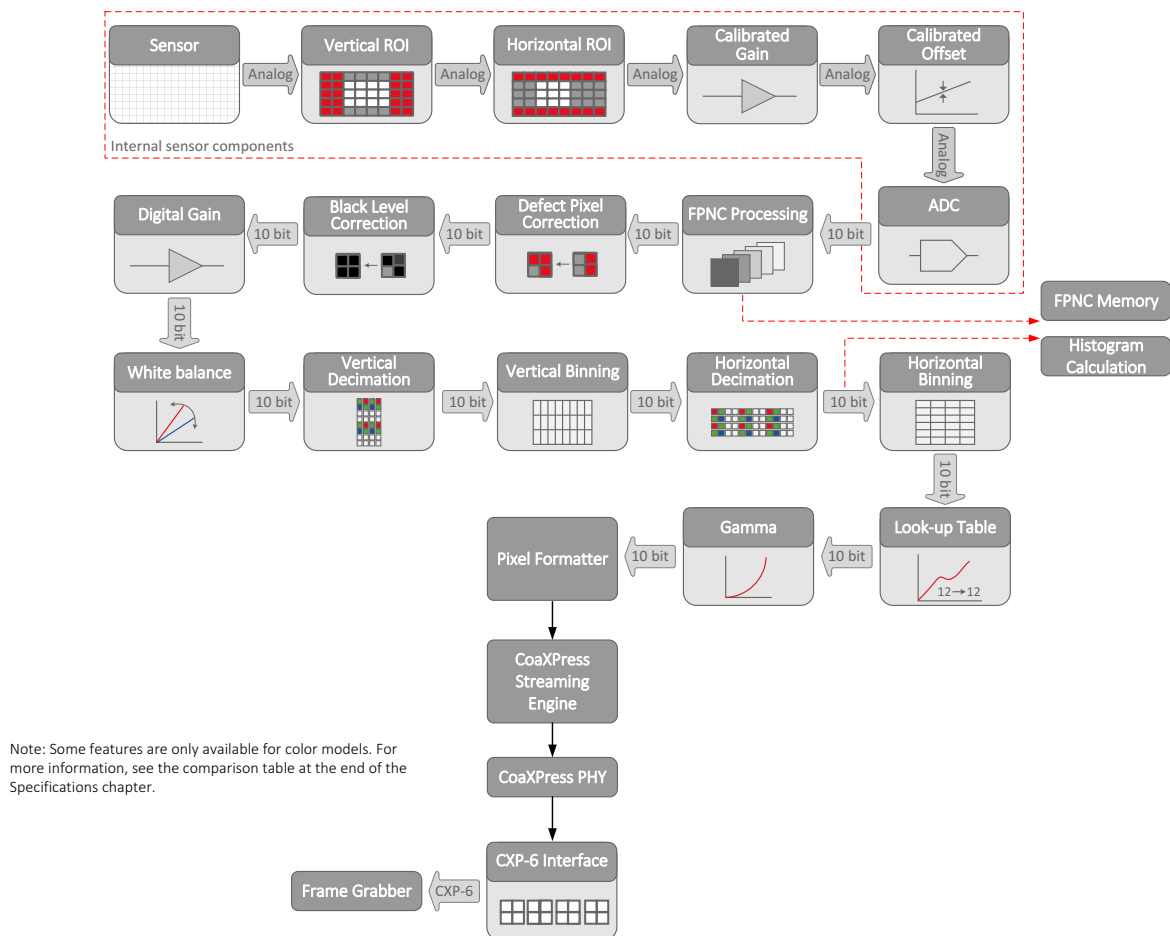

Figure 39: Bonito PRO image data flow



# Cleaning optical components



This chapter describes safety instructions and cautions for cleaning lenses, optical filters, or sensors.



Read these instructions before you contact Allied Vision or your Allied Vision distribution partner for assistance.

Contact Allied Vision or your Allied Vision distribution partner if you are not familiar with the procedures described in this chapter.

## Keep optical components clean

The best way to ensure the camera remains clean is to avoid penetration of foreign substances into the camera.

When screwing or unscrewing the camera lens or dust cap, hold the camera with the mount opening towards the floor. This minimizes the possibility of any contaminants falling on the glass surface. Always store cameras and lenses with dust-caps on.

## Identifying impurities

If you observe any image artifacts in your video preview of your Bonito PRO camera you may have impurities either on the lens, optical filter, or on the sensor protection glass. Every Bonito PRO camera is cleaned prior to sealing and shipment; however, impurities may develop due to handling or unclean environments.

As shown in the following figure, impurities (dust, particles, or fluids) on the sensor or optical components appear as a dark area, patch or spot on the image and remain fixed in the preview window while you rotate the camera over the target.

Do not confuse this with a pixel defect which appears as a distinct point. Particles can either rest loosely or can be more or less stuck to the optical surface.

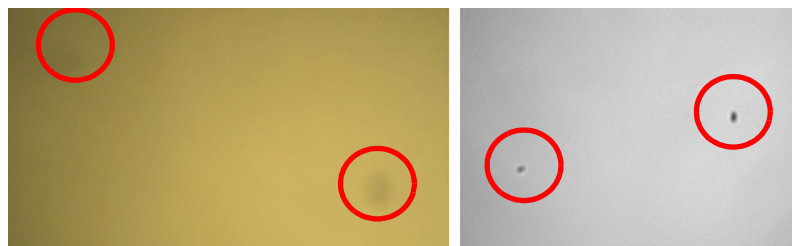

Figure 40: Image with tiny dust on the filter (left) and dust on the sensor (right)

## Locating impurities

Before you dismount the lens, you should find out if the impurity is on the filter, lens, or sensor.

1. Start acquiring a uniform image (for example, a white sheet of paper) with the camera.
2. To identify the affected surface, move the suspected optical component and see if the contamination follows this movement.
  - a. If you move only the lens (not the camera) and the impurity moves as well, the impurity is on the lens.
  - b. If you move the IR cut filter or protection glass window and the impurity moves as well, the impurity is on the filter or protection glass. Carefully remove the filter or protection glass and clean it on both sides using the techniques explained in the next section. If the impurity is neither on the lens nor the IR cut filter or protection glass, it is probably on the sensor.



### NOTICE

#### Removing the optical filter

Do not attempt to remove the camera optical filter for Bonito PRO cameras. Contact [support@alliedvision.com](mailto:support@alliedvision.com) for assistance.

## Materials for cleaning optical components

Cleaning materials for optical components:

- Optic approved lens cotton, cloth, or tissue that is chemically pure and free from silicones and other additives.
- Optic approved low residue cleaning liquid.



#### Optical cleaning liquid material safety data sheets

Read the material safety data sheet (MSDS) for the optical cleaning liquid before cleaning your camera and optics. The MSDS provides important information including hazard identification, first aid measures, handling and storage, and PPE.



### NOTICE

- Dry swabs or tissue may cause scratches.
- Metal tools may cause scratches.
- Disposable cotton cosmetic swabs may contain contaminants harmful to optical glass.
- Cosmetic cotton may cause scratches or get caught in small gaps.
- Consumer eyeglass cleaning cloths may be pretreated with silicone harmful to optical glass.
- Aggressive cleaners like benzene, acetone, or spirits may damage the surface.

# Cleaning instructions

## Workplace pre-conditions

- Perform all cleaning operations (lenses, optical filter, and sensor) in a dust-free clean-room.
- Avoid touching the optical components with your fingers or any hard material.
- Nitrile cleanroom gloves or powder free latex gloves are recommended to maintain low particulate levels.
- Use an ESD mat to prevent damage from an electrostatic discharge.

## Cleaning instructions

1. Unplug the camera from any power supply before cleaning.
2. Apply a small amount of cleaning liquid to a new lens cleaning cotton, cloth, or tissue. The cotton, cloth, or lens tissue should be moist, but not dripping.



3. Hold the camera sensor diagonally upwards. Ensure that the camera is away from your body to prevent particles like skin flakes from falling on the sensor.
4. Wipe the glass surface with a spiral motion from the center to the rim. Normally, several spiral wipes are recommended. Wipe only on glass avoiding contact to metal surfaces, because microscopic dirt could be released and could cause scratches on the glass.
5. When you have finished cleaning, examine the surface in a strong light. Take an out-of-focus picture of a flat, illuminated surface to see if any dirt or dust remains.
6. If dust spots remain, repeat this procedure using new clean lens tissue.

## Cleaning issues

If you notice that the camera lens or sensor is not clean after attempting to clean twice, or if you have any questions regarding cleaning your camera, contact your Allied Vision distribution partner.

## Cleaning with compressed air

Allied Vision does not recommend cleaning Bonito PRO cameras with compressed air.



### NOTICE

- Compressed air at high pressure and/or shorter operating distances may push dust into the camera or lens and physically damage the camera, sensor, or optical components.
- Propellant from non-optic approved compressed air products may leave a residue on the camera or lens and may physically damage the camera, sensor, or optical components.
- Compressed air may contain oil or moisture that could contaminate or damage the optical components.
- Use an air blower or compressed air only if you are familiar with cleaning a camera using this method.

If you want to clean your camera with compressed air despite of all the warnings:

- Use an optic approved compressed air product or compressor.
- Use an anti-static ionizer attachment to reduce the risk of static-caused damage.
- Use a filter to remove moisture and oil from the air.
- Use short directed bursts of air to remove impurities.



Compressed air pressure and operating distance

- Keep the compressed air pressure at a moderate strength only. Pressure at the nozzle should be less than 100 kPa.
- Operating distance from the camera should be 5 to 30 cm.

# Firmware update



This chapter includes instructions on updating the firmware on your Allied Vision Bonito PRO camera.



If new firmware contains a new feature or control, saved camera user sets are invalidated and erased!

Before loading new firmware, backup your current camera settings in the frame grabber SDK.



#### NOTICE

Do not unplug the CoaXPress cables or camera power supply during the update procedure. We recommend using auxiliary power instead of PoCXP for firmware updates.



Allied Vision does not provide a firmware loader tool, you should perform firmware updates via the frame grabber SDK.

## Firmware upgrade overview

1. Get remote port and device node map
2. Collect features for file access
3. Firmware upload via FileAccess
  - a. Open the device with your frame grabber SDK
  - b. Open the firmware file and load it into an `std::vector`
  - c. Open the firmware camera file
  - d. Write the firmware data to the camera
  - e. Close camera file
  - f. Reboot the camera

# Get remote port and device node map

## Active Silicon frame grabber code snippet example

```
// Producer and Device handle can be taken from sample application provided by the SDK
CTLProducer *          m_Producer;
GC::DEV_HANDLE        m_Device;

GC::PORT_HANDLE       m_RemotePortHandle;
std::shared_ptr<CPort> m_RemotePort;
std::shared_ptr<CNodeMapRef> m_RemoteDeviceMap;

m_Producer->DevGetPort(m_Device, &m_RemotePortHandle);
m_RemotePort = std::make_shared<CPort>(m_RemotePortHandle, m_Producer);
m_RemoteDeviceMap = m_RemotePort->GetNodeMap();
```

*Code listing 1: Active Silicon code snippet example*

# Collect features for FileAccess

## Active Silicon frame grabber code snippet example

```
CRegisterPtr          m_FileAccessBuffer;
CEnumerationPtr       m_FileSelector;
CEnumerationPtr       m_FileOpenMode;
CEnumerationPtr       m_FileOperationSelector;
CIntegerPtr           m_FileAccessLength;
CCommandPtr           m_FileOperationExecute;
CIntegerPtr           m_FileOperationResult;
CEnumerationPtr       m_FileOperationStatus;
CEnumerationPtr       m_FileStatus;

m_FileAccessBuffer    = m_RemoteDeviceMap->_GetNode("FileAccessBuffer");
m_FileSelector        = m_RemoteDeviceMap->_GetNode("FileSelector");
m_FileOpenMode        = m_RemoteDeviceMap->_GetNode("FileOpenMode");
m_FileOperationSelector = m_RemoteDeviceMap->_GetNode("FileOperationSelector");
m_FileAccessLength    = m_RemoteDeviceMap->_GetNode("FileAccessLength");
m_FileOperationExecute = m_RemoteDeviceMap->_GetNode("FileOperationExecute");
m_FileOperationResult = m_RemoteDeviceMap->_GetNode("FileOperationResult");
m_FileOperationStatus = m_RemoteDeviceMap->_GetNode("FileOperationStatus");
m_FileStatus          = m_RemoteDeviceMap->_GetNode("FileStatus");
```

*Code listing 2: Active Silicon code snippet example*



# Firmware upload via FileAccess

Step 1: Open the device with your frame grabber SDK

Step 2: Open the firmware file and load it into an std::vector

Step 3: Open the firmware camera file

## Euresys frame grabber code snippet example

```
template <typename T>
static bool OpenCameraFile(EGrabber<T> &frameGrabber, const std::string &fileName)
{
    // basically fopen( fileName, "w")
    frameGrabber.setString<RemoteModule>("FileSelector", fileName);
    if( frameGrabber.getString<RemoteModule>("FileStatus") != "Closed")
    {
        CloseCameraFile(frameGrabber, fileName );
    }
    frameGrabber.setString<RemoteModule>("FileOperationSelector", "Open");
    frameGrabber.setString<RemoteModule>("FileOpenMode", "Write");
    frameGrabber.execute<RemoteModule>("FileOperationExecute");
    if( frameGrabber.getString<RemoteModule>("FileOperationStatus") == "Success"
        && frameGrabber.getString<RemoteModule>("FileStatus") == "Open")
    {
        return true;
    }
    return false;
}
```

Code listing 3: Euresys code snippet example

## Active Silicon frame grabber code snippet example

```
void open(const std::string& fileName, OpenMode mode)
{
    if( FileStatus() != "Closed")
    {
        close( fileName );
    }
    m_FileSelector->FromString( fileName.c_str() );
    m_FileOperationSelector->FromString("Open");
    m_FileOpenMode->FromString( toString(mode) );
    m_FileOperationExecute->Execute();
    if( FileStatus() != "Open")
    {
        throw RUNTIME_EXCEPTION( fileName + " could not be opened");
    }
}
```

Code listing 4: Active Silicon code snippet example

Step 4: Write the firmware data to the camera

### Euresys frame grabber code snippet example

```
enum CameraRegister
{
    FileAccessBufferReg = 0x25200,
};

template <typename T>
static bool WriteCameraFile( EGrabber<T> & frameGrabber, const std::vector<char> &data )
{
    std::cout<<"\n";
    const int64_t dataToWrite = static_cast<int64_t>(data.size());
    int64_t maxWriteSize = frameGrabber.getInteger<RemoteModule>("FileAccessLength.Max");
    std::vector<char>::const_iterator dataPos = data.begin();
    frameGrabber.setString<RemoteModule>("FileOperationSelector", "Write");
    int64_t bytesWritten = 0;
    while (dataPos < data.end())
    {
        int writeSize = std::min( maxWriteSize, dataToWrite-bytesWritten);
        frameGrabber.gcWritePortData<RemoteModule>(FileAccessBufferReg,&*dataPos, writeSize);
        frameGrabber.setInteger<RemoteModule>("FileAccessLength",writeSize);
        frameGrabber.execute<RemoteModule>("FileOperationExecute");
        if(      frameGrabber.getInteger<RemoteModule>("FileOperationResult") != writeSize
            ||  frameGrabber.getString<RemoteModule>("FileOperationStatus") != "Success" )
        {
            return false;
        }
        double percentWritten = (100.0* bytesWritten )/ dataToWrite;
        std::cout<<"\r"<<std::fixed<<std::setprecision(2)<<percentWritten<<" %    ";
        bytesWritten +=writeSize;
        dataPos +=writeSize;
    }
    return true;
}
```

Code listing 5: Euresys code snippet example

### Active Silicon frame grabber code snippet example

```

void write( const data_vector &data ) const
{
    std::cout<<"\n";
    const size_t maxWrite = static_cast<size_t>(m_FileAccessLength->GetMax());
    data_vector::const_iterator pos = data.begin();
    size_t sizeData = data.size();
    m_FileOperationSelector->FromString("Write");
    while( pos != data.end() )
    {
        int64_t sizeToWrite = static_cast<int64_t>( std::min( maxWrite,sizeData) );

        m_FileAccessLength->SetValue( sizeToWrite );
        m_FileAccessBuffer->Set(&*pos, sizeToWrite);
        m_FileOperationExecute->Execute();

        pos += sizeToWrite;
        sizeData -=sizeToWrite;
        double percent = 100.0- (sizeData*100.0)/data.size();

        std::cout<<std::fixed<<std::setprecision(2)<<"\r"<<percent<<"%
        ";
    }
    std::cout<<"\n";
}

```

Code listing 6: Active Silicon code snippet example

Step 5: Close camera file

### Euresys frame grabber code snippet example

```

template <typename T>
static bool CloseCameraFile(EGrabber<T> &frameGrabber, const std::string &fileName)
{
    // basically fopen( fileName,"w")
    frameGrabber.setString<RemoteModule>("FileSelector", fileName);
    frameGrabber.setString<RemoteModule>("FileOperationSelector", "Close");
    frameGrabber.execute<RemoteModule>("FileOperationExecute");
    if (frameGrabber.getString<RemoteModule>("FileOperationStatus") == "Success"
        && frameGrabber.getString<RemoteModule>("FileStatus") == "Closed")
    {
        return true;
    }
    return false;
}

```

Code listing 7: Euresys code snippet example

### Active Silicon frame grabber code snippet example

```
void close( const std::string & fileName )
{
    m_FileSelector->FromString( fileName.c_str() );
    m_FileOperationSelector->FromString("Close");
    m_FileOperationExecute->Execute();
    if( FileStatus() != "Closed")
    {
        throw RUNTIME_EXCEPTION(fileName + " could not be closed");
    }
}
```

*Code listing 8: Active Silicon code snippet example*

Step 6: Reboot the camera

You must always power cycle the camera after a firmware upgrade or downgrade.

# Index

## A

Adjustment  
 F-Mount .....69

## C

Camera GND ..... 80, 82  
 Camera power ..... 78, 80  
 Cleaning  
   Compressed air .....93  
   Instructions .....92  
   Locating impurities.....91  
   Materials .....91  
 CoaXPress interface .....76

## D

Document history .....21

## E

EF lens control .....84  
 electrostatic discharge.....23  
 Environmental specifications.....31  
 ESD..... 23, 31

## F

Flange focal distance  
 F-Mount ..... 66, 67, 68, 69  
 Frame rate .....46  
   CCD sensors .....46

## G

GenICam .....45  
 GND  
   Camera .....78

## H

heat dissipation..... 29

## I

In 1 ..... 78, 80  
 In 2 ..... 79, 81  
 Interline boundary ..... 86  
 IR filter ..... 72  
 Isolated In GND ..... 78, 81  
 Isolated Out Power ..... 78, 82, 83

## L

lenses  
   maximum protrusion..... 32

## M

Manual conventions  
   Styles ..... 22  
   Symbols ..... 22

## O

Out 1 ..... 78, 82  
 Out 2 ..... 79, 82  
 Out 3 ..... 78, 82, 83  
 Out 4 ..... 78, 82, 83

## P

Power  
   DC..... 40

## R

Resolution and ROI frame rates  
   Model comparison ..... 57

RS232 .....78

## S

safety .....2, 4, 13, 22, 29

    camera power .....31

    electrical connections .....31

    heat dissipation .....29

    lens mounts.....29

    maximum protrusion .....32

    optical components .....32

    sensor.....32

sensor handling .....32

Sensor position accuracy .....71

### Signal

    Exposing .....86

    Exposure cycle.....86

    Exposure start delay.....86

    Idle .....86

    Imaging.....86

    Integrating light.....82

    Interline time .....86

    Registered exposure time .....86

    Sensor row readout cycles ..... 86

Specifications ..... 44

Status LEDs..... 75

## T

### Trigger

    Exposure ..... 85

    Integrating light ..... 85

    Latency time ..... 85

    Logic trigger..... 85

    Propagation delay ..... 85

    Readout ..... 85

    Readout data ..... 85

    Rules ..... 86

    Time delay ..... 85

    Timing diagram..... 85

    Tpd ..... 85

    Trigger jitter ..... 85

    Trigger latency..... 85

    Trigger ready ..... 86

    User trigger ..... 85

Tripod adapter ..... 66