

Uniblitz® LS3

3mm Uni-Stable Laser Shutter



Overview

The Uniblitz LS3 is a high-performance laser shutter, ideal for precision exposure control, laser switching, and other applications that benefit from the precise, repeatable characteristics of the LS shutter series. These include low level laser chopping, and pulse gating, selection, and modulation to 200Hz.

Uni-stable shutter devices, like the LS3, require power to hold the blades in the open state (though the device can be custom-configured for "normally open" operation).

Need Support? Please [visit our website](#) or email us at info@uniblitz.com.

Tel: 585-385-5930 | Toll-Free: 800-828-6972 | Fax: 585-385-6004 | 803 Linden Ave. Rochester, NY 14625
Updated 7/19 | Datasheet Version 5.4 | ©2019 Vincent Associates

Key Features

- 3mm aperture, Uni-Stable
- **510A** cable included
- Laser Energy Rating:
5 W/mm² (with "ZM" blades)
- **RoHS Compliant**
- Transfer time on opening:
0.5 milliseconds
- Total opening time:
1.5 milliseconds
- Configured for the **VCM-D1 Shutter Driver**

Product Options

LS3 2 3 4 5 6 - 7 - 8

Ex: LS3S2ZM0-EC-21

1 Shutter Series:

- **LS3**

2 Driver Compatibility:

- **S:** Use with VCM-D1 (Std.)
- **E:** Use with D880C or VED24

3 Housing:

- **1:** Un-Housed
- **2:** #2 Housing

4 Blade Coating: ¹

- **T:** Low Energy (Teflon[®])
- **ZM:** High Energy (AlMgF₂) ²
- **Z:** High Energy (AlSiO) ²

5 Electronic Sync:

- **0:** Omitted
- **1:** Included

6 Encapsulated Coil:

- **EC:** Included
- Leave blank if not required

7 Mount:

- **21:** Zeiss Axiovert
- **24:** Olympus BX/IX
- **27:** Nikon
- **100:** Mounting Ring
- **105:** C-Mount (Male)
- **106:** C-Mount (Female)
- Leave blank if not required

¹ Other blade coating options may be available by special order.

² Input side only; Teflon[®] coating is on opposite side to protect shutter blade surface. Light source must be input to the reflective side only.

Shutter Timing

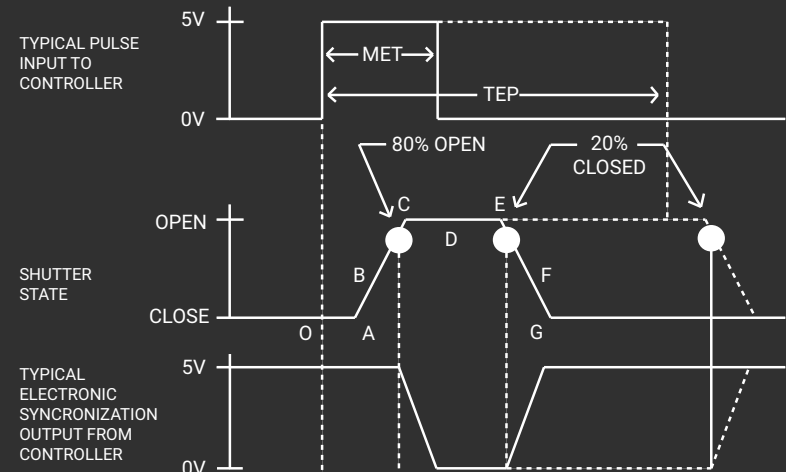

LS3 (w/ VCM-D1 driver and Teflon[®] coated blades) Time (msec.)

Transition	Description	Time (msec.)
O - A	Delay time on opening after current applied	1.0
A - C	Transfer time on opening	0.5
O - C	Total opening time	1.5
C - E	Min. dwell time with min. input pulse	0.8
B - F	Min. equivalent exp. time	1.5
E - G	Transfer time on closing	0.6
A - G	Total window time	1.9
MET	Min. exposure time	2.0
TEP	Typical exposure pulse	>2.3

Technical Specifications

Coil Resistance	Voltage to Open	Hold Voltage (Nominal) ¹
48 Ω	+65 VDC	+10 VDC

¹ Voltage level required across actuator coil when being held in the open position.

² (Continuous/Burst) Continuous frequency rating specified at shutter's minimum exposure pulse. Burst frequency rating specified for four (4) seconds maximum with one (1) minute minimum between bursts.

Series	Weight (Housed)	Operating Temp.	Max. Opening Bounce	Max. Closing Bounce	Max. Freq. of Operation ²	Number of Shutter Blades
LS3	7.41 oz (0.21 kg)	0 - 80 °C	15%	5%	50 Hz / 200 Hz	2

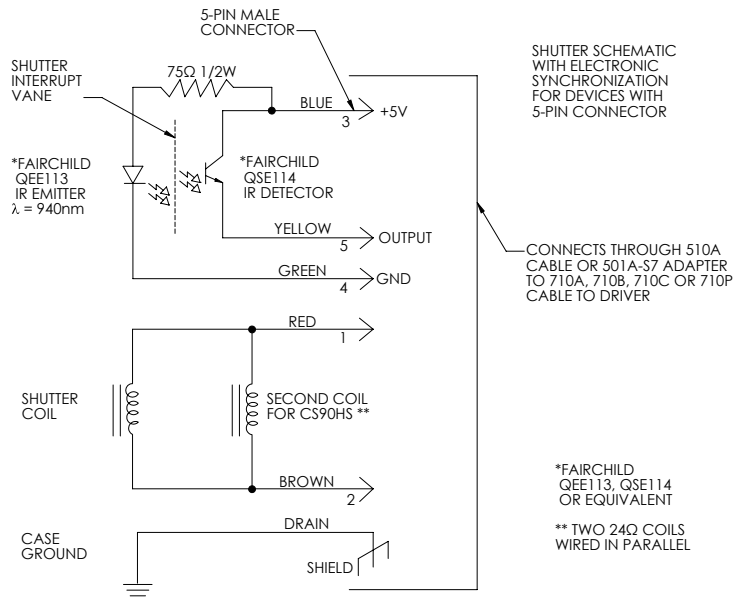

The electronic synchronization system provides a feedback signal (through the driver utilized) after the shutter transfers to the open state. The system incorporates an infrared emitting diode, an infrared sensitive detecting transistor, and an interrupting vane. The vane is attached to the shutter so as to block the light path between the emitter and detector in the closed position. When the shutter transfers to the 80% open position, the vane is removed from the infrared light path, allowing the emitter to switch the detector to the active state. For the LS3, this system uses a similar activation flag attached to the mechanism, which triggers a reflective emitter/detector device. **No connection to the designated synchronization pins when no electronic sync. is selected.**

Technical Drawings - Un-housed LS3

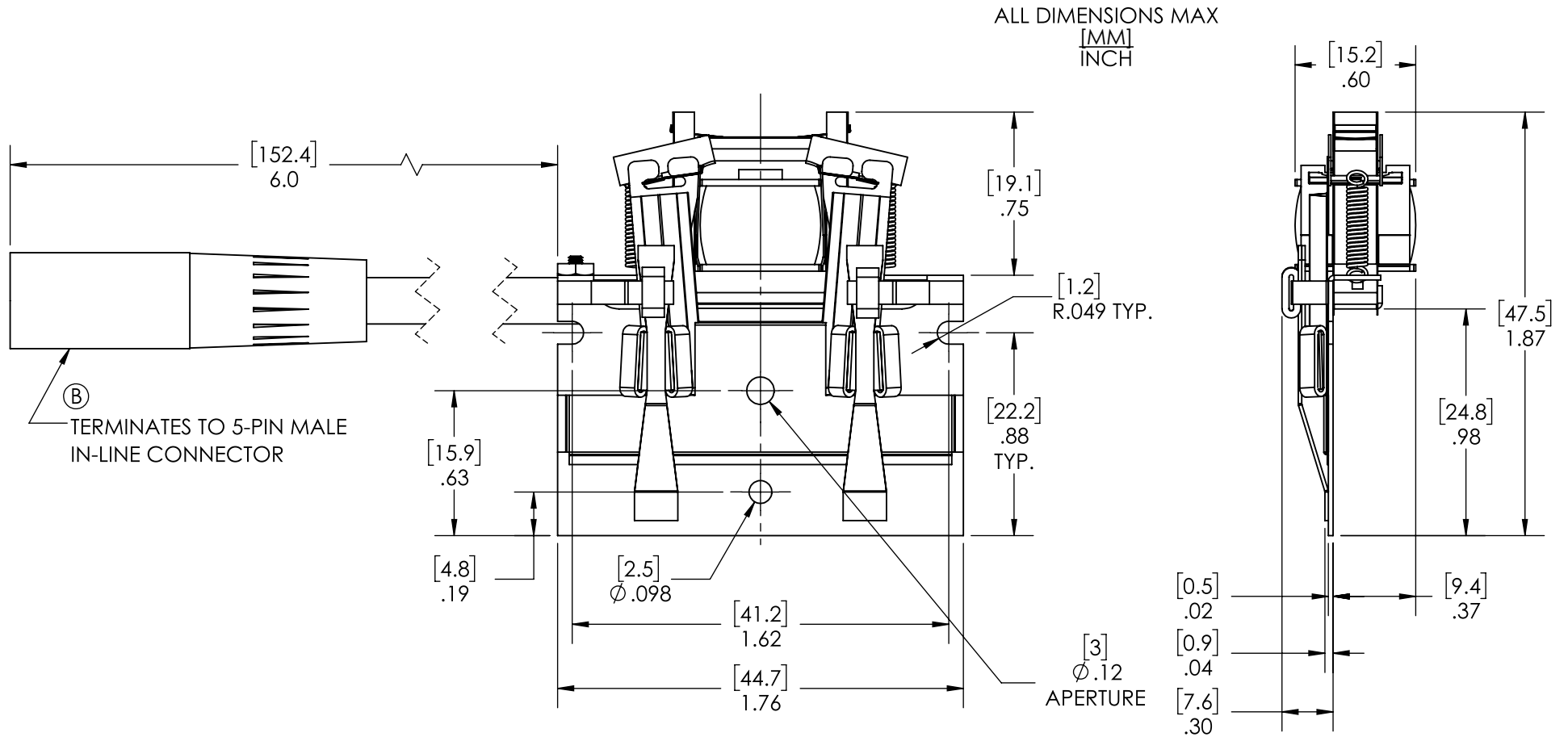

Technical Drawings - LS3 Housing/Connector Layout

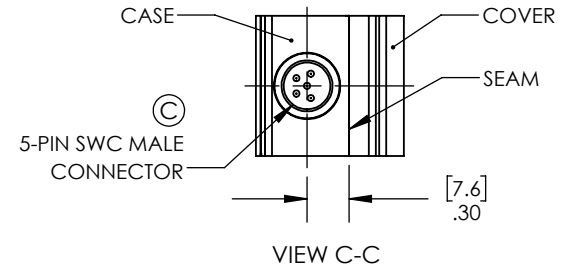
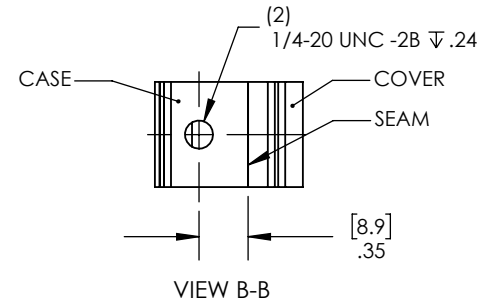
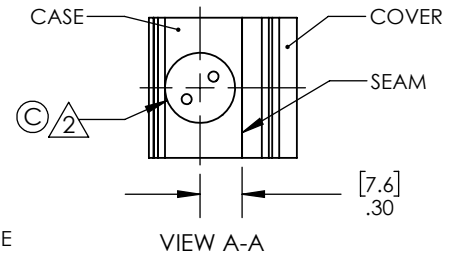
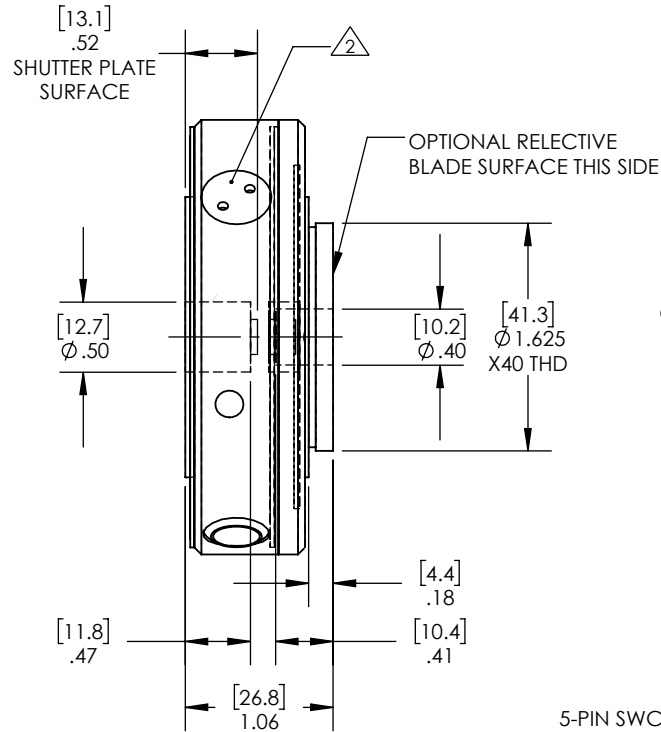
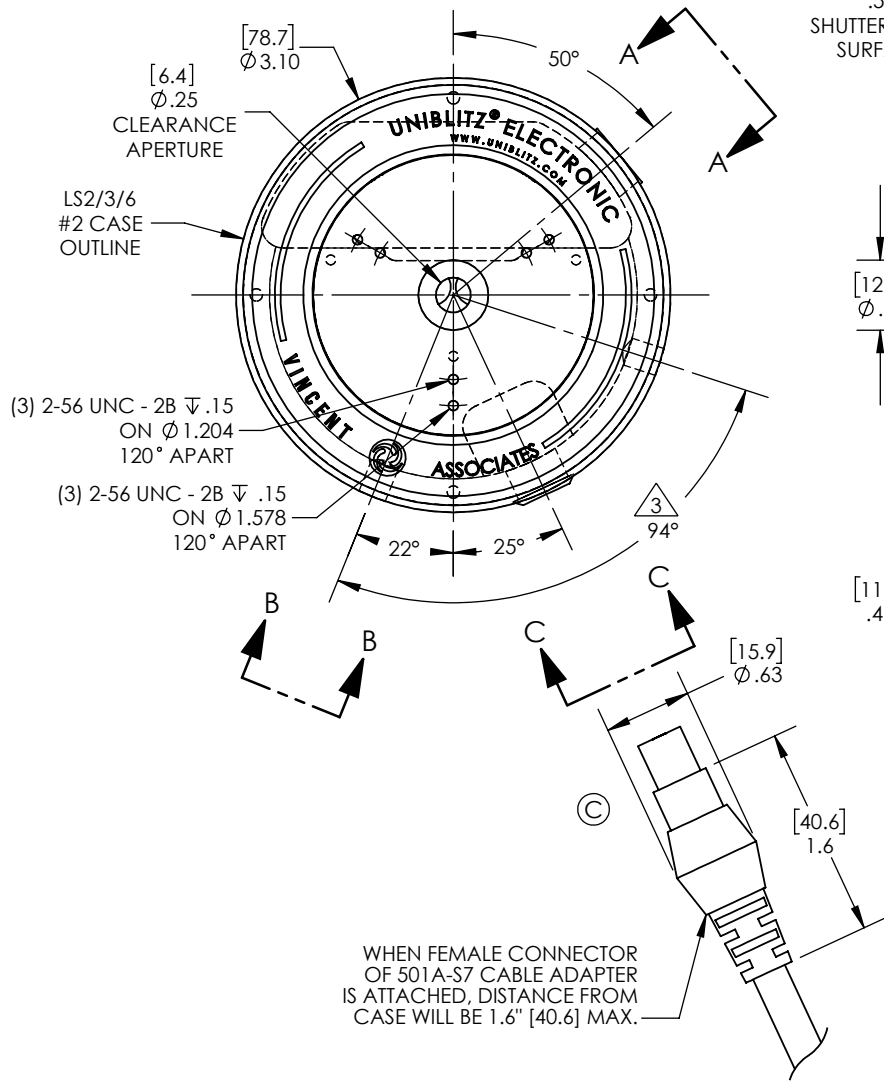

Technical Drawings - 510A (Included)

